

Critical Service

Flanged Safety Relief Valves
Series 447
Series 546



CATALOG

LESER

The-Safety-Valve.com

LESER safety valves for every industrial application

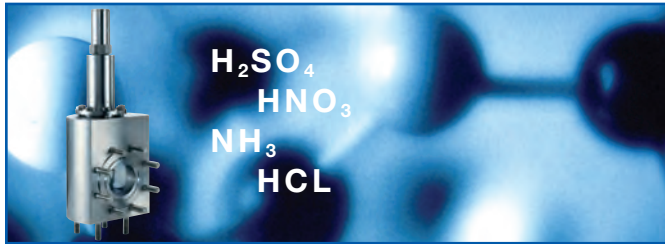

Critical Service

Series 447

Type 447

Type 449

High Performance



Compact Performance



API



Clean Service



Modulate Action



Best Availability

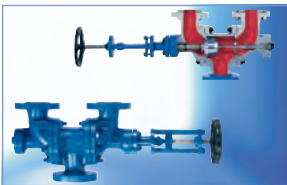

Series 546

Type 546

Type 5466



General Information



Type 447

DN 25 – DN 100, 1" – 4"
Set pressure 0,1 – 16 bar, 1,5 – 232 psig

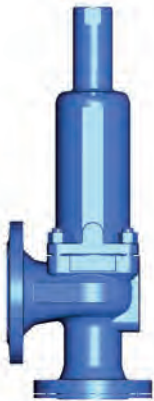

Type 546

DN 25 – DN 100, 1" – 4"
Set pressure 0,5 – 10 bar, 7,2 – 145 psig

Type 5466

DN 25 + DN 50, 1" + 2"
Set pressure 0,5 – 10 bar, 7,2 – 145 psig



Type 449

DN 25 – DN 100, 1" – 4"
Set pressure 0,1 – 16 bar, 1,5 – 232 psig

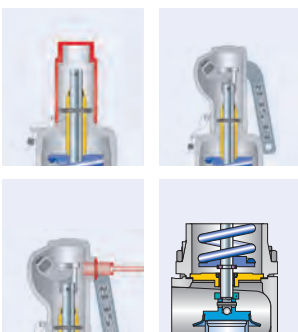

Accessories and Options

Overview **Page**

General information	
Applications, General design features	6
Valve finder	7
Valve finder and Level-Concept	8
Lining materials	
• PTFE materials	10
• Comparison PTFE / PFA	11
• Comparison of Critical Service – API	14
Configuration features	
• Design features – Type 447	12
• Isostatical manufacturing process	13
How to use	
Characters and symbols	15
Flange drillings and facings	15
Sample Capacity table	16
LESER Effective Orifice $S_{G/L}$	18
How to use	
Determination of coefficient of discharge K_{dr}/α_w	20

LESER Type **Page**

Type 447	
Materials	
• Conventional design – Level 3	20
• Chlorine application – Level 3	22
How to order	
• Numbering system	26
Article numbers	28
Dimensions and weights	
• Metric and US units	29
Pressure temperature ratings	
• Metric und US units	30
Order information	
• Flange drillings	31
• Spare parts	31
Available options	32
Approvals	33
Capacities – Metric units	
• Steam, Air, Water	34
Capacities – US units	
• Steam, Air, Water	35
Determination of coefficient of discharge K_{dr}/α_w	36

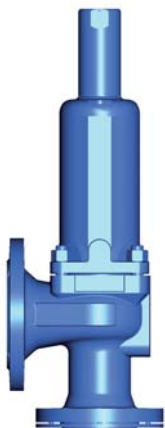

Type 546
Cap H2
Closed bonnet
Conventional design



Type 546
Packed lever H4
Closed bonnet
Balanced bellows design



Type 5466
Cap H2
Closed bonnet
PTFE bellows design

LESER Type	Page
Type 546, 5466	37
Materials – Type 546	
• Conventional design – Level 1	38
• Balanced bellows design – Level 1	40
Materials – Type 5466	
• PTFE bellows design – Level 2	42
Article numbers	44
Dimensions and weights	
• Metric units	46
Pressure temperature ratings	
• Metric units	47
Order information	
• Flange drillings	48
• Spare parts	49
Available options	50
Approvals	51
Capacities – Type 546 – Metric units	
• Steam, Air, Water	52
Capacities – Type 5466 – Metric units	
• Steam, Air, Water	53
Determination of coefficient of discharge K_{dr}/α_w	54

LESER Type	Page
Type 449	55
Application range	56
Protective gas flushing design	56
Article numbers	57
Dimensions and weights	
• Metric units	58
How to order	
• Specification sheet	59
Options	61
Overview	62
Caps and levers	64
Bellows design	66
Sealing plate	68
Lift indicator	69
Lift restriction	70
FAQ	71



Type 447
 Packed lever H4
 Closed bonnet
 Conventional design



Type 449
 Packed lever H4
 Closed bonnet
 Conventional design



Type 449
 Cap H2
 Closed bonnet
 Balanced bellows design

LESER – Critical Service Safety Valves

The Critical Service product group represents

- ✓ Standardised solutions for special applications such as those involving critical and toxic media
- ✓ Optimal and permanent corrosion protection for chemical applications
- ✓ Technologically-sound and inexpensive alternative to nickel-based alloys (such as Hastelloy®)

The protection of valves against corrosion has a significant impact on the total cost of ownership (TCO) and plays a key role in system safety. Polytetrafluorethylene (PTFE) is a high-performance plastic which has become widely accepted in the chemical industry due to its unique properties.

LESER Critical Service Safety Valves ...

... combine safety valve know-how with a level-based PTFE equipment and lining concept.

All components of Critical Service safety valves are made with PTFE-lined materials, including the permanently medium wetted inlet area composed of a nozzle and a disc, the additional protection of the bonnet area by means of a bellows and all components of the inlet and outlet areas.

- Designed and manufactured according to the highest standards
- Reach their full lift within a pressure increase of 10% above the set pressure
- Are characterised by longstanding proof in service.
- Are developed and optimised in close cooperation with plant engineers and service specialists to protect processes with highly corrosive and toxic media.
- Meet the highest requirements of end customers, OEMs and planners.
- Are approved by all important classification societies worldwide. This ensures the worldwide applicability of LESER Critical Service safety valves.
- Designed in accordance with numerous regulations, labelled, produced and approved in accordance with:
 - CE marking** in accordance with Pressure Equipment Directives 97/23/EC and DIN EN ISO 4126-1
 - UV stamp** as per ASME Section VIII Division 1
 - VdTÜV approval** as per the Pressure Equipment Directive, EN ISO 4126-1, TÜV SV 100 and AD 2000-Merkblatt A2
 - AQSIQ** based on the approvals acc. to AD 2000-Merkblatt A2
 - Eurasian Custom Union:** as per EAC - Eurasian Conformity

Applications

LESER – Critical Service Safety Valves

provide solutions for protection against highly corrosive and toxic media in all industrial applications with vapours, gases and fluids.

Lined LESER safety valves are used primarily in chemical, pharmaceutical, petrochemical and industrial process engineering.

Typical applications for LESER Critical Service safety valves are:

- Chlorine production and processing
- Chemical systems and pipelines
- Reducing media such as acids (e.g. hydrochloric acid, acetic acid, etc.)
- Alkaline solutions (like sodium hydroxide applications)
- All intermediate products such as amines, diols and polyalcohol. They are used as raw materials for coatings, plastics, pharmaceuticals, textile fibres, detergents and pesticides, among other things.
- Electronic chemicals and other pure media
- All types of chemicals and media that are classified as being corrosive, highly corrosive, toxic or hazardous

The following circumstances require the use of a Critical Service safety valve:

- if metal-free surfaces are needed, e.g. fluids reactive to metal
- if stainless steel, Hastelloy® etc. is not adequately chemically resistant to the fluids
- if the fluids require the use of exotic metals, which would result in very high investment costs
- if anti-adhesive surfaces are needed

General Design Features

LESER – Critical Service Safety Valves

offer a large variety of types, materials, and options for adaptation to the respective system conditions:





- Valve sizes from DN 25 to DN 100, 1" to 4"
- All media-wetted parts are made with PTFE
- PTFE can also be used in EX areas, due to the antistatic and electrically conductive PTFE compound
- Identical design for steam, gases and fluids (single trim) reduces the number of required spare parts and facilitates cost-effective maintenance
- The one-part spindle reduces friction, guarantees optimal guidance and reliable operation under all operating conditions
- The self-draining body avoids media residue
- Lift indicator for detection of opening operations of the safety valve and forwarding the signal to a control room.
- Each part can be produced in other materials such as Hastelloy® according to customer specifications

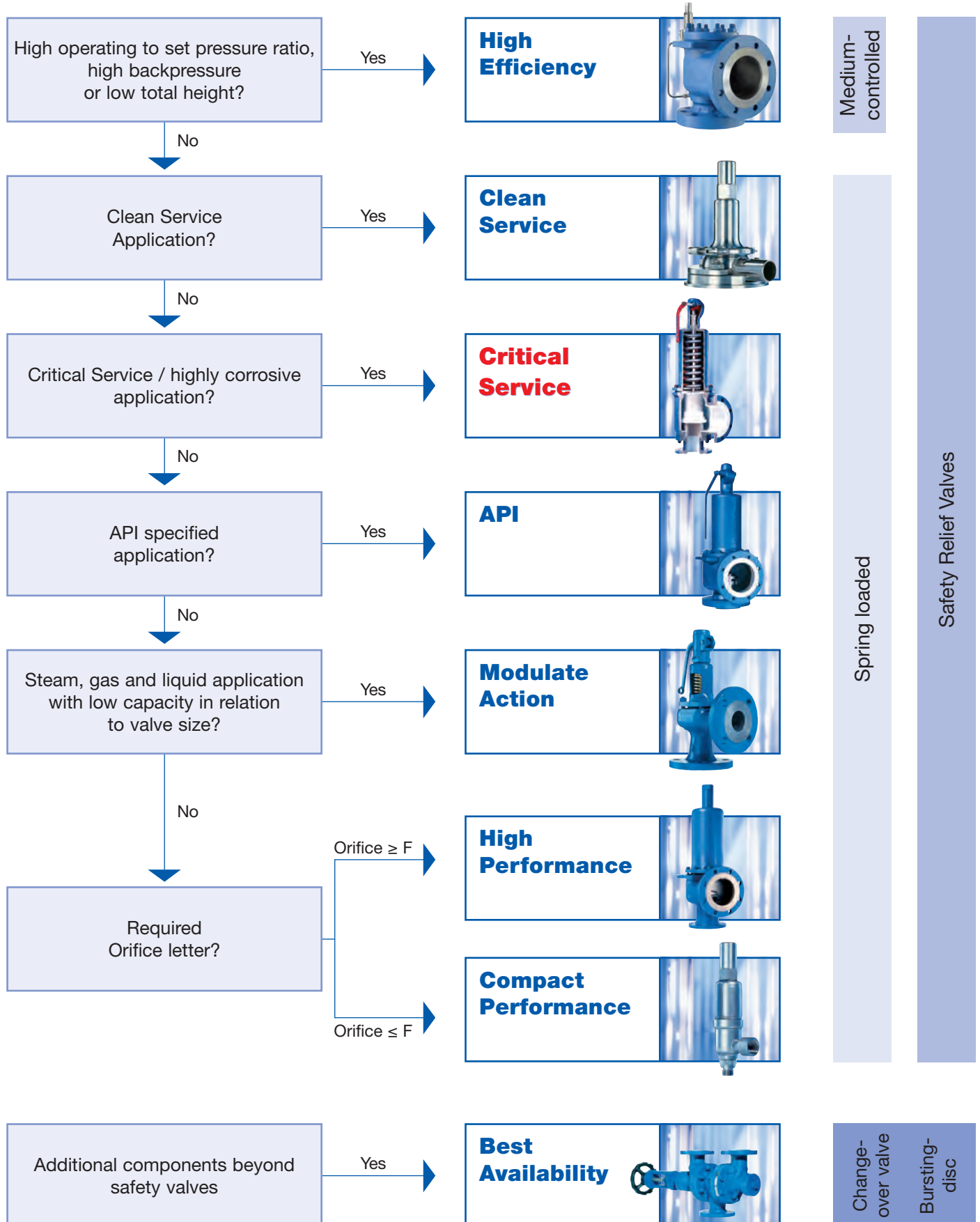

How to find the right product group



How to find the right Critical Service safety valve

Type	Orifice	Level	Corrosion resistance	Description
<p>447</p> 	G - N	3	Inlet ■ ■ ■ Outlet ■ ■ ■ Bonnet space – Standard with PTFE-bellows ■ ■ ■	Type 447 is an economical alternative for applications in which there is also a highly corrosive atmosphere in the outlet body which requires the best protection through a PTFE lining.
<p>5466</p> 	G - K	2	Inlet ■ ■ ■ Outlet ■ ■ ■ Bonnet space – Standard with PTFE-bellows ■ ■ ■	Type 5466 is the solution for applications in which activation of the safety valve rarely occurs and the protective coating together with the bellows provides adequate corrosion protection on the outlet side.
<p>546</p> 	G - N	1	Inlet ■ ■ ■ Outlet ■ ■ ■ Bonnet space – Standard without bellows ■ ■ ■ – Option with balanced bellows ■ ■ ■	Type 546 is the solution for applications in which activation of the safety valve is very unlikely, due to the large difference between the operating and set pressure.
<p>449</p> 	G - N	Customized	Inlet ■ ■ ■ Outlet ■ ■ ■ Bonnet space – Standard with balanced bellows ■ ■ ■	Safety valve with gas flushing system. A second duct system is built around all system components that carry highly toxic media. This second casing is flooded with a carrier gas that neutralises the highly-toxic fluid in the event of a leak. Type 449 can be directly integrated into these carrier gas flushing systems.

How to find the right Critical Service safety valve

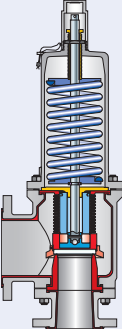
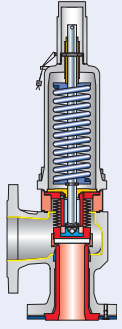
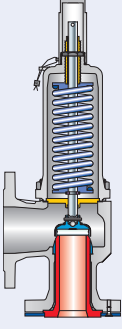
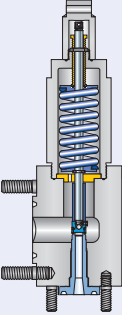
Type	Design features
<p style="text-align: center;">447</p> 	<ul style="list-style-type: none"> • Inlet body and outlet body are lined with virgin PTFE for the utmost corrosion resistance • Nozzles made of gas-tight sintered PTFE-TFM + 25% glass for the prevention of corrosion in the inlet of the body. • Sealing plate made of BOROFLOAT glass for high chemical resistance. A metallic sealing plate support ensures high mechanical stability of the disc unit. Material coupling in PTFE-nozzle – disc with sealing plate made of BOROFLOAT glass for high leak-tightness. • PTFE bellows hermetically seals the bonnet space and protects against soiling and corrosion.
<p style="text-align: center;">5466</p> 	<ul style="list-style-type: none"> • Nozzles made of gas-tight sintered PTFE-carbon compound for the prevention of corrosion in the inlet of the body. Metallic support of the nozzle prevents the PTFE-carbon compound from flowing under pressure. • The sealing plate made of PTFE-carbon compound ensures high chemical resistance. A metallic sealing plate support ensures high mechanical stability of the disc unit. • Additional corrosion protection by coating the blow-off chamber of the body with a conductive two-component coating. • PTFE bellows hermetically seals the bonnet space and protects against soiling and corrosion.
<p style="text-align: center;">546</p> 	<ul style="list-style-type: none"> • Nozzles made of gas-tight sintered PTFE for the prevention of corrosion in the inlet of the body. Metallic support of the nozzle prevents the flowing of the PTFE under pressure. • The bonnet space and the sliding components can be protected against corrosion with a stainless steel bellows. • Sealing plate made of BOROFLOAT glass for high chemical resistance. A metallic sealing plate support ensures high mechanical stability of the disc unit. • Material coupling PTFE (nozzle) with BOROFLOAT glass (disc sealing plate) ensures a high leak-tightness.
<p style="text-align: center;">449</p> 	<ul style="list-style-type: none"> • A bore system for the absorption of carrier gas flushing. • Bellows for back pressure compensation and for sealing the bonnet space. • Manufacture of the body components as well as most inner components of bar or forged material in order to realise customer-specific material requirements, nominal pressure ratings, drillings, and center to face dimensions.

PTFE materials

Polytetrafluorethylene (PTFE) is a high-performance plastic which is known for its unique properties. Several different types of this universal material are used at LESER.

An overview of the types of materials used:

Virgin PTFE-TF stands for a polytetrafluorethylene thermoplastic that has a linear and partially crystalline structure.

Modified PTFE, type PTFE-TFM™, the 2nd generation, is produced by adding less than 1% PPVE, which changes the molecular structure of virgin PTFE. Due to this structure change, it is given high form stability under strain and better gas-tightness.

For 25% glass-modified PTFE TFM™, fibre glass is added to the production process to improve impact and compression strength.

For 25% carbon-modified PTFE TFM™, graphite carbon is added to the production process to achieve a lower volume resistance and also improve impact and compression strength.

The anti-static and electrically conductive PTFE is suitable for use in areas with explosion risk.

Virgin PTFE (TF)	PTFE (PTFE-TFM™), modified PTFE	PTFE-TFM with 25% glass	PTFE-TFM with 25% carbon	PTFE, antistatic and electrically conductive
Component				
Lining Inlet and Outlet	Bellows	Nozzle	Sealing plate	Option
Colour				
white	white	grey-beige	black	black
General properties				
<ul style="list-style-type: none"> • General application temperature range is from -200 °C / -328 °F to +260 °C / +500 °F • Resistant to almost all chemicals • Outstanding anti-friction property, no "stick-slip" effect (build-up), high dimensional precision even under strain • Light and water resistant as well as non-flammable 				
Specific volume resistance Ohm x cm				
$\geq 10^{18}$	$\geq 10^{18}$	$\geq 10^{18}$	$10^3 - 10^4$	$10^3 - 10^4$
Special properties				
	Permeability as per DIN 53380, film thickness 1 mm and chlorine gas at +54 °C: $160 \frac{\text{cm}^3}{\text{m}^2 \times \text{d} \times \text{bar}}$	Low dimensional tolerance and deviations compared to virgin PTFE		Specific volume resistance $< 10^6 \Omega/\text{cm}^{(1)}$ Surface resistance $10^3 \Omega^{(1)}$, no possible electrostatic charging

¹⁾ Materials with a volume resistance $\leq 10^6 \Omega/\text{cm}$ are considered to be electrically conductive.
Materials with a surface resistance $\leq 10^3 \Omega$ are considered to be anti-static.

LESER nozzles, sealing plates, etc., are manufactured exclusively out of compression-moulded, sintered semi-finished products (bars) made of virgin PTFE, modified PTFE with 25% glass, modified PTFE with 25% carbon or electrically conductive pigment compounds.

To decrease permeability, bellows are manufactured exclusively of virginal, compression-moulded and sintered semi-finished products made of PTFE-TFM.

Comparison PTFE / PFA

The following is a comparison of the properties of the widely used PFA and PTFE, which is LESER uses exclusively.

Comparison of the lining materials PTFE / PFA	
PTFE – Isostatic lining [Polytetrafluorethylene]	PFA [Perfluoralkoxy-Copolymere]
Semi-crystalline fluoro-plastic	Semi-crystalline copolymere
Processing in an isostatic compression moulding process followed by a gas-tight sintering process	Processing in melted state – injection mouldable
as a result:	
Process-reliable isostatic lining	High degree of shrinkage due to process, therefore low vacuum fastness
High diffusion resistance with highly permeating liquids	Susceptible to fatigue cracks
Thinner wall thicknesses adequate compared to PFA	High degree of shrinkage cavity formation from manufacturing process
Very good ageing resistance	Higher water absorption compared to isostatic PTFE
Low water absorption	Permeability greater than with isostatic PTFE
Good vacuum seal	Greater wall thicknesses required
No fatigue cracks	Higher material and lining costs
No susceptibility to stress cracking	Greater susceptibility to stress cracks

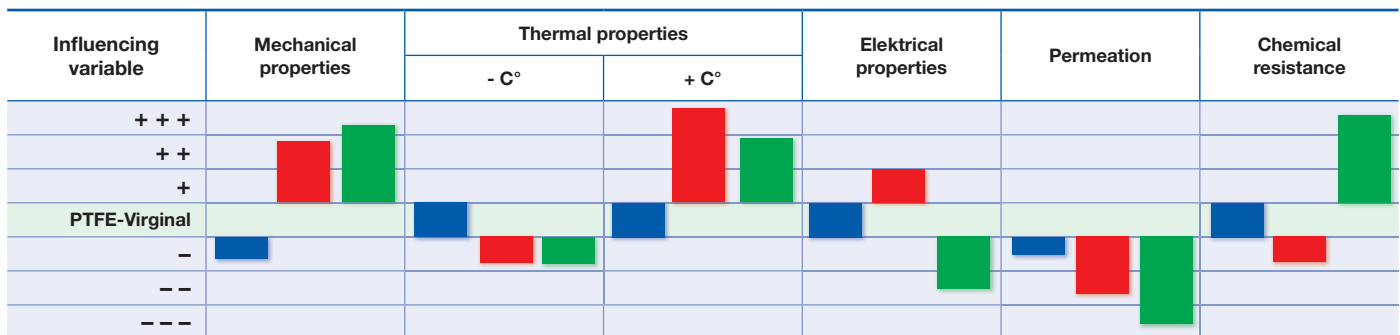

Materials:

- PFA
- PTFE-carbon
- PTFE-glass

Design features – Type 447

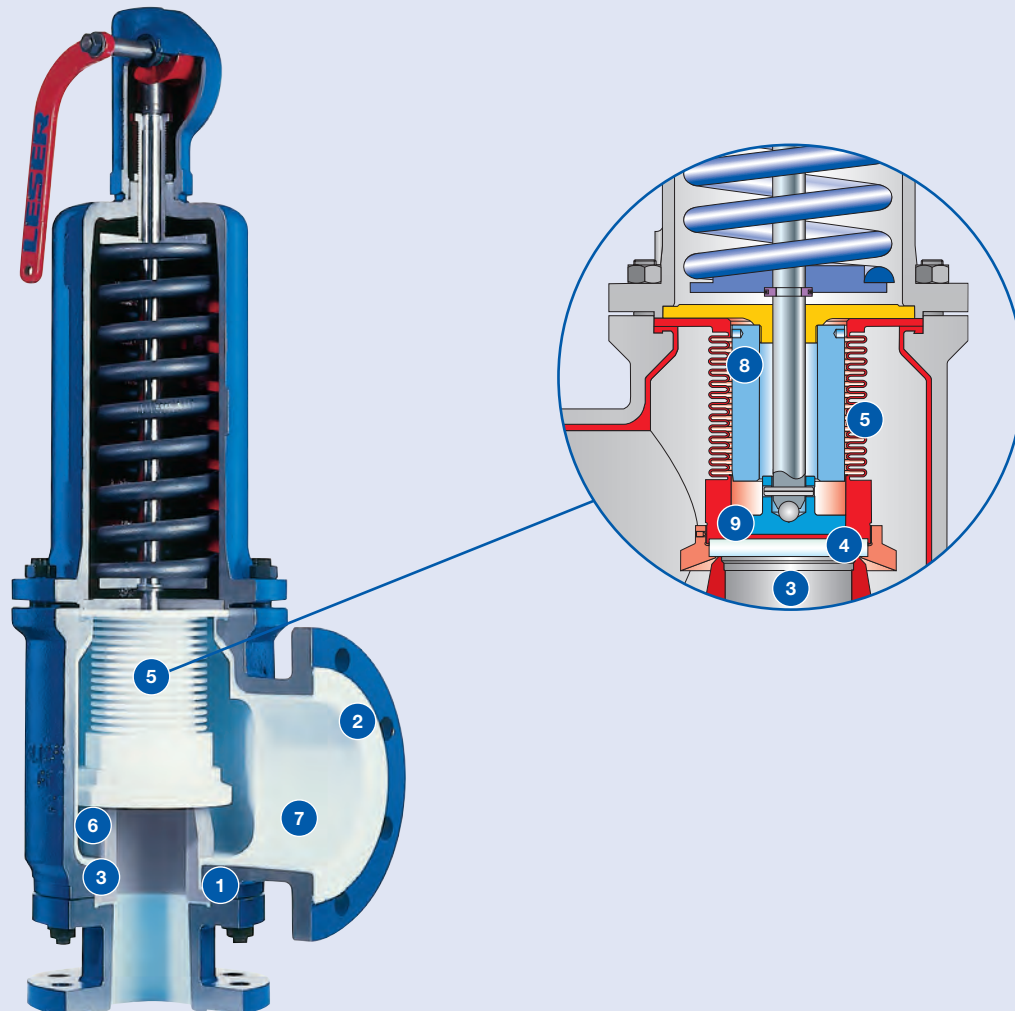

Design features

Item	Component	Information
1	Inlet body + outlet body	Inlet body of material 1.0460 (SA 105) and outlet body of material 1.0619 (WCB) with PTFE lining for highest corrosion resistance
2	PTFE lining	Vacuum-proof, isostatic full lining of the body components of virgin PTFE with a minimum thickness of ≥ 3 mm. All lined surfaces are mechanically processed and have a smooth surface ($R_a = 1,6 \mu\text{m}$). This prevents build-ups of the medium
3	Nozzle	Nozzle of high-quality, inert gas sintered PTFE with 25% glass for high strength
4	Sealing plate	Sealing plate of BOROFLOAT glass for maximum chemical resistance
5	PTFE bellows	PTFE-TFM bellows protect the bonnet space against corrosive and aggressive media
6	Inlet body, nozzle and sealing plate	To fulfil individual material requests, the following components are exchangeable: inlet body (Item 1), nozzle (Item 5), and sealing plate (Item 7.3)
7	Outlet body	Self-emptying outlet body prevents collection of the medium in the blow-off chamber
8	Bellows support	Interior bellows support reduces flow loads resulting in a longer service life
9	Disc insert	Completely metallic support of the sealing plate with disc insert of 1.4404 (316L)

Isostatic pressing method

Linings made of isostatic PTFE have successfully proven themselves everywhere where extremely aggressive media is processed. The PTFE lining for cast or metal bodies is produced using following the isostatic compression moulding process.

Type 447 casing components are fully lined with high-quality virgin PTFE-TF, exclusively using the reliable isostatic process. Compared to other lining processes like injection moulding methods, the process reliability of the isostatic process guarantees to avoid lining flaws like stress cracks, pores, blow-holes, internal flaws due to varying shrinkage and internal stress.

Due to the isostatic manufacturing method, lined parts have an outstanding vacuum seal with low permeability, even with small wall thicknesses. The level of quality is checked by the high-voltage breakdown test as per DIN 28055-T2.

PTFE-lined bodies are manufactured in three main production steps:

- Preparation for lining
- Lining by a sintering process
- Final machining

Main production steps		Information
Preparation for lining		
		Machining of the body surfaces that will be lined / coated. Roughening the surfaces by subsequent sand blasting.
Lining with a sintering process		
		Press moulds are placed over the surfaces to be lined and filled with powdery PTFE.
		The body is put under pressure of > 500 bar acts on all directions in a pressure vessel. This strongly compacts the PTFE powder and presses it onto the roughened surface of the metal. This results in a form-fitted and force-fitted connection between the PTFE and the metal. Afterwards, the casing is sintered, through which the lining obtains the strength and low permeability.
Final machining		
		Machining of all surfaces
		The minimum PTFE wall thickness is $\geq 3 \text{ mm}$ ($\geq 1/8 \text{ inch}$).

Comparison of Critical Service – API



PTFE-lined Critical Service Safety Valves compared with API 526 High Alloy Safety Valves

Critical Service safety valves, particularly Type 447, are a technologically-sound and inexpensive alternative to conventional safety valves that are completely or partially made of nickel-based materials.

An outstanding property of PTFE is its excellent and broad chemical resistance, which ensures protection against corrosion.

The age-resistance of the material and its resistance to embrittlement have a positive effect on life cycle costs.

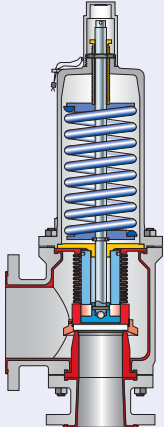
Nickel-based alloys are used in LESER's Type 526. The "LESER level concept", which enables the configuration of different levels of corrosion protection, is available in the API series with nickel-based alloys.

	Critical Service Type 447	API Type 526 High Alloy
Design		
Inlet is resistant to corrosive media	✓	✓
Outlet is resistant to corrosive media	✓*	✓
Set pressure < 16 bar	✓	✓
Set pressure > 16 bar	-	✓
Temperature < 200°C	✓	✓
Temperature > 200°C	-	✓
Construction and design as with API 526	(✓)**	✓

* Available for less and with quick delivery for Type 447.

** Nominal sizes and centre to face dimensions are largely identical to API 526.

General signs and symbols		Signs and symbols for flange drillings and flange facings	
<input type="checkbox"/> *	Standard	<input type="checkbox"/> *	Standard construction, specification of an option code not necessary
<input type="checkbox"/> ✓	Available	<input type="checkbox"/> (*)	Flange dimensions with exception of flange thickness as per flange standards (e.g. ASME B16.5) Flange thickness is less (max. 2 mm), see "Hole patterns valid for different pressure ratings"
<input type="checkbox"/> -	Not possible	<input type="checkbox"/> -	Flange hole pattern / sealing surface not possible

Option code for flange drillings and dimensions, e.g. H50

H50	Flange drilling as specified in flange standard. Outer flange diameter, flange thickness, and height of flange facing may be larger, see "Dimensions".
(H50)	Flange dimensions except flange thickness are in accordance with standards (e.g. ASME B16.5). Flange thickness is smaller (max. 2 mm), see "Multiple pressure rating".
Stock Finish	Flange drilling as specified in standard. Flange thickness may be less than the flange outer diameter as specified in the standard, however complete nut support area is available.

Option code for flange sealing surfaces, e.g. L36

L36	Flange facing as specified in standard.
------------	-----------------------------------------

General information concerning flange drillings and flange facings

Multiple pressure rating	The flange standard shows the same drilling, facing and outer diameter for several pressure ratings, e.g. from PN 16 to PN 40. Due to the pressure rating of the body, LESER fulfills the requirements for flange thickness, e.g. PN 16 but not PN 40.
Smooth Finish	In the applicable MSS SP-6 (Edition 2001), "Smooth Finish" is no longer mentioned. In MSS SP-6 (Edition 1980), "Smooth Finish" was defined as the surface quality of the flange with "250 μinch (6.3 μm) AARH max.". LESER supplies flange sealing surfaces according to ASME B16.5 - 1996, Paragraph 6.4.4.3: "Either a serrated concentric or serrated spiral finish resulting in service finish from 125 to 250 μinch average roughness shall be furnished". This finish meets the requirements of MSS SP-6 (Edition 1980), which is not valid anymore!
Stock Finish	"Stock Finish" is not defined in any technical standard. If "Stock Finish" is specified in the order, then LESER delivers standard flange sealing surfaces as per DIN or ASME (marked with * in the "Flange sealing surfaces" table for each series).

Pressures – Symbols in use

Symbols	Name	Metric units
p	Set pressure	bar
p ₀	Absolute pressure in vessel	
	= p · 1,1 + 1,013	bar _a
	= p · 1,1 + 14,5	psi _a
	The overpressure is 10% of the set pressure, but at least 0,2 bar	
p _a	Back pressure	bar
p _{a0}	Absolute back pressure	
	(= p _a + 1,013)	bar _a
	(= p _a + 14,5)	psi _a

Materials

In the table below, you will find a list of the LESER material codes. Please take into consideration that:

- Material quality certificate 3.1 as per EN 10204 is available for each body material.
- Material quality certificate 3.1, which certifies different materials, is available for many materials.

Material code	Valve body with flanges	Body material is certified acc. to 3.1 (EN 10204) for the following materials	
		acc to. EN	acc to. ASME
2	Cast steel	1.0619	WCB, WCC
4	Stainless steel	1.4404, 1.4571	316L, 316Ti
5	Nodular cast iron	0.7043	Ductile Gr. 60-40-18

Sample capacity table – How to select capacities for gas: Type 447 DN 50

Capacity table – air

Calculation of the capacity for gasses as per AD 2000-Merkblatt A2 with 10% overpressure at 0 °C and 1013 mbar.
Capacities at 1 bar (14,5 psig) and lower are calculated at 0,1 bar (1,45 psig) overpressure.

Metric units	1 AD 2000-Merkblatt A2 [m^3/h]			
DN _E	25	50	80	100
DN _A	50	3	80	150
Actual Orifice diameter d ₀ [mm]	23	46	4	60
Actual Orifice area A ₀ [mm ²]	415	5	1662	2827
LEO _{S/G} * [inch ²]	0,408	1,630	6	2,773
7 Set pressure [bar]	Capacity [kg/h]			
0,1	133	518	950	1898
0,2	169	661	1216	2467
0,3	202	790	8	1452

US units	ASME Section VIII [S.C.F.M.]			
DN _E	25	50	80	100
DN _A	50	80	100	150
Actual Orifice diameter d ₀ [inch]	0,91	1,81	2,36	3,62
Actual Orifice area A ₀ [inch ²]	0,645	2,576	4,382	10,304
LEO _{S/G} * [inch ²]	0,408	1,630	2,773	6,048
Set pressure [psig]	Capacity [S.C.F.M.]			
10	202	679	1256	2868
15	217	839	1528	3529

*LEO_{S/G/L} = LESER Effective Orifice for steam, gasses, and liquids, see page 18 and 19.

Explanation		Type 447 DN 50			
No.	Name		Metric units	US units	Example
1	Code				AD 2000-Merkblatt A2
2	Nominal diameter inlet	DN _i			50
3	Nominal diameter outlet	DN _o			80
4	Actual orifice diameter	d ₀	[mm]	[inch]	46
5	Actual orifice area	A ₀	[mm ²]	[inch ²]	1662
6	LESER Effective Orifice	LEO _{S/G}	[inch ²]	[inch ²]	1,630
7	Set pressure		[bar _g]	[psig]	0,3
8	Capacity		[kg/h]	[lb/h]	790
9	Calculation basis		See table on page 17		

9

Calculation basis

		Metric units		US units	
Code		Capacity calculation acc. to AD 2000-Merkblatt A2		Capacity calculation acc. to ASME Section VIII (UV)	
Medium					
Steam (Saturated steam)	Standard conditions	Steam table IAPWS-IF97 IAPWS Industrial Formulation for the Thermodynamic Properties of Water and Steam	[kg/h]	Steam table IAPWS-IF97 IAPWS Industrial Formulation for the Thermodynamic Properties of Water and Steam	[lb/h]
Air	Standard conditions	0 °C and 1013 mbar	[m _n ³ /h]	16 °C and (60 °F)	[S.C.F.M.]
Water	Standard conditions	20 °C	[10 ³ kg/h]	21 °C (70 °F)	[US-G.P.M.]
All media					
	Calculation pressure	Set pressure plus 10% overpressure		Set pressure plus 10% overpressure	
	Calculation pressure for low set pressures	Capacities at 1 bar and below are calculated with 0,1 bar overpressure.		Capacities at 2,07 bar (30 psig) and lower are calculated at 0,207 bar (3 psig) overpressure.	

Example

Determining the design pressure

Metric units	
Set pressure	Design pressure
10 bar	10 bar + 10% overpressure = 11 bar
0,5 bar	0,5 bar + 0,1 bar overpressure = 0,6 bar

6

LESER Effective Orifice

Safety devices against pressure overshoot should be determined using the equations as per API RP 520, Section 3.6 to 3.10 for steam, gases, liquids, or dual-phase flow. These equations use the coefficient of discharge (S/G 0,975, F 0,650) and the effective "Orifice" (as per API Std. 526, Fifth Edition, June 2002, table 1), which are independent of the valve construction.

This way, the system planner can determine a preliminary valve size. By using the LEO, the system planner can select the safety valve directly according to the calculation. A verification with the selected actual flow area and the accorded coefficient of discharge is not necessary.

See the LESER Engineering manual for more information.

The table is based on the accorded coefficient of discharge for steam and gases for ASME certified LESER safety valves. The associated K-values can be seen in the "K-value" column.

$$LEO_{S/G} [\text{inch}^2] = A_0 [\text{inch}^2] \cdot \left(\frac{K}{0,975} \right)$$

LEO _{S/G}		LESER Effective Orifice for steam and gases							
Orifice acc to. API 526	LESER series	DN	Inlet size	d ₀ [inch]	d ₀ [mm]	K-value ¹⁾	LEO _{S/G} [inch ²]	% of the larger orifice	% of the smaller orifice
D							0,110	100,0%	100,0%
E							0,196	100,0%	100,0%
F							0,307	100,0%	100,0%
	447	25	1"	0,906	23,0	0,617	0,408	81,0%	132,7%
	546	25	1"	0,906	23,0	0,703	0,482	95,5%	157,1%
G							0,503	100,0%	100,0%
H							0,785	100,0%	100,0%
	546	40	1 1/2"	1,457	37,0	0,680	1,162	90,3%	148,1%
Y							1,287	100,0%	100,0%
	447	50	2"	1,811	46,0	0,617	1,630	88,7%	126,7%
	546	50	2"	1,811	46,0	0,680	1,797	97,7%	139,6%
K							0,838	100,0%	100,0%
	447	80	3"	2,362	60,0	0,617	2,773	97,2%	150,9%
L							2,853	100,0%	100,0%
	546	65	2 1/2"	2,362	60,0	0,680	3,057	84,9%	107,1%
M							3,600	100,0%	100,0%
	546	80	3"	2,835	72,0	0,640	4,143	95,4%	115,1%
N							4,340	100,0%	100,0%
	546	100	3"	3,425	74,0	0,130	6,048	94,8%	139,4%
P							6,380	100,0%	100,0%
	447	100	4"	3,622	92,0	0,617	6,520	59,0%	102,2%
Q							11,050	100,0%	100,0%

¹⁾ There is no ASME approval for LESER Type 449. LEO values correspond to the specifications of Type 447, however they have to be confirmed by LESER as part of the specification on pages 59 and 60.

The table is based on the accorded coefficient of discharge for liquids for ASME certified LESER safety valves. The associated K-values can be seen in the "K-value" column.

$$LEO_L \text{ [inch}^2\text{]} = A_0 \text{ [inch}^2\text{]} \cdot \left(\frac{K}{0,650} \right)$$

LEO _L		LESER Effective Orifice for liquids							
Orifice acc to. API 526	LESER series	DN	Inlet size	d ₀ [inch]	d ₀ [mm]	K-value ¹⁾	LEO _L [inch ²]	% of the larger orifice	% of the smaller orifice
D							0,110	100,0%	100,0%
E							0,196	100,0%	100,0%
	447	25	1"	0,906	23,0	0,431	0,285	92,7%	69,9%
	546	25	1"	0,906	23,0	0,460	0,304	99,0%	74,6%
F							0,307	100,0%	100,0%
G							0,503	100,0%	100,0%
	546	40	1 1/2"	1,496	38,0	0,430	0,775	98,8%	60,2%
H							0,785	100,0%	100,0%
	447	50	2"	1,811	46,0	0,431	1,139	88,5%	69,9%
	546	50	2"	1,811	46,0	0,430	1,136	88,3%	69,7%
J							1,287	100,0%	100,0%
K							1,838	100,0%	100,0%
	546	65	2 1/2"	2,362	60,0	0,430	1,933	67,7%	67,7%
	447	50	3"	2,362	60,0	0,431	1,937	67,9%	67,9%
	546	80	3"	2,853	72,0	0,400	2,589	90,7%	90,7%
L							2,853	100,0%	100,0%
M							3,600	100,0%	100,0%
	546	100	4"	3,425	87,0	0,400	3,780	87,1%	59,3%
N							4,340	100,0%	100,0%
	447	100	4"	3,622	92,0	0,431	4,555	71,4%	69,9%
Q							6,380	100,0%	100,0%

¹⁾ There is no ASME approval for LESER Type 449. LEO values correspond to the specifications of Type 447, however they have to be confirmed by LESER as part of the specification on pages 59 and 60.

Example of determination of K_{dr}/α_w : Type 447 DN 50

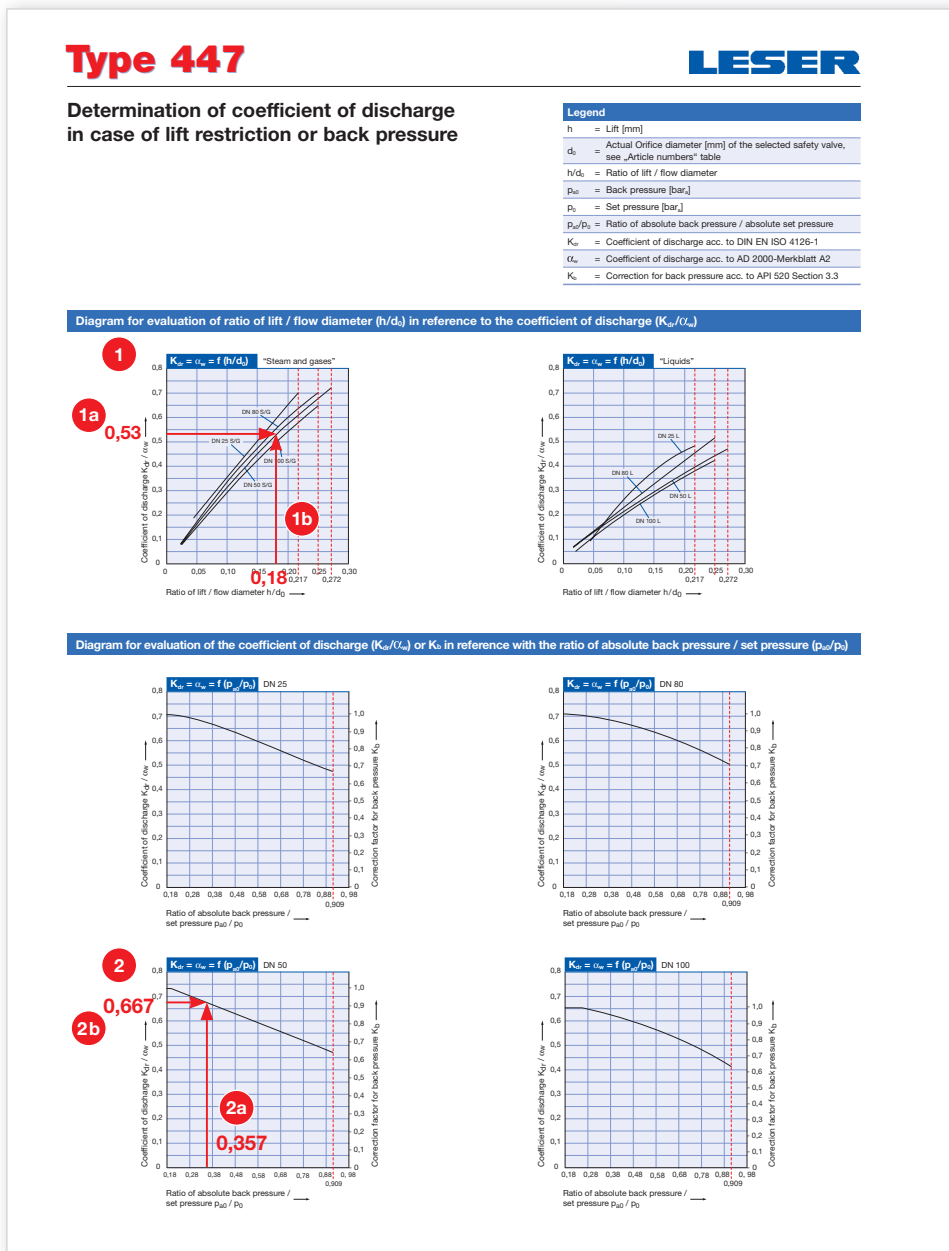

Explanation Example – Type 447, flow diameter $d_0 = 46$ mm, Lift $h = 8,2$ mm, K_{dr}/α_w S/G = 0,667

1 Diagram 1 Determining the restricted lift due to reduced K_{dr}/α_w			2 Diagram 2 Determination of reduced K_{dr}/α_w or K_b ¹⁾ due to back pressure		
Step	Description	Example	Step	Description	Example
1	Calculation of the necessary coefficient of discharge for the selected safety valve. The applicable formulas are to be taken from the rules and regulations.	1a $K_{dr}/\alpha_w = 0,53$	1	Calculation of the back pressure p_{a0}/p_0 with the use of the set pressure p_0 [bar _a] 2,1 and the back pressure p_{a0} [bar _a] 0,75	2a $p_{a0}/p_0 = 0,357$
2	Choose the starting point (0,53) on the Y-axis of the chart.		2	Choose the starting point (0,357) on the X-axis of the chart.	
3	Draw a horizontal line to determine the intersection point of the curves.		3	Draw a vertical line to determine the intersection point of the curves.	
4	Draw a vertical line through the intersection point on the X-axis to determine the ratio of lift / flow diameter (h/d_0).	1b $h/d_0 = 0,18$	4	Draw a horizontal line through the intersection point on the Y-axis to determine the reduced coefficient of discharge K_{dr}/α_w .	2b $K_{dr}/\alpha_w = 0,667$
5	Calculation of the lift restriction with the formula $h = d_0 \times h/d_0$. (To order the lift restriction, please choose option code J51; see page 70).	$h = 46 \times 0,18$ $h = 8,2$ mm	5	Calculation of the valve with the established coefficient of discharge K_{dr}/α_w or the correction factor for back pressure K_b .	

¹⁾ Correction factors for back pressure K_b , as per API 520 Section 3.3. See the LESER Engineering Manual for more information.



Type 447

Flange Safety Relief Valves – spring loaded

Contents	Page
Material	
• Conventional design – Level 3	22
• Chlorine application – Level 3	24
How to order	
• Numbering system	26
• Article numbers	28
Dimension and weights	
• Metric and US units	29
Pressure temperature ratings	
• Metric and US units	30
Order information	
• Flange drillings	31
• Spare parts	31
Available options	32
Approvals	33
Capacities – Metric units	
• Steam, Air, Water	34
Capacities – US units	
• Steam, Air, Water	35
Determination of coefficient of discharge K_{dr}/α_w	36

Type 447
PTFE-lined
Packed lever H4
Closed bonnet
Bellows design

Conventional design – Level 3

Type 447

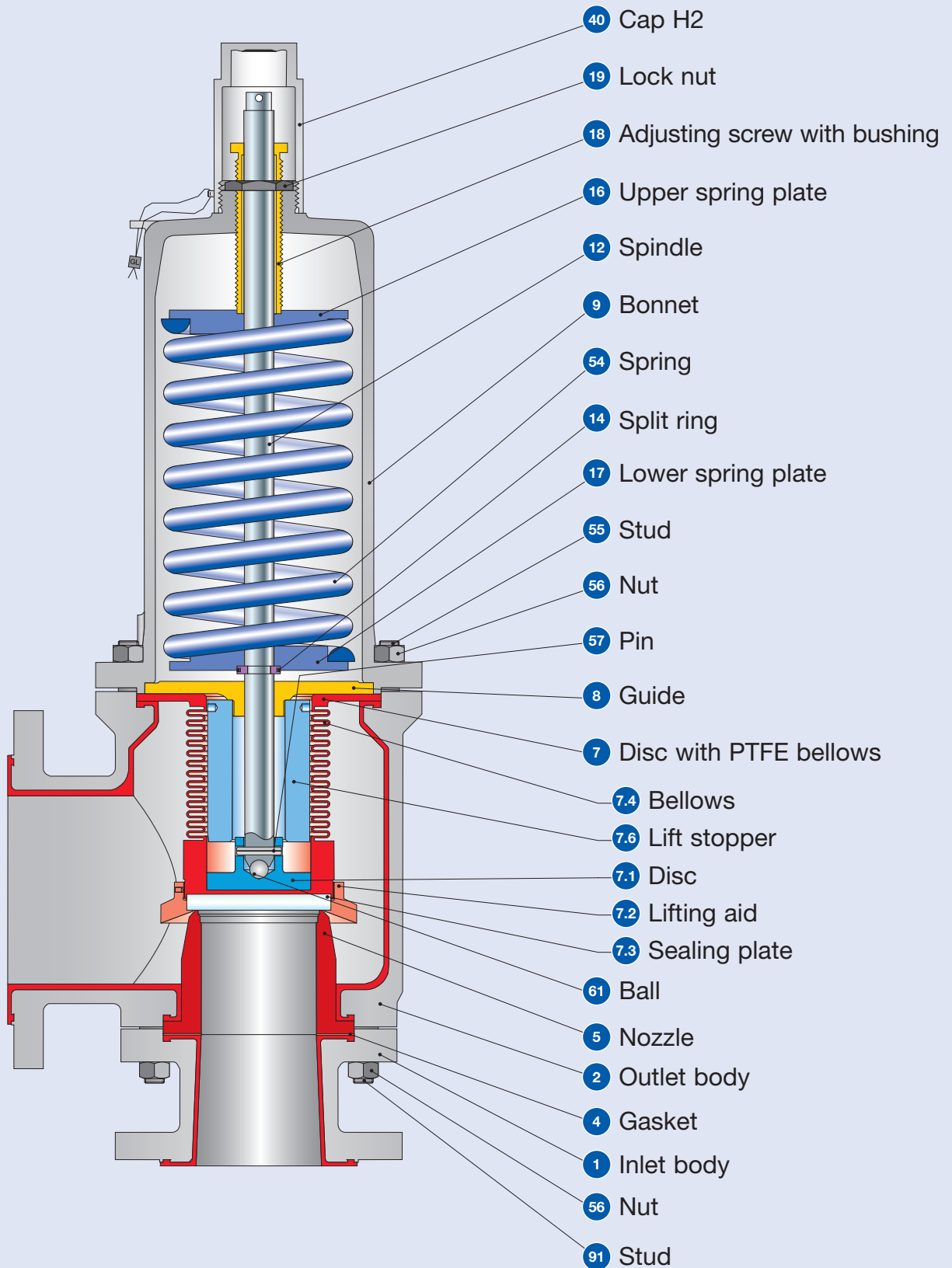

Conventional design – Level 3

Materials		Type 447
Item	Components	Type 447
1	Inlet body	1.0460 + Virgin PTFE-TF Steel + Virgin PTFE-TF
2	Outlet body	1.0619 + Virgin PTFE-TF SA 216 WCB + Virgin PTFE-TF
4	Gasket	Gylon®
5	Nozzle	PTFE-TFM + 25 % glass
7	Disc with PTFE bellows	1.4404 + PTFE 316L + PTFE
7.1	Disc	1.4404 316L
7.2	Lifting aid	PTFE-TFM + 25 % glass
7.3	Sealing plate	BOROFLOAT glass
7.4	Bellows	PTFE-TFM
7.6	Lift stopper	1.4404 316L
8	Guide	1.4404 316L
9	Bonnet	0.7040 Ductile Gr. 60-40-18
12	Spindle	1.4404 Stainless steel
14	Split ring	1.4104 Chrome steel
16/17	Spring plate	1.0718 Steel
18	Adjusting screw with bushing	1.4104 PTFE Chrome steel PTFE
19	Lock nut	1.0718 Steel
40	Cap H2	1.0460 SA 105
54	Spring, standard	1.1200, 1.8159 Steel
	Spring, optional	1.4310 Stainless steel
55	Stud	1.1181 Steel
56	Nut	1.0501 2H
57	Pin	1.4310 Stainless steel
61	Ball	1.3541 Hardened stainless steel
91	Stud	1.1181 Steel

Please observe:

- LESER reserves the right to make changes.
- LESER may use higher quality materials without giving prior notice.
- Each component can be replaced by another material according to the customer's specification.
- All components exposed to pressure are highlighted in bold.

Chlorine application – Level 3

For applications with chlorine, there must be differentiation made between the states of the chlorine. If the application uses chlorine in a gaseous state, then the standard version of a LESER Critical Service Safety Valve Type 447 can be used. Chlorine takes the form of gas if no water-dissolved

chlorine is present or the chlorine gas does not come into contact with moisture. The reducing effect of chlorine is amplified when water-dissolved chlorine exists. Hydrochloric acid (HCl) with a highly corrosive effect is formed even when chlorine is exposed only to atmospheric humidity (wet

Type 447

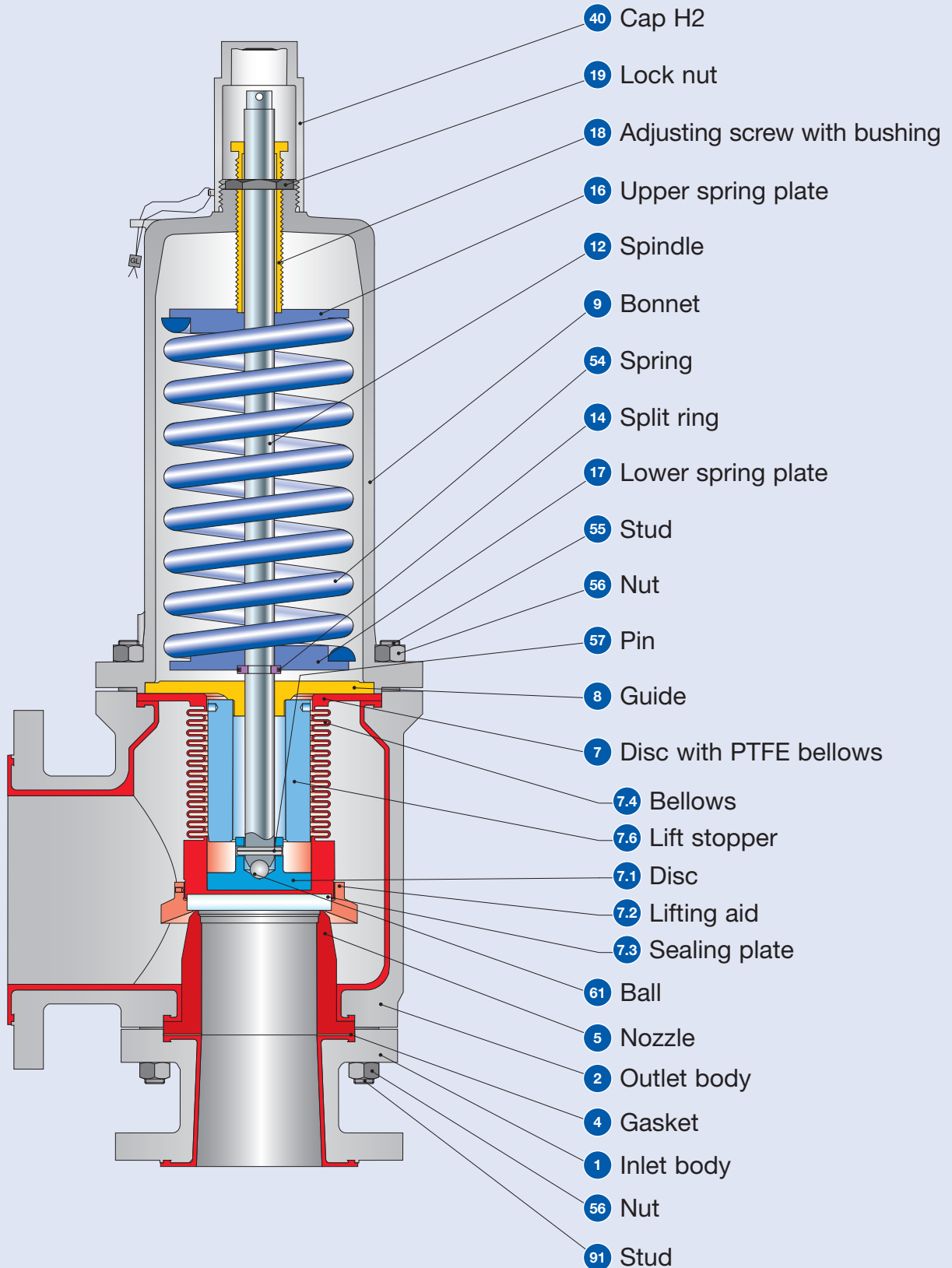

Chlorine application – Level 3

chlorine). Because a diffusion in the bonnet space cannot be entirely eliminated when long-term exposure to humid chlorine exists, LESER recommends the use of Type 447 chlorine. Also with applications using gaseous chlorine, it should be ascertained whether chlorine may possibly come into contact

with atmospheric humidity, for example at the outlet of the safety valve. If this is the case, LESER also recommends the use of Type 447 chlorine for this instance.

Materials		
Item	Components	Type 447 Chlorine
1	Inlet body	1.0570 + Virgin PTFE SA105 + PTFE-TF
2	Outlet body	1.0619 + Virgin PTFE WCB + PTFE-TF
4	Gasket	Gylon®
5	Nozzle	PTFE-TFM + 25% glass
7	Disc with PTFE bellows	2.4610 / PTFE
7.1	Disc	2.4610 Hastelloy C-4
7.2	Lifting aid	PTFE-TFM + 25% glass
7.3	Sealing plate	BOROFLOAT glass
7.4	PTFE bellows	PTFE-TFM
7.6	Lift stopper	PTFE-TFM + 25% glass
8	Guide with bushing	1.4404 + 2.4610 316L + Hastelloy C-4
9	Bonnet	0.7040 Duktil Gr. 60-40-18 Interior is coated with chlorine-resistant vinyl ester resin coating, with SGL Carbon CEILCOTE 232 Flakeline, coating thickness 160 µm
12	Spindle	2.4610 Hastelloy C-4
14	Split ring	2.4610 Hastelloy C-4
16/17	Spring plate	1.4404 316L
18	Adjusting screw with bushing	1.4404 + PTFE-TF 316L + PTFE-TF
19	Lock nut	1.0718 Steel
40	Cap H2	1.0460 SA 105
54	Spring	1.4310 Stainless steel
55	Stud	1.1181 Steel
56	Nut	1.0501 2H
57	Pin	2.4610 Hastelloy C-4
61	Ball	2.4610 machined on the spindle Hastelloy C-4 machined on the spindle
91	Stud	1.1181 Steel

Please observe:

LESER reserves the right to make changes. LESER may use higher quality materials without giving prior notice. Each component can be replaced by another material according to the customer's specification. All components exposed to pressure are highlighted in bold.

How to order – Numbering system

1

Article number

4472.3872

2

Set pressure

10 bar_g

3

Connections

H64

1	2	3	4
447	2	387	2

1 Valve Type 447

Type	Page
447 – Lining: virgin PTFE	28
546 – with PTFE-Nozzle	45
5466 – with PTFE-Carbon-Nozzle	45
449 – with bore system for gasmasking	57

2 Material code

Code	Body material
2	1.0619 (WCB)
4	1.4571 (316Ti)
5	0.7043 (ductile Gr. 60-40-80)

3 Valve code

Identifies valve size and body material

4

Code	Lifting device	
2	Screwed cap	H2
4	Packed lever	H4

Please state unit (in gauge)!

Please do not exceed the pressure range defined in the spring charts.

See tablet „Flange drillings“ on page 31.

Please state one option code for each, inlet **and** outlet.

4 Options

J51

Type 447, 546, 449	Option code
• PTFE-TF lining, virginal	Standard
• PTFE-TFM lining, conductive	Please specify when ordering
• Stainless steel spring	X04
• Lift restriction	J51
• Connection for lift indicator H4	J39
• Lift indicator	J93
• Test gag	
- Cap	H2 J70
- Packed lever	H4 J69
• Free of oil and grease	J85
• Chlor applications	Please specify when ordering
- Dry chlorine	
- Chlorine, wet	
Option code applies only if not standard	

5 Documentation

H01 L30

Please select the necessary documentation:

Tests, Certifications:	Option code
DIN EN 10204-3.2: TÜV-Nord Certification for set pressure	M33
LESER Certificate for Global Application	H03
- Acceptance test certificate 3.1 as per DIN EN 10204	
- Declaration of conformity as per pressure equipment directive 97/23/EC	
Material quality certificate: DIN EN 10204-3.1	
Component	Option code
Inlet body	H01
Outlet body	L34
Bonnet	L30
Cap / lever cover	L31
Disc with bellows	L23
Studs	N07
Nuts	N08
Quality of coating: Sparc test DIN 28055-2, DIN EN 10204 2.2	

6 Code and Medium

2.0

1	2
2	0
1 Rules and regulations	
1. ASME Section VIII	
2. CE / VdTUEV	
3. ASME Section VIII + CE / VdTUEV	
2 Medium	
.1 Gases	
.2 Liquids	
.0 steam / gases / liquids	
(only applicable for CE / VdTUEV)	

Article numbers

Type 447

DN _i	25	50	80	100
DN _o	50	80	100	150
Valve size	1" x 2"	2" x 3"	3" x 4"	4" x 6"
Actual Orifice diameter d _o [mm]	23	46	60	92
Actual Orifice area A _o [mm ²]	415	1662	2827	6648

Body material: 1.0619 + virgin PTFE-TF (WCB + PTFE-TF)

PTFE fully lined

Bonnet closed	H2	Art.-No. 4472.	3872	3882	3892	3902
	H4	Art.-No. 4472.	3874	3884	3894	3904

Note on export restrictions see page 71



Type 447
Cap H2
Closed bonnet
Conventional design



Type 447
Packed lever H4
Closed bonnet
Conventional design

Dimensions and weights

Metric units					
	DN _i	25	50	80	100
	DN _o	50	80	100	150
	Valve size	1" x 2"	2" x 3"	3" x 4"	4" x 6"
	Actual Orifice diameter d ₀ [mm]	23	46	60	92
	Actual Orifice area A ₀ [mm ²]	416	1662	2827	6648
Weight [kg]					
		15	29	50	105
Centre to face [mm]	Inlet a	105	152	155	220
	Outlet b	100	120	155	200
Height (H4) [mm]					
		468	604	786	943
Body material: 1.0619 + virgin PTFE-TF (WCB + PTFE-TF)					
DIN Flange¹⁾	Inlet			PN 16	
	Outlet			PN 16	
US units					
	DN _E	25	50	80	100
	DN _A	50	80	100	150
	Valve size	1" x 2"	2" x 3"	3" x 4"	4" x 6"
	Actual Orifice diameter d ₀ [inch]	0,91	1,81	2,36	3,62
	Actual Orifice area A ₀ [inch ²]	0,645	2,576	4,382	10,304
Weight [lbs]					
		33	64	110	231
Centre to face [inch]	Inlet a	4 ¹ / ₄	6	6 ¹ / ₈	8 ³ / ₄
	Outlet b	3 ⁷ / ₈	4 ³ / ₄	6 ¹ / ₈	7 ⁷ / ₈
Height (H4) [inch]					
		18 ¹ / ₄	23 ³ / ₄	30 ¹⁵ / ₁₆	37 ¹ / ₈
Body material: 1.0619 + virgin PTFE-TF (WCB + PTFE-TF)					
DIN Flange¹⁾	Inlet			PN 16	
	Outlet			PN 16	
ASME Flange¹⁾	Inlet			Class 150	
	Outlet			Class 150	

¹⁾ Standard flange class. For other flange drillings, see page 31.

Conventional design

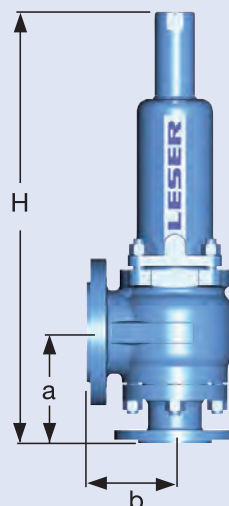

Pressure temperature ratings

Metric units

DN _i	25	50	80	100
DN _o	50	80	100	150
Valve size	1" x 2"	2" x 3"	3" x 4"	4" x 6"
Actual Orifice diameter d _o [mm]	23	46	60	92
Actual Orifice area A _o [mm ²]	416	1662	2827	6648

Body material: 1.0619 + virgin PTFE (WCB + PTFE-TF)

DIN Flange	Inlet	PN 16		
	Outlet	PN 16		
Min. set pressure	p [bar _g] S/G/L	0,1		
Max. set pressure with special spring¹⁾	p [bar _g] S/G/L	16	10	10
		16	16	16
Temperature¹⁾ acc. to DIN EN	min. [°C]	-85		
	max. [°C]	+200		

US units

DN _i	25	50	80	100
DN _o	50	80	100	150
Valve size	1" x 2"	2" x 3"	3" x 4"	4" x 6"
Actual Orifice diameter d _o [inch]	0,91	1,81	2,36	3,62
Actual Orifice area A _o [inch ²]	0,645	2,576	4,382	10,304

Body material: 1.0619 + virgin PTFE (WCB + PTFE-TF)

ASME Flange	Inlet	Class 150		
	Outlet	Class 150		
Min. set pressure	p [psig] S/G/L	1,45		
Max. set pressure with special spring¹⁾	p [psig] S/G/L	232	145	145
		232	232	232
Temperature¹⁾ acc. to DIN EN	min. [°F]	-121		
	max. [°F]	+392		

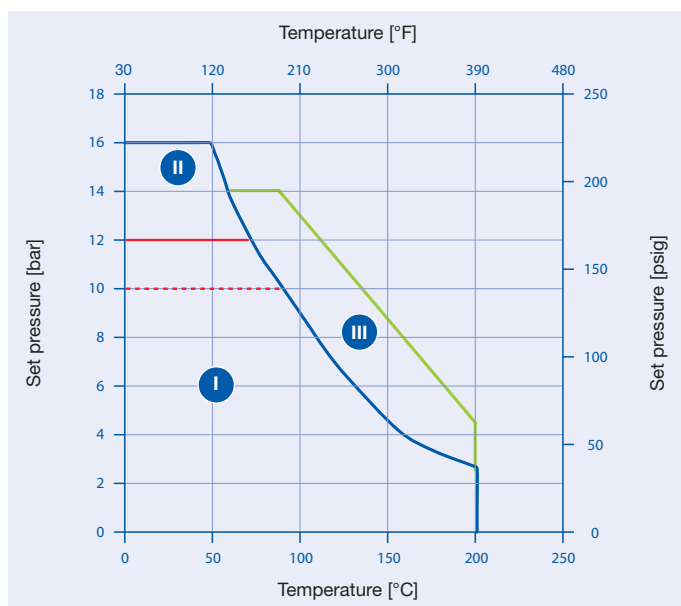

Pressure temperature ratings

¹⁾ The pressure / temperature functional ranges of Type 447 are dependent on the PTFE components in the safety valve. The chart shows the application ranges for:

- I Standard safety valve with PTFE nozzle and sealing plate made of BOROFLOAT glass
- II Design for pressures above 10 bar or 12 bar: Safety valve with metallic nozzle and sealing plate of Hastelloy®, nickel-base alloys, etc.
- III Safety valve with metallic nozzle, sealing plate and lifting aid of Hastelloy®, nickel-base alloys, etc.

Additional order codes are required for ordering

Nominal diameter	Set pressure [bar]	Option code
DN 25	12,01 – 16	S05 + S07
DN 50	10,01 – 16	S05 + S07 + S54
DN 80	10,01 – 16	S05 + S07 + S54
DN 100	10,01 – 16	S05 + S07 + S54

Order informationen – Flange drillings and Spare parts

Flange drillings						
		DN _i	25	50	80	100
		DN _o	50	80	100	150
		Valve size	1" x 2"	2" x 3"	3" x 4"	4" x 6"
		Actual Orifice diameter d _o [mm]	23	46	60	92
		Actual Orifice area A _o [mm ²]	415	1662	2827	6648
Body material: 1.0619 (WCB)						
Inlet	DIN EN 1092	PN 10	H44	H44	H44	H44
		PN 16	*	*	*	*
Outlet	DIN EN 1092	PN 10	H50	H50	H50	H50
		PN 16	*	*	*	*
Inlet	ASME B16.5	CL150	H64	H64	H64	H64
Outlet	ASME B16.5	CL150	H79	H79	H79	H79

Spare parts						
		DN _i	25	50	80	100
		DN _o	50	80	100	150
		Valve size	1" x 2"	2" x 3"	3" x 4"	4" x 6"
		Actual Orifice diameter d _o [mm]	23	46	60	92
		Actual Orifice area A _o [mm ²]	416	1662	2827	6648
Material-No. / Art.-No.						
Gasket (Item 4)		Gylon®	500.4205.0000	500.4305.0000	500.4405.0000	500.4505.0000
Nozzle (Item 5)		PTFE-TFM + 25 % glass	207.0659.0000	207.1159.0000	207.1659.0000	207.0359.0000
Disc (Item 7.1)		1.4404	212.1649.0000	212.1749.0000	212.3649.0000	212.1849.0000
Lifting aid (Item 7.2)		PTFE-TFM + 25 % glass	341.5759.0000	341.5859.0000	341.2859.0000	341.5659.0000
Sealing plate (Item 7.3)		BOROFLOAT glass	236.2459.0000	236.2559.0000	236.1859.0000	236.2359.0000
Bellows (Item 7.4)		PTFE-TFM	224.1659.0000	224.1759.0000	224.2259.0000	224.1559.0000
Set screw (Item 7.5)		PTFE + 25% glass	2 x 453.0208.0000	2 x 453.0208.0000	2 x 453.0208.0000	2 x 453.0208.0000
Ball (Item 61)		Ball Ø [mm]	9	9	12	15
		1.4401	510.0204.0000	510.0204.0000	510.0304.0000	510.0404.0000
Split ring (Item 14)		Spindle Ø [mm]	16	16	24	24
		1.4404	251.0249.0000	251.0249.0000	251.0449.0000	251.0449.0000
Pin (Item 57)		1.4310	480.0605.0000	480.0705.0000	480.2605.0000	480.2605.0000

Available options

For further information, refer to
“Accessories and options”, page 61

Screwed cap H2
H2



Packed lever H4
H4

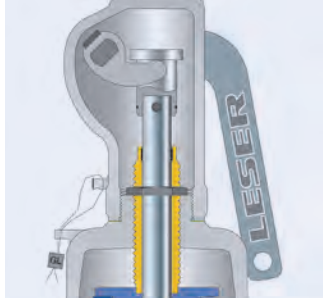

Lift indicator
J39: Connection H4
J93: Lift indicator

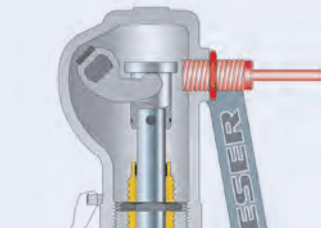

Lift stopper
J51

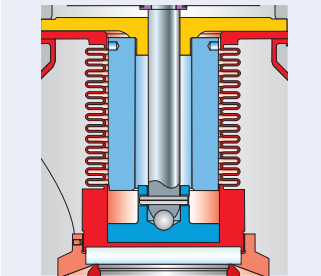

Special materials
2.4610 Hastelloy® C4
2.4360 Monel® 400
1.4462 Duplex

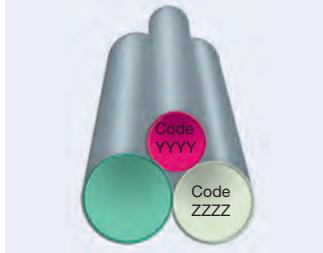

Approvals

Approvals					
	DN _i	25	50	80	100
	DN _o	50	80	100	150
	Valve size	1" x 2"	2" x 3"	3" x 4"	4" x 6"
	Actual Orifice diameter d ₀ [mm]	23	46	60	92
	Actual Orifice area A ₀ [mm ²]	416	1662	2827	6648
Europe		Coefficient of discharge K _{dr}			
DIN EN ISO 4126-1	Approval No.	072020111Z0008/0/09			
	S/G	0,70	0,72	0,70	0,65
	L	0,48	0,47	0,51	0,42
Germany		Coefficient of discharge C _w			
AD 2000-Merkblatt A2	Approval No.	SV05-979			
	S/G	0,70	0,72	0,70	0,65
	L	0,48	0,47	0,51	0,42
United States		Coefficient of discharge K			
ASME Sec. VIII	Approval No.	M37123			
	G	0,617			
	Approval No.	M37134			
	L	0,431			
Canada		Coefficient of discharge K			
CRN	Approval No.	For current approval no. see www.leser.com			
	G	0,617			
	L	0,431			
China		Coefficient of discharge C _w			
AQSIQ	Approval No.	For current approval no. see www.leser.com			
	S/G	0,70	0,72	0,70	0,65
	L	0,48	0,47	0,51	0,42
Eurasian Custom Union		Coefficient of discharge C _w			
EAC	Approval No.	For current approval no. see www.leser.com			
	S/G	0,70	0,72	0,70	0,65
	L	0,48	0,47	0,51	0,42
Classification societies		on request			

Capacities acc. to AD 2000-Merkblatt A2

Calculation of the capacity for steam, air and water acc. to. AD 2000-Merkblatt A2 with 10% overpressure at 0 °C and 1013 mbar (air) or alternatively 20 °C (water). Capacities at 1 bar and lower are calculated at 0,1 bar overpressure.

Metric units		AD 2000-Merkblatt A2											
		Steam				Air				Water			
DN _E		25	50	80	100	25	50	80	100	25	50	80	100
DN _A		50	80	100	150	50	80	100	150	50	80	100	150
Actual Orifice diameter d ₀ [mm]		23	46	60	92	23	46	60	92	23	46	60	92
Actual Orifice area A ₀ [mm ²]		415	1662	2827	6648	415	1662	2827	6648	415	1662	2827	6648
LEO _{S/G/L} ^{*)} [inch ²]		0,408	1,630	2,773	6,048	0,408	1,630	2,773	6,048	0,285	1,139	1,937	4,555
Set pressure [bar]	Capacity [kg/h]	Capacity [m ³ /h]				Capacity [10 ³ kg/h]							
0,1	115	450	826	1649	133	518	950	1898	4,5	17,8	32,9	63,5	
0,2	146	571	1051	2132	169	661	1216	2467	5,6	21,8	40,3	77,8	
0,3	173	679	1249	2563	202	790	1452	2981	6,4	25,1	46,5	89,8	
0,4	198	777	1424	2950	231	908	1665	3447	7,2	28,1	52,0	100,4	
0,5	220	867	1584	3305	259	1018	1859	3880	7,9	30,8	56,9	110,0	
0,6	241	952	1729	3631	284	1122	2039	4281	8,5	33,2	61,5	118,8	
0,7	260	1030	1862	3931	308	1219	2204	4652	9,1	35,5	65,7	127,0	
0,8	279	1104	1987	4212	331	1311	2359	2002	9,6	37,7	69,7	134,7	
0,9	297	1178	2109	4490	353	1401	2509	5341	10,1	39,7	73,5	142,0	
1,0	315	1252	2230	4763	375	1491	2657	5675	10,6	41,7	77,1	148,9	
1,1	335	1332	2361	5058	399	1590	2818	6037	11,2	43,7	80,8	156,2	
1,2	354	1413	2491	5353	424	1689	2978	6400	11,7	45,7	84,4	163,2	
1,3	374	1492	2620	5643	448	1787	3137	6757	12,1	47,5	87,9	169,8	
1,4	393	1573	2748	5933	472	1886	3295	7115	12,6	49,3	91,2	176,2	
1,5	413	1653	2875	6221	496	1985	3453	7471	13,0	51,0	94,4	182,4	
1,6	432	1733	3001	6505	520	2084	3609	7825	13,5	52,7	97,5	188,4	
1,7	452	1812	3127	6790	544	2183	3765	8177	13,9	54,3	100,5	194,2	
1,8	471	1891	3251	7070	568	2280	3920	8525	14,3	55,9	103,4	199,8	
1,9	490	1971	3375	7351	592	2379	4075	8874	14,7	57,4	106,3	205,3	
2,0	510	2051	3500	7633	616	2479	4230	9225	15,1	58,9	109,0	210,6	
2,1	529	2129	3623	4353	640	2577	4383	9572	15,4	60,4	111,7	215,8	
2,2	548	2209	3746	8189	664	2676	4537	9919	15,8	61,8	114,3	220,9	
2,3	567	2288	3868	8465	688	2774	4691	10265	16,1	63,2	116,9	225,9	
2,4	587	2367	3991	8742	712	2873	4844	10611	16,5	64,6	119,4	230,7	
2,5	606	2367	4112	9017	736	2972	4997	10956	16,8	65,9	121,9	235,5	
2,6	625	2524	4233	9289	760	3069	5148	11298	17,2	67,2	124,3	240,2	
2,7	644	2603	4355	9565	784	3169	5301	11644	17,5	68,5	126,7	244,7	
2,8	663	2681	4475	9882	807	3266	5453	12041	17,8	69,7	129,0	249,2	
2,9	682	2760	4596	10139	832	3366	5605	12365	18,1	71,0	131,3	253,6	
3	701	2838	4716	10396	855	3464	5757	12688	18,4	72,2	133,5	258,0	
4					1072	4410	7294	15924	21,3	83,3	154,2	297,9	
5					1290	5306	8776	19160	23,8	93,2	172,4	333,0	
6					1507	6202	10258	22396	26,1	102,7	188,8	364,8	
7					1725	7098	11741	25632	28,2	110,2	203,9	394,1	
8					1943	7994	13223	28868	30,1	117,9	218,0	421,3	
9					2161	8890	14705	32104	31,9	125,0	231,2	446,8	
10					2379	9786	16187	35340	33,6	131,8	243,7	471,0	
11					2596	10682	17669	38575	35,3	138,2	255,4	494,0	
12					2814	11579	19152	41811	36,9	144,3	267,0	515,9	
13					3032	12475	20634	45074	38,4	150,2	277,9	537,0	
14					3250	13371	22116	48283	39,8	155,9	288,4	557,3	
15					3468	14267	23598	51519	41,2	161,4	298,5	576,8	
16					3685	15163	25080	54755	42,6	166,7	308,3	595,8	

Application not possible due to the pressure and temperature ranges of the PTFE nozzle.

^{*)} LEO_{S/G/L} = LESER Effective Orifice steam/gases/liquids see page 18/19. "How to use" capacity tables, see page 16.

Capacities acc. to ASME Section VIII

Calculation of the capacity for steam, air and water according to ASME Section VIII (UV) with 10% pressure increase at 60° F (air) or 70 °F (water). Capacities at 30 psig and lower are calculated at 3 psig overpressure.

US units		ASME Section VIII											
		Steam				Air				Water			
DN _i		25	50	80	100	25	50	80	100	25	50	80	100
DN _o		50	80	100	150	50	80	100	150	50	80	100	150
Actual Orifice diameter d _o [inch]		0,91	1,81	2,36	3,62	0,91	1,81	2,36	3,62	0,91	1,81	2,36	3,62
Actual Orifice area A _o [inch ²]		0,645	2,576	4,382	10,304	0,645	2,576	4,382	10,304	0,645	2,576	4,382	10,304
LEO _{S/G/L} ^{*)} [inch ²]		0,408	1,630	2,773	6,048	0,408	1,630	2,773	6,048	0,285	1,139	1,937	4,555
Set pressure [psig]	Capacity [lb/h]	Capacity [S.C.F.M.]				Capacity [US-G.P.M]							
5													
10						202	679	1256	2868	38,0	152,1	258,8	608,5
15						217	839	1528	3529	44,7	179,0	304,5	716,0
20						257	1000	1794	4175	50,6	202,3	344,2	809,3
25						297	1160	2055	4810	55,8	223,2	379,8	893,0
30						338	1321	2314	5439	60,6	242,4	412,3	969,4
35						382	1498	2596	6124	65,4	261,8	445,4	1047,1
40						426	1674	2876	6806	70,0	279,9	476,1	1119,4
45						468	1850	3155	7484	74,2	296,8	505,0	1187,3
50						508	2026	3433	8125	78,2	312,9	532,3	1251,5
55						548	2192	3728	8766	82,0	328,2	558,3	1312,6
60						588	2352	4001	9407	85,7	342,7	583,1	1371,0
65						628	2512	4274	10048	89,2	356,7	606,9	1427,0
70						668	2672	4547	10689	92,6	370,2	629,8	1480,8
75						708	2833	4819	11331	95,8	383,2	651,9	1532,8
80						748	2993	5092	11972	98,9	395,8	673,3	1583,1
85						788	3153	5365	12613	102,0	408,0	694,1	1631,8
90						828	3314	5637	13254	104,9	419,8	714,2	1679,1
95						868	3474	5910	13895	107,8	431,3	733,7	1725,1
100						909	3634	6183	14536	110,6	442,5	752,8	1769,9
110						989	3955	6728	15819	116,0	464,1	789,5	1856,3
120						1069	4275	7274	17101	121,2	484,7	824,7	1938,9
130						1149	4596	7819	18383	126,1	504,5	858,3	2018,0
140						1229	4916	8364	19666	130,9	523,6	890,7	2094,2
150						1309	5237	8910	20948	135,5	541,9	922,0	2167,7
160						1389	5558	9455	22230	139,9	559,7	952,2	2238,8
170						1470	5878	10001	23513	144,2	576,9	981,5	2307,7
180						1550	6199	10546	24795	148,4	593,7	1010,0	2374,6
190						1630	6519	11091	26077	152,5	609,9	1037,7	2439,7
200						1710	6840	11637	27359	156,4	625,8	1064,6	2503,1
210						1790	7160	12182	28642	160,3	641,2	1090,9	2564,9
220						1870	7481	12728	29924	164,1	656,3	1116,6	2625,2
230						1950	7802	13273	31206	167,8	671,1	1141,7	2684,2

Currently no ASME approval for saturated steam applications

*) LEO_{S/G/L} = LESER Effective Orifice steam/gases/liquids see page 18/19. "How to use" capacity tables, see page 16.

Determination of coefficient of discharge in case of lift restriction or back pressure

Legend

h	= Lift [mm]
d_0	= Actual Orifice diameter [mm] of the selected safety valve, see „Article numbers“ table
h/d_0	= Ratio of lift / narrowest flow diameter
p_{a0}	= Back pressure [bar _a]
p_0	= Set pressure [bar _a]
p_{a0}/p_0	= Ratio of absolute back pressure / absolute set pressure
K_{dr}	= Coefficient of discharge acc. to DIN EN ISO 4126-1
α_w	= Coefficient of discharge acc. to AD 2000-Merkblatt A2
K_b	= Correction for back pressure acc. to API 520 Section 3.3

Diagram for evaluation of ratio of lift / flow diameter (h/d_0) in reference to the coefficient of discharge (K_{dr}/α_w)

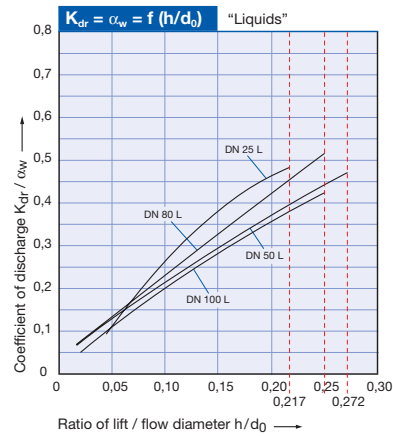
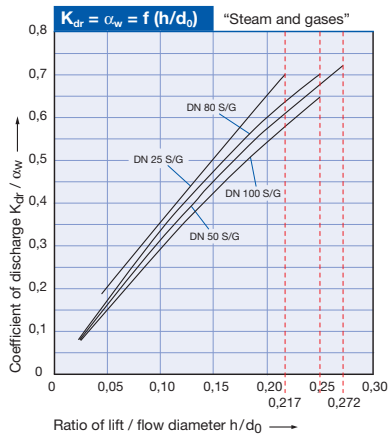
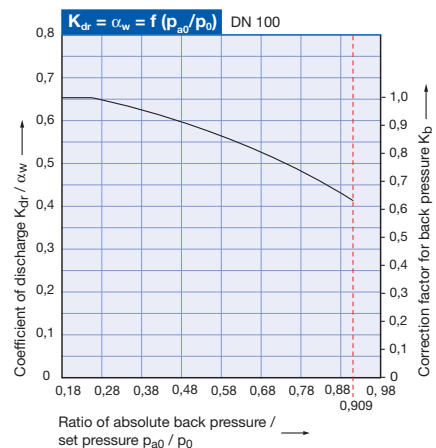
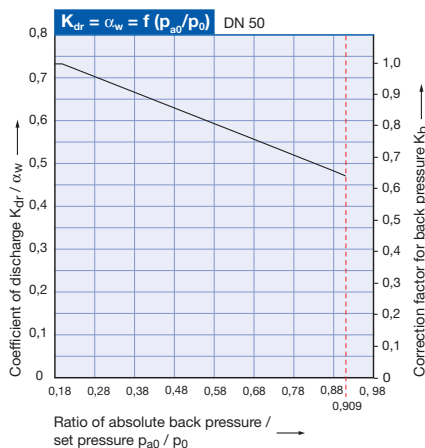
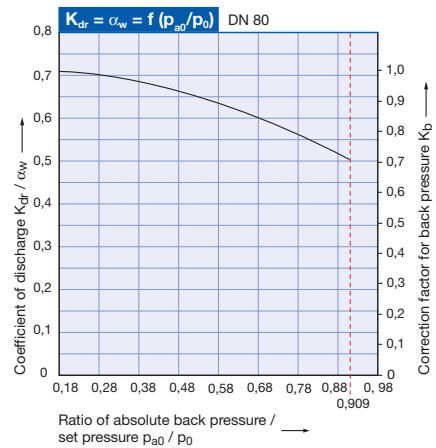
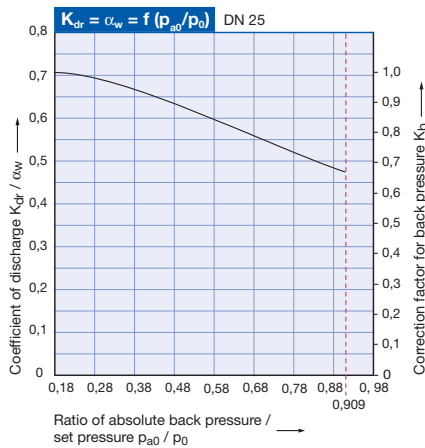
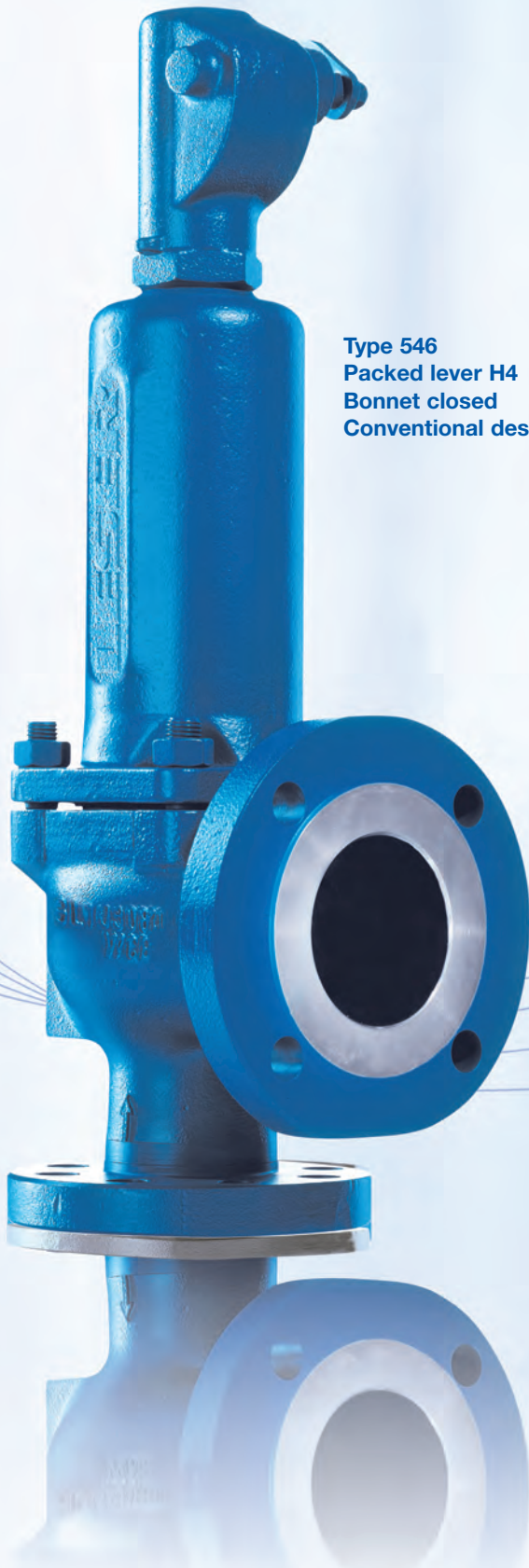

Diagram for evaluation of the coefficient of discharge (K_{dr}/α_w) or K_b in reference with the ratio of absolute back pressure/set pressure (p_{a0}/p_0)





Type 546
Packed lever H4
Bonnet closed
Conventional design

Type 546, 5466

Flanged Safety Relief Valve – spring loaded

Contents	Page
Materials – Type 546	
• Conventional design – Level 1	38
• Balanced bellows design – Level 1	40
Materials – Type 5466	
• PTFE bellows design – Level 2	42
How to order	
• Article numbers	44
Dimensions and weights	
• Metric units	46
Pressure temperature ratings	
• Metric units	47
Order information	
• Flange drillings	48
• Spare parts	49
Available options	50
Approvals	51
Capacities	
Type 546 – Metric units	52
• Steam, Air, Water	
Type 5466 – Metric units	53
• Steam, Air, Water	
Determination of coefficient of discharge K_{dr}/α_w	54

Conventional design – Level 1

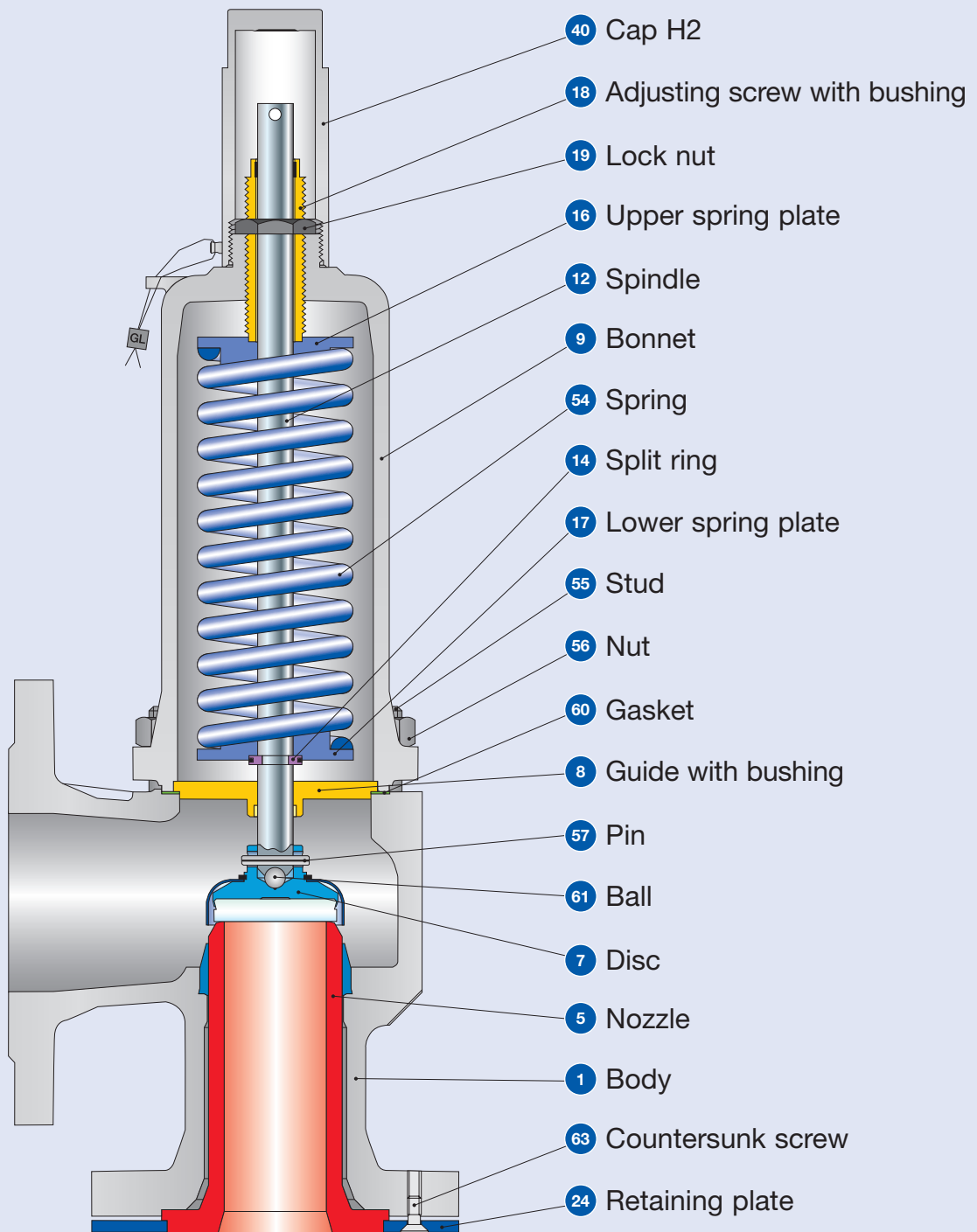

Conventional design – Level 1

Materials			
Item	Components	Type 5462	Type 5465
1	Body	1.0619 SA 216 WCB	0.7043 Ductile Gr. 60-40-18
5	Nozzle	Virgin PTFE PTFE-TF	Virgin PTFE PTFE-TF
7	Disc	1.4404 / BOROFLOAT glass 316L / BOROFLOAT glass	1.4404 / BOROFLOAT glass 316L / BOROFLOAT glass
8	Guide	1.4404 Stainless steel	1.4404 Stainless steel
9	Bonnet	0.7040 Ductile Gr. 60-40-18	0.7040 Ductile Gr. 60-40-18
12	Spindle	1.4404 Stainless steel	1.4404 Stainless steel
14	Split ring	1.4104 Chrome steel	1.4104 Chrome steel
16/17	Spring plate	1.0718 Steel	1.0718 Steel
18	Adjusting screw with bushing	1.4104 PTFE Chrome steel PTFE	1.4104 PTFE Chrome steel PTFE
19	Lock nut	1.0718 Steel	1.0718 Steel
24	Retaining plate	1.0036 Steel	1.0036 Steel
40	Cap H2	1.0460 SA 105	1.0460 SA 105
54	Spring, standard	1.1200, 1.8159, 1.7102 Steel	1.1200, 1.8159, 1.7102 Steel
	Spring, optional	1.4310 Stainless steel	1.4310 Stainless steel
55	Stud	1.1181 Steel	1.1181 Steel
56	Nut	1.0501 2H	1.0501 2H
57	Pin	1.4310 Stainless steel	1.4310 Stainless steel
60	Gasket	Graphite / 1.4401 Graphite / 316	Graphite / 1.4401 Graphite / 316
61	Ball	1.3541 Hardened stainless steel	1.3541 Hardened stainless steel
63	Countersunk screw	1.4401 Chrome steel	1.4401 Chrome steel

Please observe:

- LESER reserves the right to make changes.
- LESER may use higher quality materials without giving prior notice.
- Each component can be replaced by another material according to the customer's specification.
- All components exposed to pressure are highlighted in bold.

Balanced bellows design 546 – Level 1

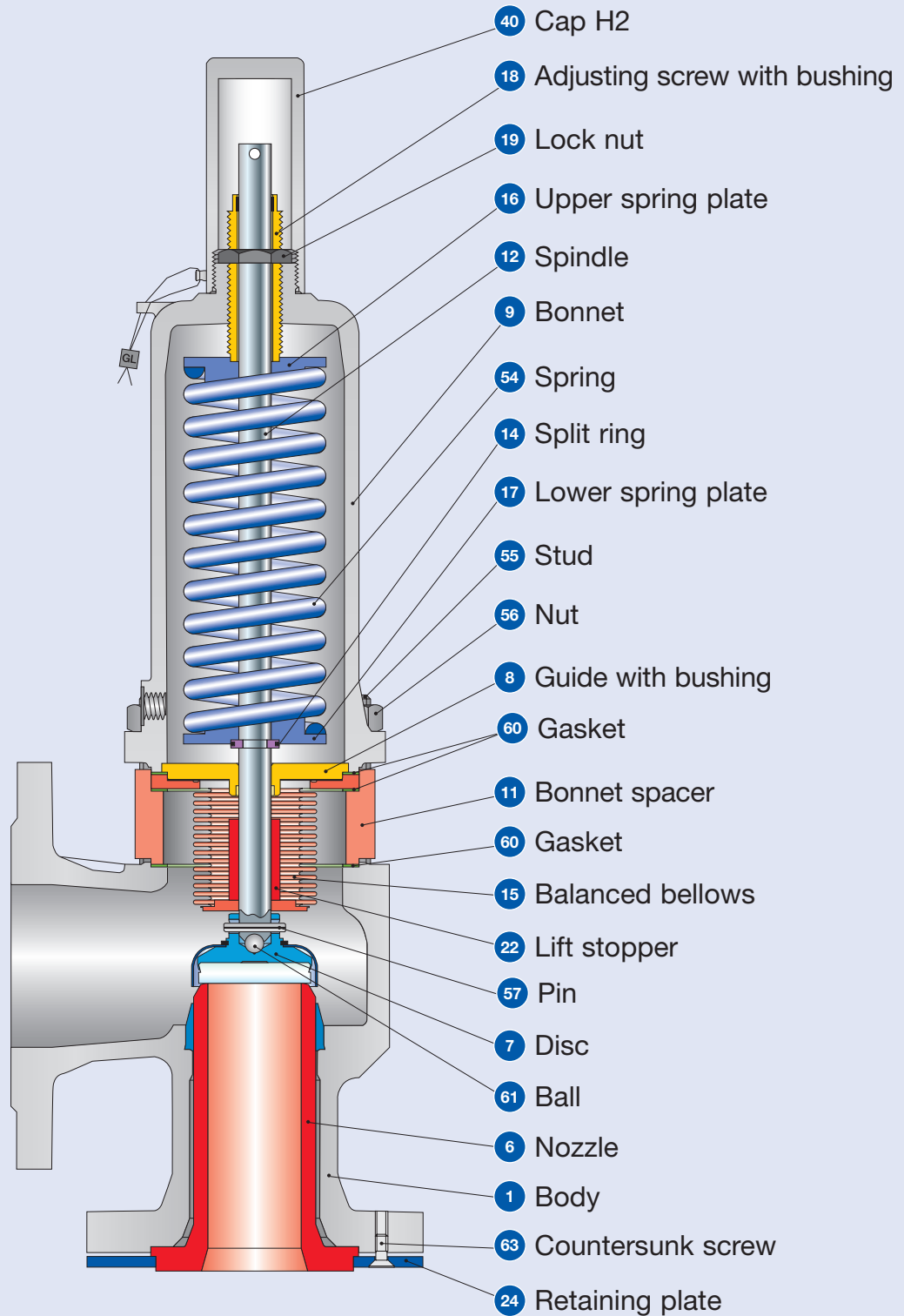

Balanced bellows design 546 – Level 1

Materials		Type 5462	Type 5465
1	Body	1.0619 SA 216 WCB	0.7043 Ductile Gr. 60-40-18
5	Nozzle	Virgin PTFE PTFE-TF	Virgin PTFE PTFE-TF
7	Disc	1.4404 / BOROFLOAT glass 316L / BOROFLOAT glass	1.4404 / BOROFLOAT glass 316L / BOROFLOAT glass
8	Guide	1.4404 Stainless steel	1.4404 Stainless steel
9	Bonnet	0.7040 Ductile Gr. 60-40-18	0.7040 Ductile Gr. 60-40-18
11	Bonnet spacer	1.4404 Stainless steel	1.4404 Stainless steel
12	Spindle	1.4404 Stainless steel	1.4404 Stainless steel
14	Split ring	1.4104 Chrome steel	1.4104 Chrome steel
15	Stainless steel bellows	1.4571 316Ti	1.4571 316Ti
16/17	Spring plate	1.0718 Steel	1.0718 Steel
18	Adjusting screw with bushing	1.4104 PTFE Chrome steel PTFE	1.4104 PTFE Chrome steel PTFE
19	Lock nut	1.4104 Chrome steel	1.4104 Chrome steel
22	Lift stopper	1.4404 316L	1.4404 316L
24	Retaining plate	1.0036 Steel	1.0036 Steel
40	Cap H2	1.0460 SA 105	1.0460 SA 105
54	Spring, standard	1.1200, 1.8159, 1.7102 Steel	1.1200, 1.8159, 1.7102 Steel
	Spring, optional	1.4310 Stainless steel	1.4310 Stainless steel
55	Stud	1.1181 Steel	1.1181 Steel
57	Pin	1.4310 Stainless steel	1.4310 Stainless steel
56	Nut	1.0501 2H	1.0501 2H
60	Gasket	Graphite / 1.4401 Graphite / 316	Graphite / 1.4401 Graphite / 316
61	Ball	1.3541 Hardened stainless steel	1.3541 Hardened stainless steel
63	Countersunk screw	1.4401 Chrome steel	1.4401 Chrome steel

Please observe:

- LESER reserves the right to make changes.
- LESER may use higher quality materials without giving prior notice.
- Each component can be replaced by another material according to the customer's specification.
- All components exposed to pressure are highlighted in bold.

PTFE bellows design 5466 – Level 2

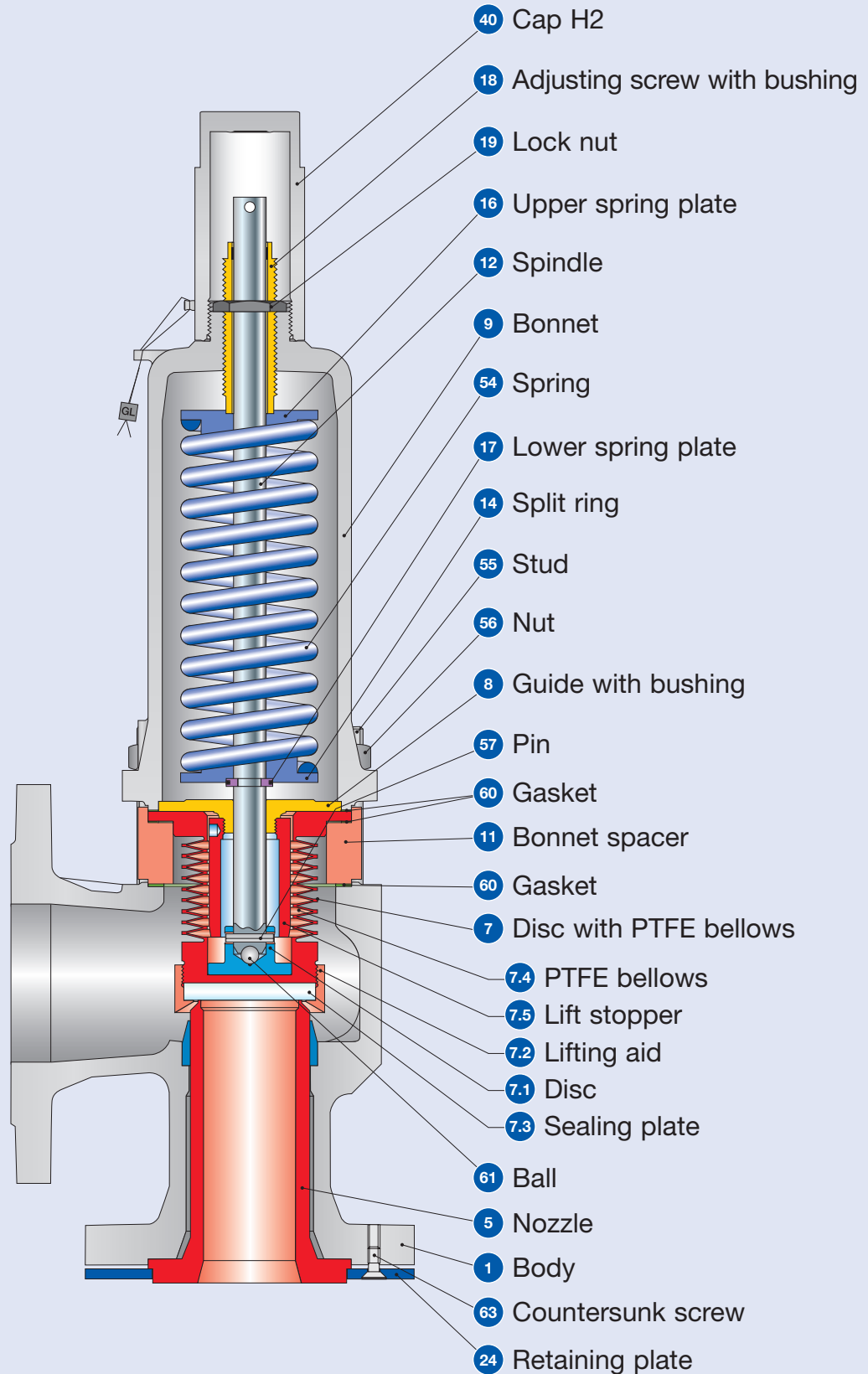

Type 5466

PTFE bellows design 5466 – Level 2

Materials		Type 5466
Item	Components	Type 5466
1	Body	1.0619 ¹⁾ SA 216 WCB
5	Nozzle	PTFE-TFM + 25 % carbon
7	Disc with PTFE bellows	1.4404 / PTFE 1.4404 / PTFE
7.1	Disc	1.4404 316L
7.2	Lifting aid	PTFE-TFM + 25% glass
7.3	Sealing plate	PTFE-TFM + 25% carbon
7.4	PTFE bellows	PTFE-TFM
7.5	Lift stopper	1.4404 316L
8	Guide	1.4404 Stainless steel
9	Bonnet	0.7043 Ductile Gr. 60-40-18
11	Bonnet spacer	1.4404 316L
12	Spindle	1.4404 Stainless steel
14	Split ring	1.4104 Chrome steel
16/17	Spring plate	1.0718 Steel
18	Adjusting screw with bushing	1.4104 PTFE Chrome steel PTFE
19	Lock nut	1.4104 Chrome steel
24	Retaining plate	1.0036 Steel
40	Cap H2	1.0460 SA 105
54	Spring, standard	1.1200, 1.8159, 1.7102 Steel
	Spring, optional	1.4310 Stainless steel
55	Stud	1.4401 B8M
56	Nut	1.4401 8M
57	Pin	1.4310 Stainless steel
60	Gasket	Graphite / 1.4401 Graphite / 316
61	Ball	1.3541 Hardened stainless steel
63	Countersunk screw	1.4401 Chrome steel

¹⁾ With SikaCor Zinc ZS coating in the outlet area.

Please observe:

– LESER reserves the right to make changes. LESER may use higher quality materials without giving prior notice. Each component can be replaced by another material according to the customer's specification. All components exposed to pressure are highlighted in bold.

How to order – Article numbers

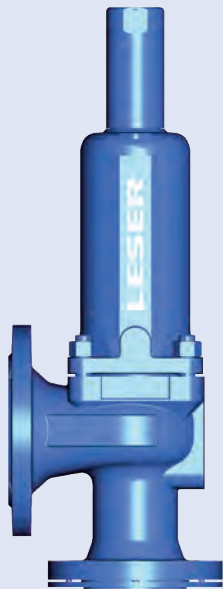

Cap H2
Closed bonnet
Conventional design

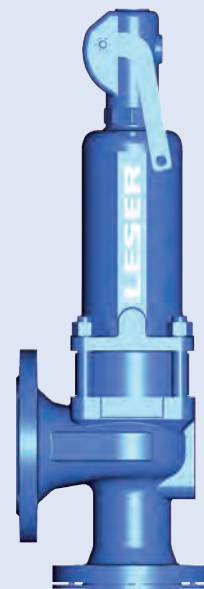

Type 546
Packed lever H4
Closed bonnet
Balanced bellows design

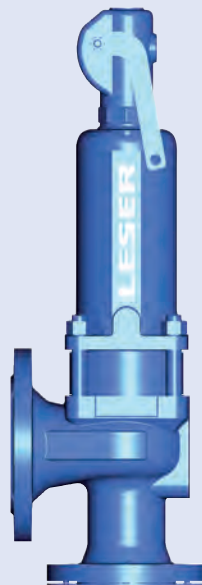

Type 5466
Packed lever H4
Closed bonnet
PTFE bellows design

Article numbers

Type 546								
DN _i		25	40	50	65	80	100	
DN _o		40	65	80	100	125	150	
Valve size		1" x 1 1/2"	1 1/2" x 2 1/2"	2" x 3"	2 1/2" x 4"	3" x 5"	4" x 6"	
Actual Orifice diameter d ₀ [mm]		23	37	46	60	72	87	
Actual Orifice area A ₀ [mm ²]		416	1075	1662	2827	4072	5945	
Body material: 0.7043 (Ductile Gr. 60-40-18)								
PTFE nozzle								
Bonnet closed	H2	Art.-No. 5465.	-	3722	-	3742	-	3762
	H4	Art.-No. 5465.	-	3724	-	3744	-	3764
Body material: 1.0619 (WCB)								
PTFE nozzle								
Bonnet closed	H2	Art.-No. 5462.	3802	-	3812	-	3822	-
	H4	Art.-No. 5462.	3804	-	3814	-	3824	-

Type 5466							
DN _i		25	50				
DN _o		40	80				
Valve size		1" x 1 1/2"	2" x 3"				
Actual Orifice diameter d ₀ [mm]		23	46				
Actual Orifice area A ₀ [mm ²]		416	1662				
Body material: 1.0619 (WCB)							
PTFE-carbon nozzle							
Bonnet closed	H2	Art.-No. 5466.	3832	3842			
	H4	Art.-No. 5466.	3834	3844			

Dimensions and weights

Metric Units							
	DN _i	25	40	50	65	80	100
	DN _o	40	65	80	100	125	150
	Valve size	1" x 1 1/2"	1 1/2" x 2 1/2"	2" x 3"	2 1/2" x 4"	3" x 5"	4" x 6"
	Actual Orifice diameter d ₀ [mm]	23	37	46	60	72	87
	Actual Orifice area A ₀ [mm ²]	416	1075	1662	2827	4072	5945
Weight [kg]		9	19	22	27	39	55
	with bellows	10	20	24	31	43	63
Centre to face [mm]	Inlet a	105	140	150	170	195	220
	Outlet b	100	115	120	140	160	180
Height (H4) [mm]	Standard H max.	327	486	538	565	743	796
	Bellows H max.	395	605	590	615	840	885
Body material: 0.7043 (Ductile Gr. 60-40-18)							
DIN Flange¹⁾	Inlet						PN 16
	Outlet						PN 16
Body material: 1.0619 (WCB)							
DIN Flange¹⁾	Inlet						PN 16
	Outlet						PN 16

¹⁾ Standard flange class For other flange drillings, see page 48.

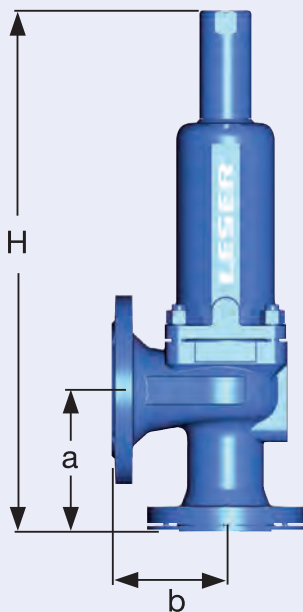

Conventional design

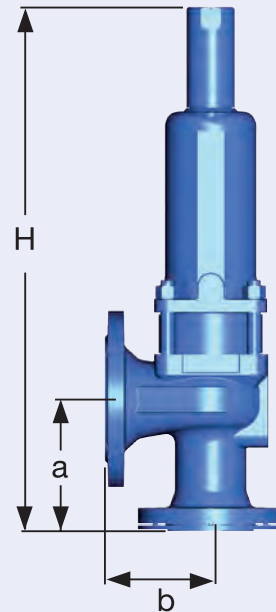

Balanced bellows design

Pressure temperature ratings

Metric Units							
	DN _E	25	40	50	65	80	100
	DN _A	40	65	80	100	125	150
	Valve size	1" x 1 1/2"	1 1/2" x 2 1/2"	2" x 3"	2 1/2" x 4"	3" x 5"	4" x 6"
	Actual Orifice diameter d ₀ [mm]	23	37	46	60	72	87
	Actual Orifice area A ₀ [mm ²]	416	1075	1662	2827	4072	5945
Body material: 0.7043 (Ductile Gr. 60-40-18)				Type 5465			
DIN Flange	Inlet	–	PN 16	–	PN 16	–	PN 16
	Outlet	–	PN 16	–	PN 16	–	PN 16
Min. set pressure	p [bar _g] S/G/L	–	0,5	–	0,5	–	0,5
Max. set pressure	p [bar _g] S/G/L	–	10	–	10	–	10
Temperature acc. to DIN EN	min. [°C]	–	-60	–	-60	–	-60
	max. [°C]	–	+200	–	+200	–	+200
Body material: 1.0619 (WCB)				Type 5462			
DIN Flange	Inlet	PN 16	–	PN 16	–	PN 16	–
	Outlet	PN 16	–	PN 16	–	PN 16	–
Min. set pressure	p [bar _g] S/G/L	0,5	–	0,5	–	0,5	–
Max. set pressure	p [bar _g] S/G/L	10	–	10	–	10	–
Temperature acc. to DIN EN	min. [°C]	-85	–	-85	–	-85	–
	max. [°C]	+200	–	+200	–	+200	–
Body material: 1.0619 (WCB)				Type 5466			
DIN Flange	Inlet	PN 16	–	PN 16	–	–	–
	Outlet	PN 16	–	PN 16	–	–	–
Min. set pressure	p [bar _g] S/G/L	0,1	–	0,1	–	–	–
Max. set pressure	p [bar _g] S/G/L	10	–	10	–	–	–
Temperature acc. to DIN EN	min. [°C]	-85	–	-85	–	–	–
	max. [°C]	+200	–	+200	–	–	–

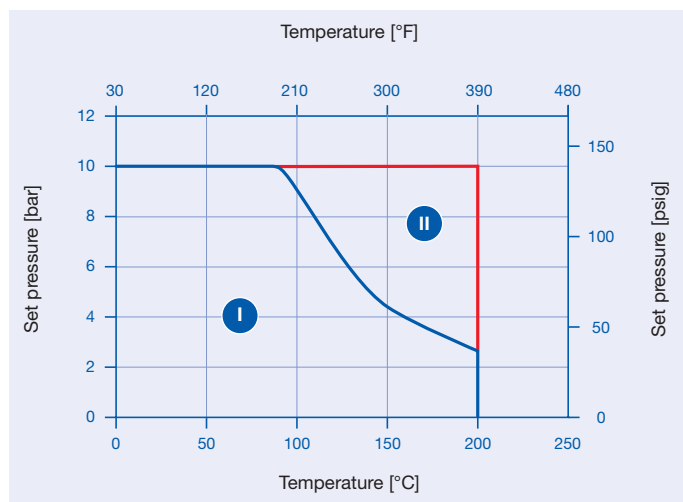

Pressure temperature ratings

The pressure/temperature functional ranges of Type 546 and Type 5466 are dependent on the PTFE components in the safety valve. The chart shows the application ranges for:

- I Standard design.
Type 5466 can be used only in the area I.
- II For Type 546 nickel-base alloys must be used for nozzle and sealing plate.

Order information – Flange drillings

Flange drillings								
	DN _i	25	40	50	65	80	100	
	DN _o	40	65	80	100	125	150	
	Valve size	1" x 1 1/2"	1 1/2" x 2 1/2"	2" x 3"	2 1/2" x 4"	3" x 5"	4" x 6"	
	Actual Orifice diameter d ₀ [mm]	23	37	46	60	72	87	
	Actual Orifice area A ₀ [mm ²]	416	1075	1662	2827	4072	5945	
Body material: 0.7043 (Ductile Gr. 60-40-18) Type 5465								
Inlet	DIN EN 1092	PN 10	–	H44	–	H44	–	H44
		PN 16	–	*	–	*	–	*
	ASME B16.5	CL 150	–	(H64)	–	(H64)	–	(H64)
Outlet	DIN EN 1092	PN 10	–	H50	–	H50	–	H50
		PN 16	–	*	–	*	–	*
	ASME B16.5	CL 150	–	(H79)	–	(H79)	–	(H79)
Body material: 1.0619 (WCB) Type 5462								
Inlet	DIN EN 1092	PN 10	H44	–	H44	–	H44	–
		PN 16	*	–	*	–	*	–
	ASME B16.5	CL 150	(H64)	–	(H64)	–	(H64)	–
Outlet	DIN EN 1092	PN 10	H50	–	H50	–	H50	–
		PN 16	*	–	*	–	*	–
	ASME B16.5	CL 150	(H79)	–	(H79)	–	(H79)	–
Body material: 1.0619 (WCB) Type 5466								
Inlet	DIN EN 1092	PN 10	H44	–	H44	–	–	–
		PN 16	*	–	*	–	–	–
	ASME B16.5	CL 150	(H64)	–	(H64)	–	–	–
Outlet	DIN EN 1092	PN 10	H50	–	H50	–	–	–
		PN 16	*	–	*	–	–	–
	ASME B16.5	CL 150	(H79)	–	(H79)	–	–	–

Definitions as well as sign and symbols please refer to page 15.

Order information – Spare parts

Spare parts							
	DN _i	25	40	50	65	80	100
	DN _o	40	65	80	100	125	150
	Valve size	1" x 1 1/2"	1 1/2" x 2 1/2"	2" x 3"	2 1/2" x 4"	3" x 5"	4" x 6"
	Actual Orifice diameter d ₀ [mm]	23	37	46	60	72	87
	Actual Orifice area A ₀ [mm ²]	416	1075	1662	2827	4072	5945
Material no. / Art.-No.							
Nozzle (Item 5): Type 5462 + 5465	PTFE-TF	206.4659.0000	206.4759.0000	206.4859.0000	206.4959.0000	206.5059.0000	206.5159.0000
Nozzle (Item 5): Type 5466	PTFE-TFM + 25% carbon	207.1869.0000	–	207.1769.0000	–	–	–
Disc (Item 7): Type 546 Detachable lifting aid 1.4404 with sealing plate (BOROFLOAT glass)		220.2949.0000	220.3149.0000	220.3049.0000	220.3249.0000	220.3349.0000	220.3449.0000
Disc (Item 7): Type 5466 Detachable lifting aid 1.4404 with sealing plate (PTFE-TFM + 25% carbon)		220.3559.0000	–	220.3659.0000	–	–	–
Bellows (Item 15): Type 546	1.4571	400.2949.0000	400.3049.0000	400.3149.0000	400.3249.0000	400.3349.0000	400.3449.0000
Bellows conversion kit ¹⁾	1.4571	5021.1081	–	5021.1082	–	–	–
Bellows (Item. 7): Type 5466	PTFE-TFM	224.3059.0000	–	224.1759.0000	–	–	–
Gasket (Item 7.3) Body / Bonnet	Graphite + 1.4401	500.0607.0000	500.1007.0000	500.1207.0000	500.1207.0000	500.1607.0000	500.1907.0000
Option code L68	Gylon (PTFE compliance)	500.0605.0000	500.1005.0000	500.1205.0000	500.1205.0000	500.1605.0000	500.1905.0000
Ball (Item 61)	Ball Ø [mm]	6	9	9	9	12	12
	1.4401	510.0104.0000	510.0204.0000	510.0204.0000	510.0204.0000	510.0304.0000	510.0304.0000
Split ring (Item 14)	Spindle Ø [mm]	12	16	16	16	20	24
	1.4404	251.0149.0000	251.0249.0000	251.0249.0000	251.0249.0000	251.0349.0000	251.0449.0000
Roll pin (Item 57)	1.4310	480.0705.0000	480.2305.0000	480.2305.0000	480.2305.0000	480.1005.0000	480.1005.0000

¹⁾ Pressure range, see page 47.

A conversion kit includes the following components:

Item	Components	No.
8	Guide with bushing	1
11	Bonnet spacer	1
12	Spindle	1
15	Bellows	1
55	Stud	4
60	Gasket	3
–	Installation instruction WI_3037.05	1

Refer to page 40.

Available options

For further information, refer to "Accessories and options", page 61

Type 546, Type 5466

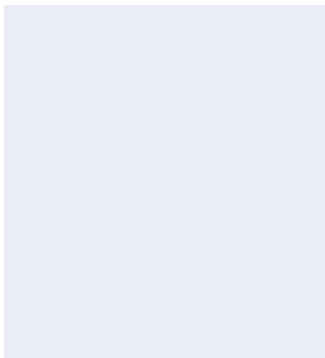
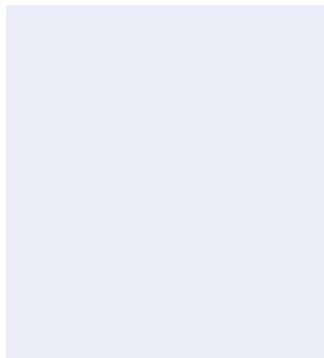
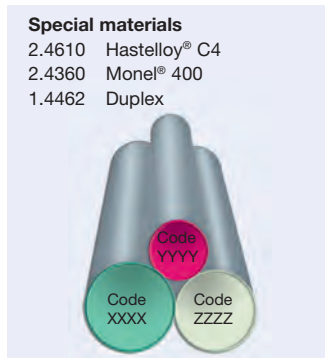
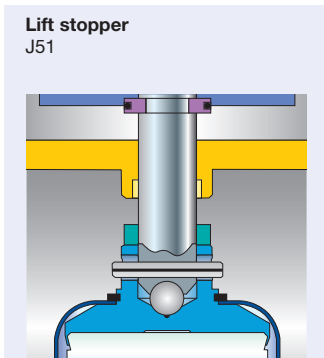
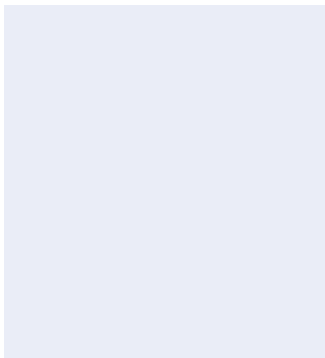
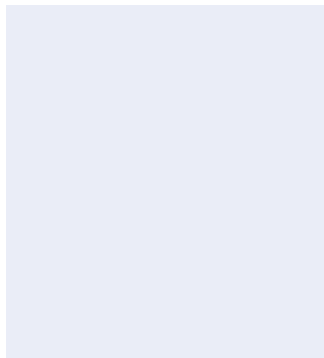
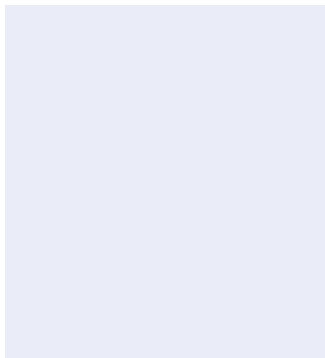
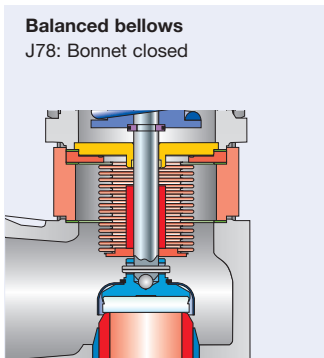
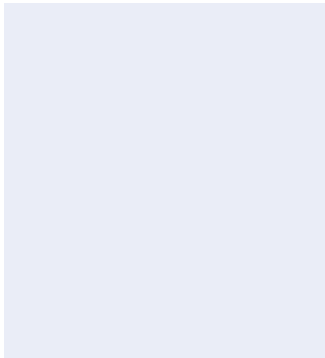
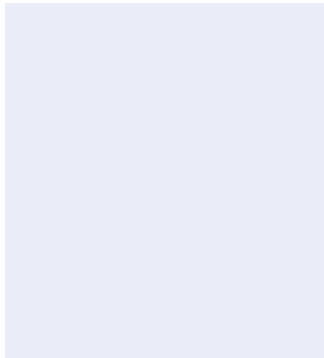
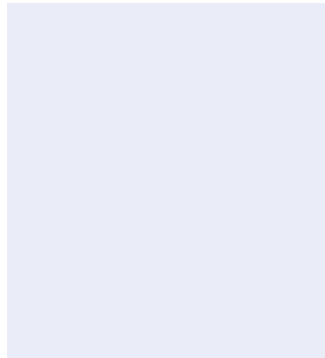
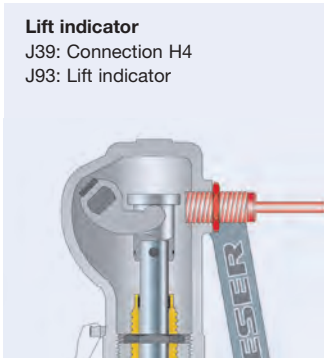
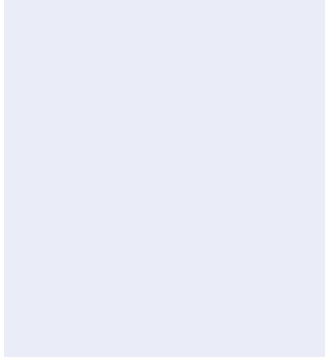
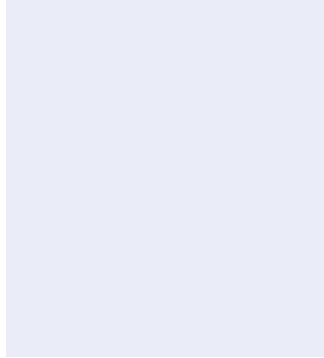
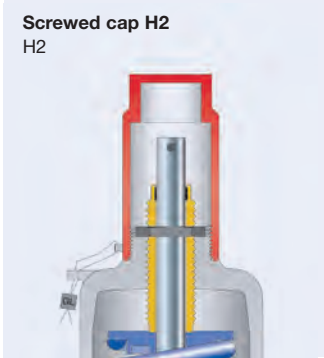

Approvals

Approvals							
	DN _i	25	40	50	65	80	100
	DN _o	40	65	80	100	125	150
	Valve size	1" x 1 1/2"	1 1/2" x 2 1/2"	2" x 3"	2 1/2" x 4"	3" x 5"	4" x 6"
	Actual Orifice diameter d ₀ [mm]	23	37	46	60	72	87
	Actual Orifice area A ₀ [mm ²]	416	1075	1662	2827	4072	5945
Europe				Coefficient of discharge K _{dr}			
DIN EN ISO 4126-1	Approval no.	072020111Z0008/0/19					
	Type 5462 + 5465 S/G	0,73	0,68	0,68	0,68	0,64	0,64
	5466 S/G	0,76	–	0,69	–	–	–
	Type 5462 + 5465 L	0,46	0,43	0,43	0,43	0,40	0,40
	5466 L	0,51	–	0,46	–	–	–
Germany				Coefficient of discharge C _w			
AD 2000-Merkblatt A2	Approval no.	TÜV SV 496					
	Type 5462 + 5465 S/G	0,73	0,68	0,68	0,68	0,64	0,64
	5466 S/G	0,76	–	0,69	–	–	–
	Type 5462 + 5465 L	0,46	0,43	0,43	0,43	0,40	0,40
	5466 L	0,51	–	0,46	–	–	–
China				Coefficient of discharge C _w			
AQSIQ	Approval no.	For current approval no. see www.leser.com					
	Type 546 S/G	0,73	0,68	0,68	0,68	0,64	0,64
	Type 546 L	0,46	0,43	0,43	0,43	0,40	0,40
Eurasian Custom Union				Coefficient of discharge C _w			
EAC	Approval no.	For current approval no. see www.leser.com					
	Type 546 S/G	0,73	0,68	0,68	0,68	0,64	0,64
	Type 546 L	0,46	0,43	0,43	0,43	0,40	0,40
Classification societies							
On request							

Type 546 – Capacities acc. to AD 2000-Merkblatt A2

Calculation of the capacity for steam, air and water acc. to. AD 2000-Merkblatt A2 with 10% overpressure at 0 °C and 1013 mbar (air) or alternatively 20 °C (water). Capacities at 1 bar and lower are calculated at 0,1 bar overpressure.

Metric units		AD 2000-Merkblatt A2																	
		Steam						Air						Water					
DN _i	25	40	50	65	80	100	25	40	50	65	80	100	25	40	50	65	80	100	
DN _o	40	65	80	100	125	150	40	65	80	100	125	150	40	65	80	100	125	150	
Actual Orifice diameter d ₀ [mm]	23	37	46	60	72	87	23	37	46	60	72	87	23	37	46	60	72	87	
Actual Orifice area A ₀ [mm ²]	416	1075	1662	2827	4072	5945	416	1075	1662	2827	4072	5945	416	1075	1662	2827	4072	5945	
LEO _{S/G/L} *) [inch ²]	0,482	1,162	1,797	3,057	4,143	6,048	0,482	1,162	1,797	3,057	4,143	6,048	0,304	0,775	1,136	1,933	2,589	3,780	
Set pressure	Capacity [kg/h]						Capacity [m ³ /h]						Capacity [10 ³ kg/h]						
0,5	250	615	951	951	2110	3081	293	722	1116	1899	2477	3616	7,53	18,22	28,20	47,90	64,20	93,90	
0,6	272	668	1033	1033	2303	3363	320	788	1218	2072	2715	3964	8,13	19,67	30,40	51,70	69,30	101,2	
0,7	292	717	1108	1108	2480	3621	346	849	1312	2231	2935	4286	8,69	21,03	32,50	55,30	74,10	108,2	
0,8	311	762	1178	1178	2646	3863	369	905	1399	2380	3142	4587	9,22	22,31	34,50	58,70	78,60	114,7	
0,9	330	807	1247	1247	2809	4101	392	960	1484	2524	3341	4878	9,72	23,52	36,30	61,80	82,80	120,9	
1,0	348	851	1315	1315	2969	4335	415	1014	1567	2666	3538	5166	10,2	24,7	38,1	64,9	86,9	126,8	
1,1	368	899	1389	1389	3143	4589	439	1073	1658	2820	3752	5478	10,7	25,9	40,0	68,0	91,1	133,0	
1,2	388	946	1463	1463	3317	4843	464	1131	1749	2974	3965	5790	11,2	27,0	41,8	71,0	95,2	139,0	
1,3	408	993	1535	1535	3488	5092	488	1189	1838	3127	4806	6098	11,6	28,1	43,5	73,9	99,1	144,6	
1,4	428	1040	1607	1607	3658	5341	513	1247	1928	3279	4387	6406	12,7	29,2	45,1	76,7	103,0	150,1	
1,5	447	1086	1679	1679	3828	5589	537	1305	2017	3431	4597	6713	12,5	30,2	46,7	79,4	106,0	155,4	
1,6	467	1133	1751	1751	3996	5835	561	1362	2105	3581	4806	7017	12,9	31,2	48,2	82,0	110,0	160,5	
1,7	486	1179	1822	1822	4164	6079	585	1419	2194	3731	5014	7320	13,3	32,2	49,7	84,6	113,0	165,4	
1,8	505	1224	1892	1892	4329	6321	609	1476	2281	3881	5220	7621	13,7	33,1	51,1	87,0	117,0	170,2	
1,9	524	1270	1962	1962	4495	6563	633	1533	2369	4030	5426	7923	14,1	34,0	52,5	89,4	120,0	174,8	
2,0	543	1315	2033	2033	4661	6805	657	1589	2457	4179	5633	8225	14,4	34,9	53,9	91,7	123,0	179,4	
2,1	562	1360	2102	2102	4825	7044	680	1646	2544	4328	5838	8524	14,8	35,7	55,2	94,0	126,0	183,8	
2,2	581	1405	2172	2172	4989	7284	704	1702	2631	4476	6043	8823	15,1	36,6	56,5	96,2	129,0	188,1	
2,3	600	1450	2241	2241	5152	7522	728	1758	2718	4624	6247	9121	15,5	37,4	57,8	98,4	132,0	192,4	
2,4	619	1495	2310	2310	5315	7760	751	1814	2804	4771	6452	9420	15,8	38,2	59,1	100,5	135,0	196,5	
2,5	638	1539	2379	2379	5477	7997	775	1870	2891	4918	6655	9717	16,1	39,0	60,3	102,5	137,0	200,6	
2,6	657	1584	2448	2448	5639	8233	798	1926	2977	5065	6858	10013	16,4	39,8	61,5	104,6	140,0	204,5	
2,7	675	1628	2517	2517	5801	8470	822	1982	3064	5212	7062	10311	16,8	40,5	62,6	106,6	143,0	208,4	
2,8	694	1672	2585	2585	5960	8701	845	2038	3149	5358	7262	10602	17,1	41,3	63,8	108,5	145,0	212,3	
2,9	712	1716	2652	2652	6144	8927	868	2092	3234	5502	7457	10887	17,4	42,1	64,9	110,4	148,0	216,0	
3	730	1759	2719	2719	6269	9153	891	2147	3319	5646	7652	11172	17,7	42,7	66,0	112,3	150,0	219,7	
4							1118	2695	4165	7086	9603	14021	20,4	49,3	76,2	129,7	174,0	254,0	
5							1345	3242	5011	8526	11555	16870	22,8	55,2	85,2	145,0	194,0	284,0	
6							1572	3790	5857	9965	13506	19719	25,0	60,4	93,4	158,9	213,0	311,0	
7							1799	4337	6704	11405	15457	22569	27,0	65,3	100,9	171,6	230,0	336,0	
8							2026	4884	7550	12845	17409	25418	28,8	69,8	107,8	183,4	246,0	359,0	
9							2253	5432	8396	14285	19360	28267	30,6	74,0	114,4	194,6	261,0	381,0	
10							2481	5980	9242	15725	21312	31116	32,2	78,0	120,6	205,1	275,0	402,0	

*) LEO_{S/G/L} = LESER Effective Orifice steam/gases/liquids see page 18/19. "How to use" capacity tables, see page 16.

Type 5466 – Capacities acc. to AD 2000-Merkblatt A2

Calculation of the capacity for steam, air and water acc to. AD 2000-Merkblatt A2 with 10% overpressure at 0 °C and 1013 mbar (air) or alternatively 20 °C (water). Capacities at 1 bar and lower are calculated at 0,1 bar overpressure.

Metric units		AD 2000-Merkblatt A2					
		Steam		Air		Water	
DN _E		25	50	25	50	25	50
DN _A		40	80	40	80	40	80
Actual Orifice diameter d ₀ [mm]		23	46	23	46	23	46
Actual Orifice area A ₀ [mm ²]		416	1662	416	1662	416	1662
LEO _{S/G/L} ^{*)} [inch ²]		0,482	1,797	0,482	1,797	0,304	1,136
Set pressure		Capacity [kg/h]		Capacity [m ³ /h]		Capacity [10 ³ kg/h]	
0,1		133	513	153	590	4,35	16,30
0,2		168	645	194	747	5,32	19,90
0,3		198	759	231	883	6,15	23,00
0,4		225	860	263	1005	6,87	25,70
0,5		250	951	293	1116	7,53	28,20
0,6		272	1033	320	1218	8,13	30,40
0,7		292	1108	346	1312	8,69	32,50
0,8		311	1178	369	1399	9,22	34,50
0,9		330	1247	392	1484	9,72	36,30
1,0		348	1315	415	1567	10,2	38,1
1,1		368	1389	439	1658	10,7	40,0
1,2		388	1463	464	1749	11,2	41,8
1,3		408	1535	488	1838	11,6	43,5
1,4		428	1607	513	1928	12,7	45,1
1,5		447	1679	537	2017	12,5	46,7
1,6		467	1751	561	2105	12,9	48,2
1,7		486	1822	585	2194	13,3	49,7
1,8		505	1892	609	2281	13,7	51,1
1,9		524	1962	633	2369	14,1	52,5
2,0		543	2033	657	2457	14,4	53,9
2,1		562	2102	680	2544	14,8	55,2
2,2		581	2172	704	2631	15,1	56,5
2,3		600	2241	728	2718	15,5	57,8
2,4		619	2310	751	2804	15,8	59,1
2,5		638	2379	775	2891	16,1	60,3
2,6		657	2448	798	2977	16,4	61,5
2,7		675	2517	822	3064	16,8	62,6
2,8		694	2585	845	3149	17,1	63,8
2,9		712	2652	868	3234	17,4	64,9
3,0		730	2719	891	3319	17,7	66,0
4,0				1118	4165	20,4	76,2
5,0				1345	5011	22,8	85,2
6,0				1572	5857	25,0	93,4
7,0				1799	6704	27,0	100,9
8,0				2026	7550	28,8	107,8
9,0				2253	8396	30,6	114,4
10				2481	9242	32,2	120,6

Application not possible due to the pressure and temperature ranges of the PTFE nozzle.

*) LEO_{S/G/L} = LESER Effective Orifice steam/gases/liquids see page 18/19. "How to use" capacity tables, see page 16.

Type 5466

Determination of coefficient of discharge in case of lift restriction or back pressure

Legend

h	= Lift [mm]
d_0	= Actual Orifice diameter [mm] of the selected safety valve, see „Article numbers“ table
h/d_0	= Ratio of lift / narrowest flow diameter
p_{a0}	= Back pressure [bar _a]
p_0	= Set pressure [bar _a]
p_{a0}/p_0	= Ratio of absolute back pressure / absolute set pressure
K_{dr}	= Coefficient of discharge acc. to DIN EN ISO 4126-1
α_w	= Coefficient of discharge acc. to AD 2000-Merkblatt A2
K_b	= Correction for back pressure acc. to API 520 Section 3.3

Type 546

Diagram for evaluation of ratio of lift / flow diameter (h/d_0) in reference to the coefficient of discharge (K_{dr}/α_w)

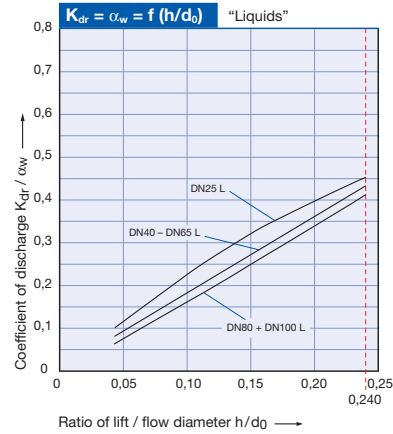
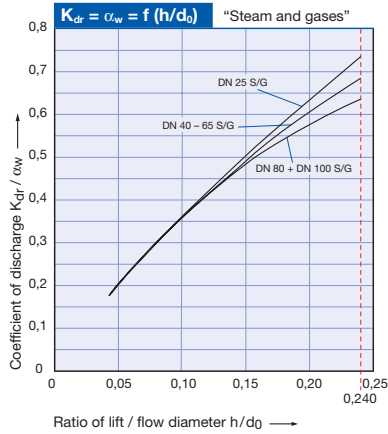

Type 5466

Diagram for evaluation of ratio of lift / flow diameter (h/d_0) in reference to the coefficient of discharge (K_{dr}/α_w)

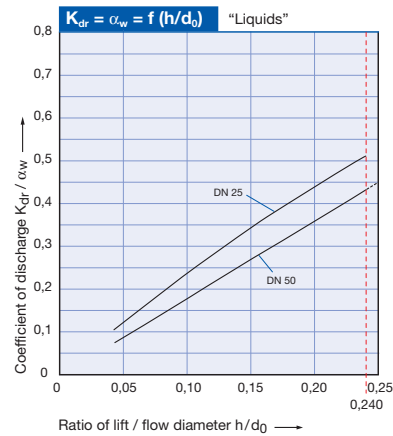
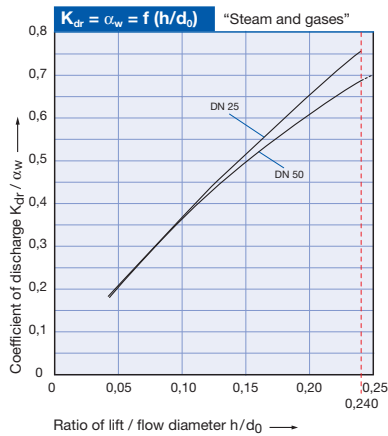

Type 546

Diagram for evaluation of the coefficient of discharge (K_{dr}/α_w) or K_b in reference with the ratio of absolute back pressure/set pressure (p_{a0}/p_0)

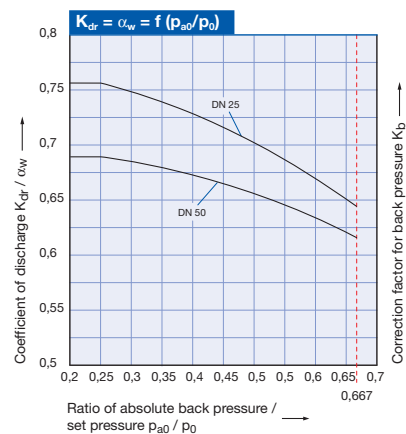
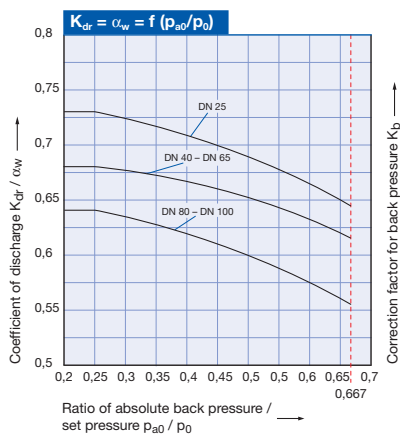

Type 449

Flanged Safety Relief Valve
– spring loaded

Contents	Page
Application range	56
Protective gas flushing design	56
How to order	
• Article numbers	57
• Dimensions and weights	58
• Specification Sheet	59



Type 449
Screwed cap H2
Bonnet closed

Application range

Type 449 is a type-tested safety valve for protection against toxic media, often also in connection with corrosion.

Type 449 is characterised by:

- A duct system for flushing with protective gas.
- Balanced bellows for back pressure compensation and protection of the bonnet space.

- Manufacture of the body components as well as most inner components of rod or forged material in order to realise customer-specific material requirements, nominal pressure ratings, flange drillings and facings, and centre to face dimensions. Please use the "Specification Sheet" on page 59 and 60 for this.

Naturally, LESER will advise you on the configuration of Type 449 for your application.

Protective gas flushing design

If highly toxic media form in systems, then suitable measures must be taken so that neither people nor the environment are endangered by that media.

One way to avoid any endangering is the installation of a duct system for flushing protective gas.

Here, a duct system is built around all safety valve components that carry highly toxic media. A protective gas flows through this duct system, which has the following task:

- Neutralisation of the highly toxic medium in the event of a leak.
- Residue from the neutralisation reaction is detected by detectors in the protective gas duct system and communicated to the control room where any necessary steps can be initiated.

Type 449 can be directly integrated into these duct systems. Through the appropriate connection flange and a special duct system, the protective gas is channelled from the inlet to the outlet side. The duct system design ensures that all possible leakage points are contacted by the protective gas.

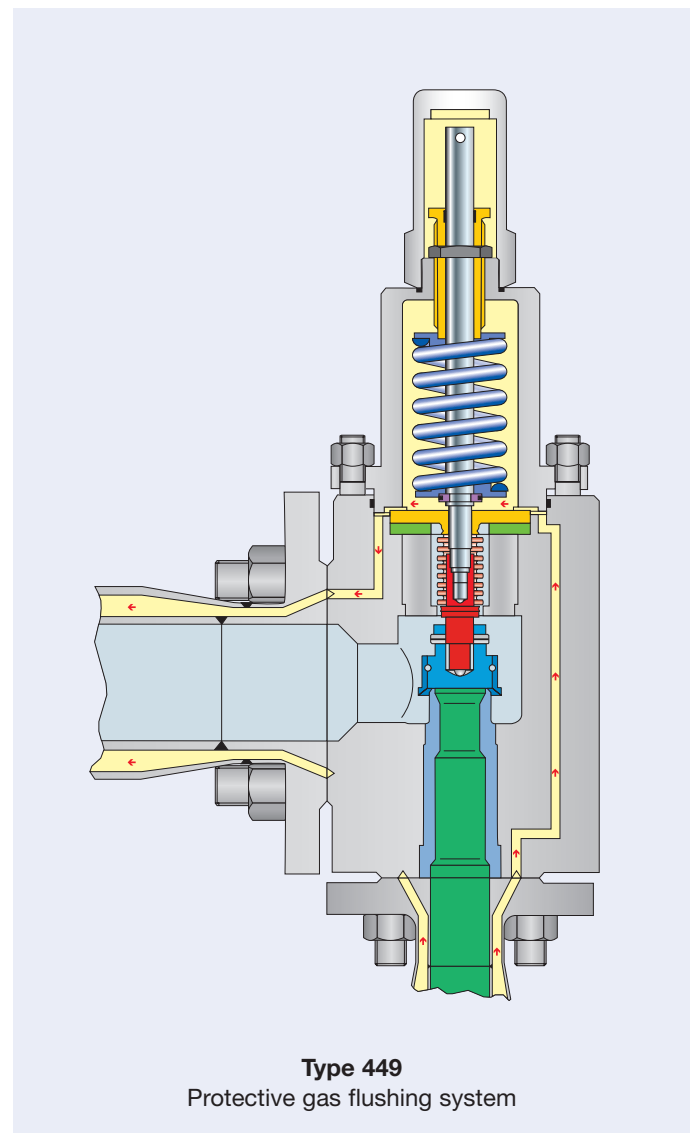

Article numbers

Article numbers						
	DN _i		25	50	80	100
	DN _o		50	80	100	150
	Valve size		1" x 2"	2" x 3"	3" x 4"	4" x 6"
	Actual Orifice diameter d ₀ [mm]		23	46	60	92
	Actual Orifice area A ₀ [mm ²]		416	1662	2827	6648
Bonnet closed	H2	Art.-No. 4494.	3362	3372	3382	3392
	H4	Art.-No. 4494.	3364	3374	3384	3394

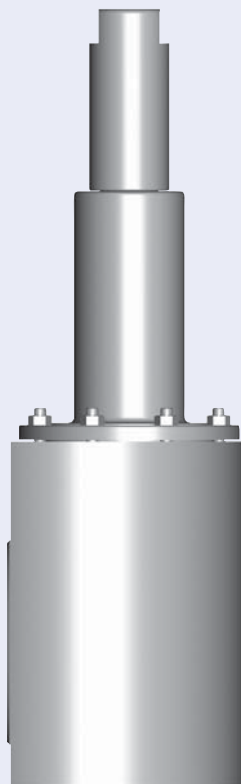

Type 449
Cap H2
Bonnet closed
Conventional design

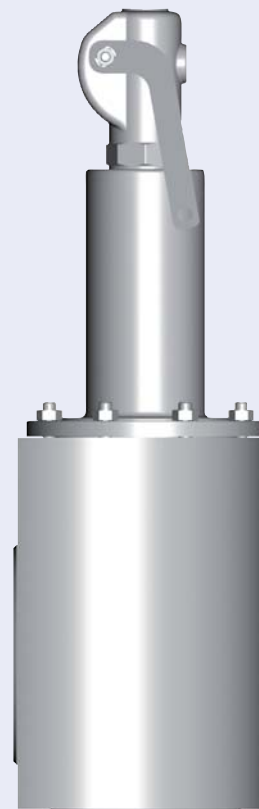

Type 449
Packed lever H4
Bonnet closed
Conventional design

Dimensions and weights

Metric units		25	50	80	100
	DN _i	25	50	80	100
	DN _o	50	80	100	150
	Valve size	1" x 2"	2" x 3"	3" x 4"	4" x 6"
	Actual Orifice diameter d ₀ [mm]	23	46	60	92
	Actual Orifice area A ₀ [mm ²]	415	1662	2827	6648

Weight [kg]		Specifications dependent on customer specification			
Centre to face [mm]	Inlet a				
	Outlet b				
Height (H4) [mm]	H max.				
DIN Flange	PN Inlet	Specifications dependent on customer specification			
	PN Outlet				
ASME B16.5 Flange	Class Inlet	Specifications dependent on customer specification			
	Class Outlet				

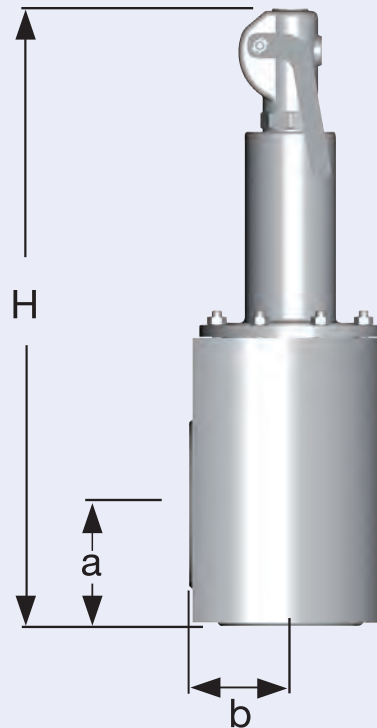

Conventional design

How to Order – Specification Sheet

Please fax your inquiry to: **+49 40 25165-500**
or contact your local LESER-Representative - refer to www.leser.com

Company:	Phone:	Fax:	E-mail:
Name:	Date:	Sheet 1 of:	Rev.:
Contract/Reference:	Spec.-No.:	Rev.:	Request:

General	
1	Quantity: _____ of _____
2	Item-no.: _____
3	Tag-no.: _____
4	Service: _____
5	Line no./Vessel no.: _____
6	VALVESTAR calc. Area: _____
7	Selected area: _____
8	Orifice designation: _____

Service conditions	
9	Fluid and state _____
10	Oper. pressure _____ bar
11	Set pressure _____ bar
12	Oper. temperature _____ °C
13	Rel. temperature _____ °C
14	Back pressure total _____ bar
15	Allowable overpress. _____ %
16	Inert gas pressure _____ bar

Connections			
17	Inlet	Size _____	DN
18		Pressure rating _____	PN
19		Type of facing _____	
20		Centre to face a _____	mm
21	Outlet	Size _____	DN
22		Pressure rating _____	PN
23		Type of facing _____	
24		Centre to face b _____	mm

Duct System	
25	Duct system _____ yes <input type="checkbox"/> no <input type="checkbox"/>
26	Inert gas pressure _____ bar
27	Jacketed flange comply with _____
28	<input type="checkbox"/> BAYER Standard 594 edition 02.2003
29	<input type="checkbox"/> Other: _____

Additional design data	

Required approvals	

How to Order – Specification Sheet

Please fax your inquiry to: **+49 40 25165-500**
or contact your local LESER-Representative - refer to www.leser.com

Material Specification

	Item	Description	Qty.	Material specification	MTC
	30	1 Body	1		* <input type="checkbox"/>
	31	5 Nozzle	1		* <input type="checkbox"/>
	32	7 Disc, metal to metal	1		* <input type="checkbox"/>
	33	8 Guide	1		- -
	34	9 Bonnet	1		* <input type="checkbox"/>
	35	12 Spindle	1		- -
	36	14 Split ring	2		* <input type="checkbox"/>
	37	15 Ballanced bellows	1		-
	38	16 Upper spring plate	1		- -
	39	17 Lower spring plate	1		- -
	40	18 Adjusting screw	1		- -
	41	19 Lock nut	1		- -
	42	22 Lift stopper	1		- -
	43	40 Cap H2	1		* <input type="checkbox"/>
	44	54 Spring	1		* <input type="checkbox"/>
	45	55 Stud	4		* <input type="checkbox"/>
	46	56 Nut	4		* <input type="checkbox"/>
	47	57 Pin	1		- -
	48	60 Gasket	1		- -
	49	61 Ball	1		- -
	50	63 O-ring	1		- -
51	75 O-ring	1		- -	

MTC: Material Test Certificate 3.1 acc. DIN EN 10204

* = Default is 3.1

- = Not available

= Editable is 3.2

Dimensions and weights

You receive the complete technical specification sheet together with the LESER order confirmation.

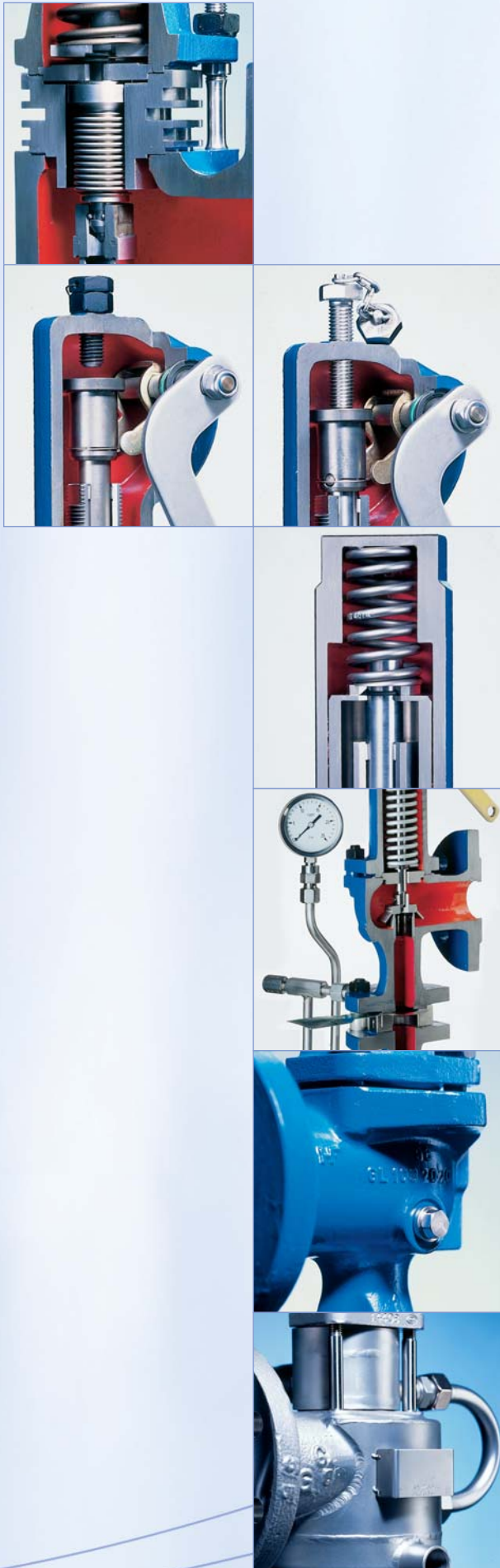

Accessories and Options

Contents

Page

Overview	62
Caps and levers	64
Bellows design	66
Sealing plate	68
Lift indicator	69
Lift restriction	70
FAQ	71

Overview

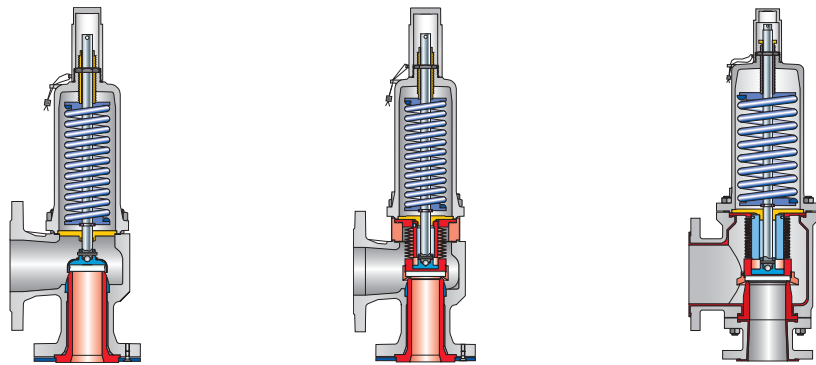

Options		546	5466	447
Body (Item 1)				
	Grounding connection	✓	✓	✓
	Drainage hole	✓	✓	–
Inlet body (Item 1)				
Lining	Virgin PTFE	–	–	*
	Electrically conductive PTFE	–	–	✓
Outlet body (Item 2)				
Lining	Virgin PTFE	–	–	*
	Electrically conductive PTFE	–	–	✓
Nozzle (Item 5)				
	PTFE-TFM + 25 % glass	–	–	*
	Electrically conductive PTFE	–	–	✓
	PTFE-TFM + 25 % carbon	–	*	–
	As per customer specification, e.g. Hastelloy®	✓	✓	✓
Disc (Item 7)				
	Disc with detachable lifting aid	✓	✓	*
	Bull race disc	✓	–	–
Seal type (Item 7)				
Sealing	BOROFLOAT glass	*	✓	*
	Virgin PTFE	✓	✓	✓
	PTFE-TFM + 25% carbon	✓	*	✓
	As per customer specification, e.g. Hastelloy®	✓	✓	✓

Overview

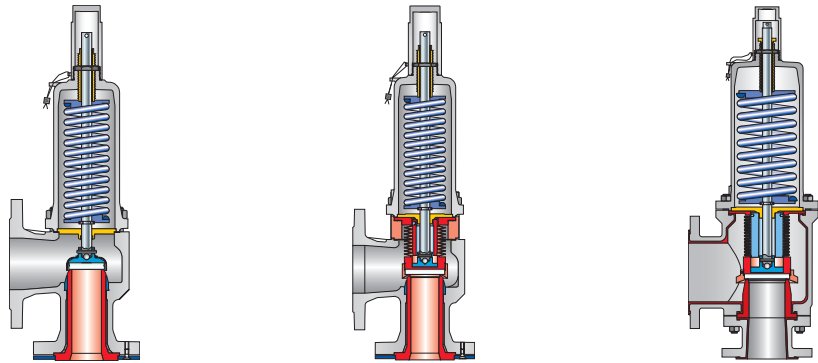

Options	Type	546	5466	447
Balanced bellows (Item 15, Item 7)				
	Balanced bellows	*	–	–
	PTFE bellows	✓	*	*
	Special material e.g. Hastelloy®	✓	–	✓
Caps and levers (Item 40)				
	H2	✓	✓	✓
	H4	✓	✓	✓
Test gag				
	H2	✓	✓	✓
	H4	✓	✓	✓
Bonnet (Item 9)				
	Closed	*	*	*
	Open	–	–	–
Lift indicator				
	Cap H2	–	–	–
	Lever H4	✓	✓	✓
Lift restriction				
	Sleeve	✓	✓	✓
	Set screw	✓	✓	✓

Caps and levers – subassembly item 40

Cap H2

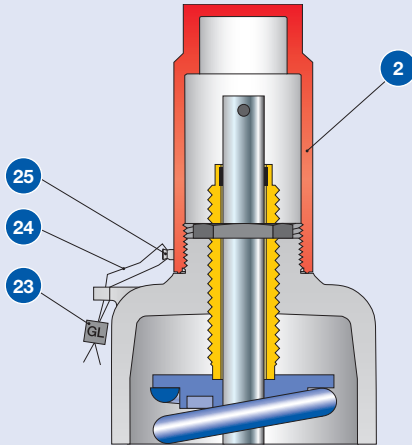

Packed lever H4

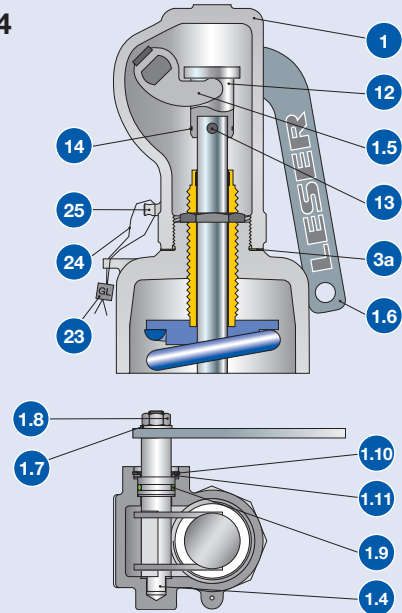

Blockierschraube

Cap H2: J70
Packed lever H4: J69

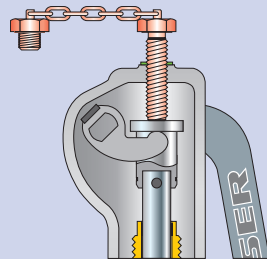
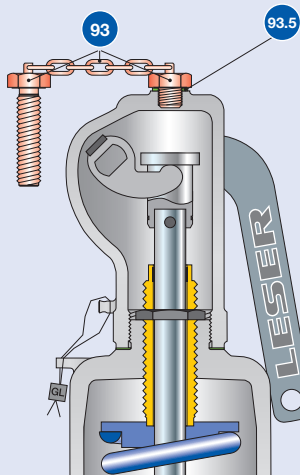

BLOCKED
Remove screw
after testing

Test gag

The test gag presses on the spindle and keeps the safety valve closed, even if the system pressure exceeds the set pressure of the valve.

The test gag is used to:

- perform the pressure test in a system without disassembling the safety valve.

- be able to make an adjustment to each individual valve in systems with multiple safety valves. The test gag must be removed after testing, otherwise the safety valve will not protect the system against impermissible overpressure.

Caps and levers – subassembly item 40

Materials		Steel		Stainless steel	
Item	Components	Cap H2	Packed lever H4	Cap H2	Packed lever H4
1	Lever cover	–	0.7040	–	1.4408
		–	Gr. 60-40-18	–	CF8M
2	Cap	1.0460	–	1.4404	–
		SA 105	–	316L	–
3a	Spacer	–	1.4571	–	1.4571
		–	316Ti	–	316Ti
1.4	Shaft/bolt	–	1.0718	–	1.4404
		–	Steel	–	316L
1.5	Lifting fork	–	1.0531	–	1.4571
		–	Steel	–	316Ti
1.6	Lever	–	1.0036	–	1.4301
		–	Steel	–	304
1.7	Washer	–	1.4401	–	1.4301
		–	316	–	304
1.8	Nut	–	A2/Poly	–	1.4401
		–	2H	–	8M
1.9	O-ring	–	FKM	–	–
		–	–	–	–
1.9	Packing ring precast	–	–	–	Graphite
		–	–	–	–
1.10	Retaining clip	–	Steel	–	–
		–	–	–	–
1.10	Nut	–	–	–	1.4104
		–	–	–	Chromium steel
1.10	Packing gland	–	–	–	1.4404
		–	–	–	316L
1.11	Support ring	–	Steel	–	–
		–	–	–	–
12	Spindle cap	–	1.0718	–	1.4404
		–	Steel	–	316L
13	Pin	–	Steel	–	1.4401
		–	–	–	8M
14	Securing ring	–	1.4571	–	1.4571
		–	316Ti	–	316Ti
23	Seal	Plastic	Plastic	Plastic	Plastic
24	Seal wire	1.4541	1.4541	1.4541	1.4541
		321	321	321	321
25	Sealing nose	1.4435	–	1.4435	1.4435
		316L	–	316L	316L
93	Test gag	1.4401	1.4401	1.4401	1.4401
		B8M	B8M	B8M	B8M
93.5	Washer	Vulcanised fibre	Vulcanised fibre	Vulcanised fibre	Vulcanised fibre

Please note:

- LESER reserves the right to make changes.
- LESER may use higher quality materials without giving prior information.
- Each component can be replaced by another material according to the customer's specification.

Balanced bellows and back pressure compensation

Compensation for back pressure

Balanced bellows are generally used for two applications:
 – to compensate for back pressure
 – to seal off the bonnet from the outlet chamber

The back pressure acts on the reverse side of the disc, creating a force in the closing direction (F_C). The balanced bellows constitutes an area equal to the seat area, creating a force acting in the opening direction (F_O), thus compensating the force in closing direction.

A quantitative representation is shown in the table below:

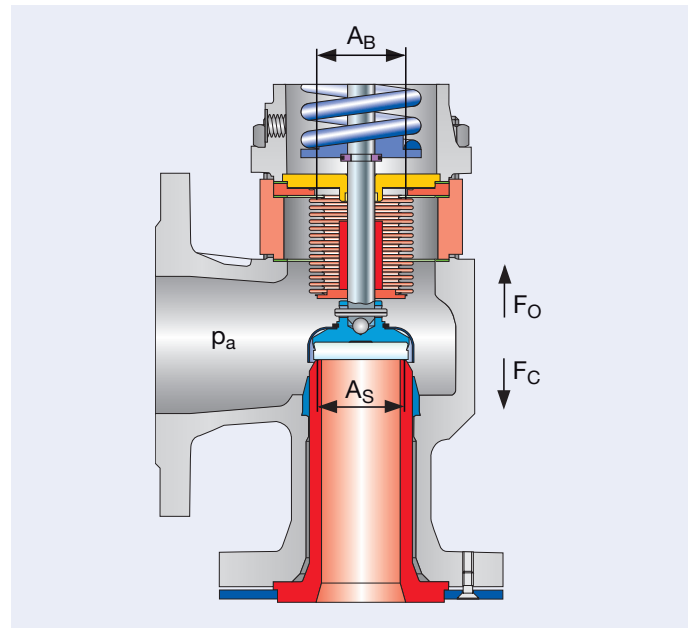

Type 546

Actual area	Back pressure	Actual force	Direction of force	Compensation criteria
Seat area = A_S	p_a	$F_C = p_a \times A_S$	closing	$A_S = A_B$
Bellows area = A_B	p_a	$F_O = p_a \times A_B$	opening	$F_C = F_O$

Sealing the bonnet from the outlet chamber

LESER's balanced bellows reliably seal the bonnet from the outlet chamber; protecting the guide, moving parts and the spring from problems associated with the fluid, such as dirt, corrosion, impurities or temperature.

Bellows design

Type	Balanced bellows		PTFE bellows	
	546	5466	447	447
Design				
Bonnet spacer	*	*	–	–
Control thread	DIN ISO 228-1, G 1/4	*	*	*
	ASME B1.20.1 NPT 1/2"	✓	✓	✓

To check the effectiveness of the bellows, an control thread G¹/₄ is fitted into the bonnet as per DIN ISO 228-1. For safe discharge, especially of aggressive, toxic media, a discharge pipe G¹/₄ can be installed if necessary.

Option code

Bonnet closed	Option	Code	546	5466	447
	Bellows	J78	–	–	–
	Control thread NPT 1/2"	J95	–	–	–

The dimensions and weights for safety valves with a stainless steel bellows construction are to be taken from the respective "Dimensions and Weights" tables. The set pressures as well as the temperature ranges are displayed in the table "Pressure/Temperature ratings" for each type.

Back pressure compensation of the PTFE bellows

For Types 5466 and 447 with a PTFE bellows, the maximum back pressure to the PTFE bellows is 35 % of the set pressure, but never more than 1,6 bar with regard to the pressure-temperature diagram shown below. The PTFE bellows is back-pressure compensating within these limits.

The maximum back pressure is comprised of the built-up back pressure that occurs during the discharge of the valve, and the superimposed back pressure, which might occur from a blowdown system.

The temperature at the outlet refers to the constant effective temperature in the outlet chamber of the valve. A short-term higher temperature during the discharge of the valve is permissible.

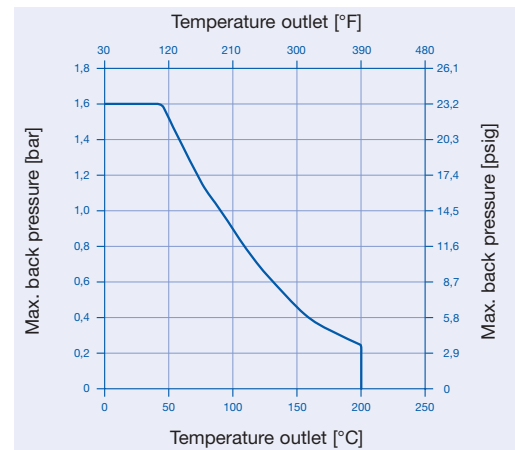

Pressure temperature ratings PTFE bellows

Type 546 balanced bellows – subassembly item 15

LESER offers a balanced bellows design for safety valves. Balanced bellows are used for two areas of applications:

- for compensation of the effect of back pressure
- For reliable sealing of the bonnet against the blow-off chamber

Materials		
Item	Components	Type 546
15.1	Lower adator	1.4404 316L
15.2	Upper adator	1.4404 316L
15.3	Balanced bellows	1.4571 316Ti
15.5	Housing	– –
11	Bonnet spacer	1.4404 316L
55	Stud	1.4401 B8M
60	Gasket	Graphite / 1.4401 Graphite / 316

Hastelloy bellows or bellows made of special materials are available on request.

Conversion kits			
Item	Components	Quantity	Materials
8	Guide	1	1.4404 316L
11	Bonnet spacer	1	1.4404 316L
12	Spindle	1	1.4404 316L
15	Balanced bellows	1	1.4571 316Ti
55	Stud	4, 8, 12 dependant on valve size	1.4401 B8M
60	Gasket	2, 3 dependant on valve size	Graphite / 1.4401 Graphite / 316
–	Installation instructions WI_3037.05	1	

Article numbers and spare parts, see the “Spare parts” section of the respective valve type.

Sealing plate – subassembly item 7

Type 546, 5466 and Type 447

Non-metallic seal seat / nozzle, item 5 and disc – subassembly item 7

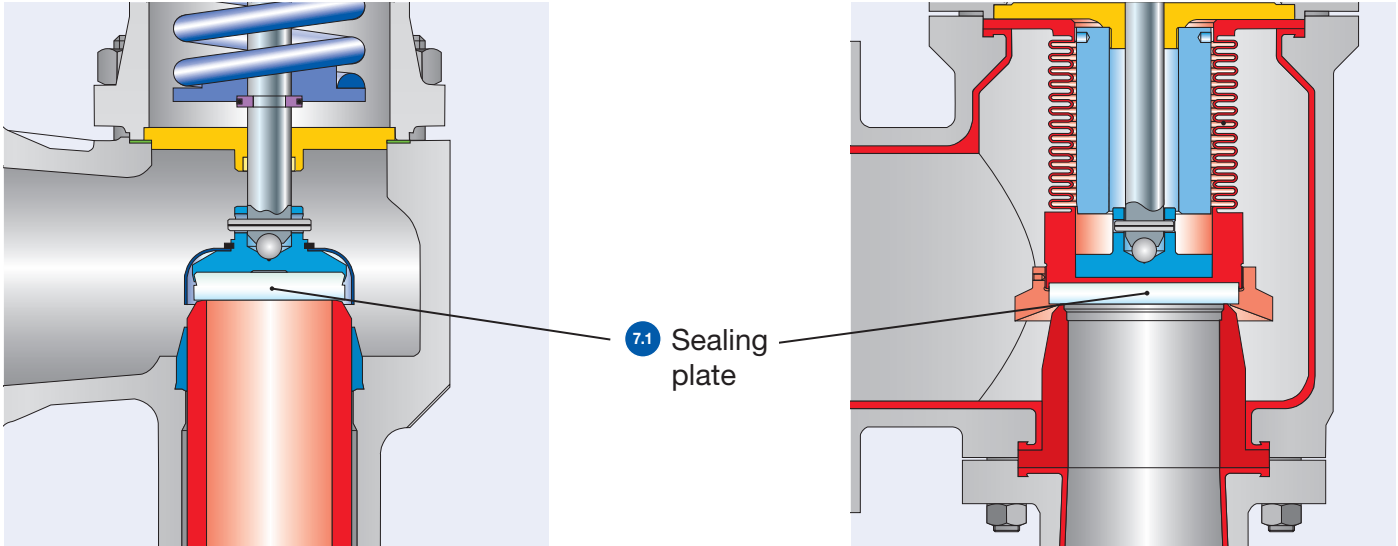

Type 546

Type 447

For safety valves for chemical processes, LESER uses sealing plates (Item 7.1) made of BOROFLOAT glass as a seat seal. This glass is produced worldwide using the same method and is characterised by:

- high temperature resistance
- quenching strength
- improved mechanical strength
- high chemical resistance
- surface quality of the sealing surface as per ISO 10110: $\diamond\diamond$ = fine, polished

Features		BOROFLOAT glass	
Optical features		Physical features	
Water resistance as per ISO 719-HGB:	1	Density (at 25 °C):	2,23 g/cm ³
Water resistance as per ISO 719-HGA:	1	Elasticity module:	63 kN/mm ²
Acidity class as per ISO 1776:	1	Knoop hardness HK _{0,1/20} (measurement as per EN DIN/ISO 9385):	480
Alkali resistance class as per ISO 695-A:	2	linear therm. coefficient of expansion $\alpha_{(20-300^{\circ}\text{C})}$:	3,25 x 10 ⁻⁶ K ⁻¹

Sealing plate	546	5466	447
PTFE-TFM + 25% carbon	–	*	–
BOROFLOAT glass	*	✓	*
Hastelloy®	✓	✓	✓
as per customer specification	✓	✓	✓

Lift indicator

The lift indicator is used in the process technology to monitor the operating condition of a safety valve.

Depending on the type of valve, LESER equips the lifting device H4 or the bonnets with the receptacle for the lift indicator.

For safety valves with lift indicators, the opening of the valve during opening or the lifting operation is signalled as of a specific lift (min. 1mm / 0,04 inch).

LESER uses inductive DC lift indicators with two-wire technology Type DIN EN 60947-5-6 (NAMUR).

The indicators are approved for use in explosion-prone areas of Zone 0 (Ex II 1 D Ex iaD 20 T6). Other indicators that meet customer specifications can be used.

Technical data for lift indicators can be found on the manufacturer's homepage: www.pepperl-fuchs.com

Gas-tight construction on request

For installation instructions for lift indicators, see WI_3323.02.

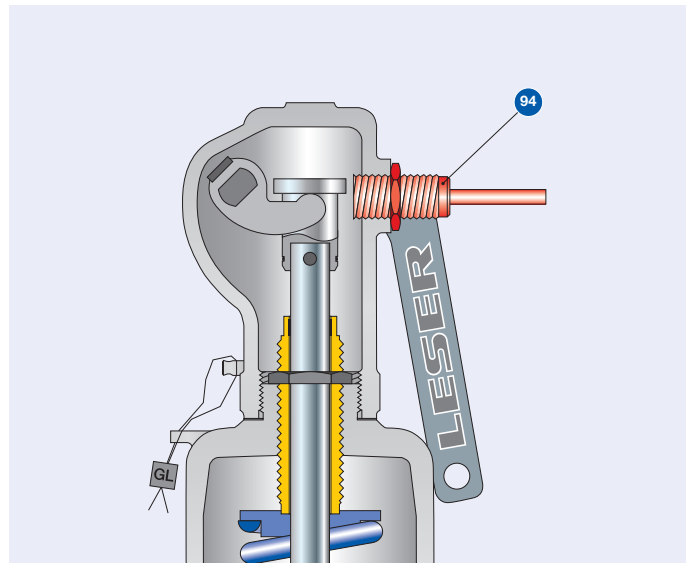

Lifting device H4

Specification

Item	Component	Option code
40	Lifting device H2 with receptacle for lift indicator M18 x 1 [mm]	J39
94	Lift indicator M18 x 1, used type = PEPPERL+FUCHS NJ5-18GK-N	J93

Functional diagram

A, closed position

For a closed valve, the lift indicator is positioned on the side, in front of the coupling or the control sleeve.

B, open position

If the safety valve opens or if the safety valve is vented (in both cases, min. 1 mm 0,04 inch) the lift indicator changes its state and switches. If the lift indicator unscrews, e.g. from vibrations, there is also a switching operation.

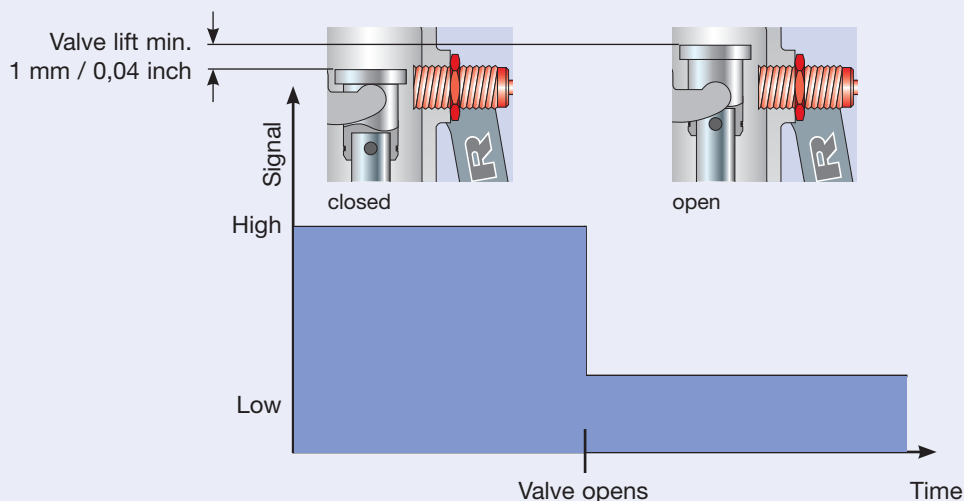

Lift restriction

The lift stopper is used to adjust the safety valve to the required discharge mass flow and does not affect the operation of the safety valve.

A lift stopper must meet the requirements of the following rules and regulations and standards.

Requirements		
Rules and requirements/standards	EN ISO 4126-1, Abschnitt 5.1.3.	AD 2000-Merkblatt A2, Abschnitt 10.3
Lift	≥ 30 % of the full lift not less than 1,0 mm / 1/16 inch	not less than 1,0 mm / 1/16 inch
Coefficient of discharge	–	$\alpha_w [S/G] \geq 0,08$
	–	$\alpha_w [L] \geq 0,05$
Name plate marking	Marking of reduced coefficient of discharge	Marking of reduced coefficient of discharge
Design according to EN ISO 4126-1	For valves with a lift stopper to adapt to the required discharge mass flow, this device must not have an adverse effect on the operation of the valve. If it is adjustable, the lift stopper device must be setup such that the adjustable part can be mechanically secured and sealed. The lift stopper device must be installed and sealed by the manufacturer.	

Calculation of the lift stopper

The following resources are available for calculating the lift stopper:

- the Diagram for evaluation of the ratio of lift / narrowest flow diameter (h/d_0) in reference with coefficient of discharge (K_{dr}/α_w). An example of working with the chart can be found on page 20.

- LESER sizing program "VALVESTAR®"
- Online sizing with VALVESTAR web www.valvestar.com

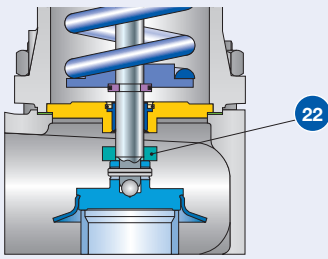
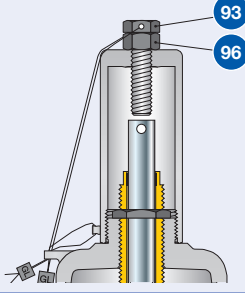
Lift restriction		Lift restriction by bush	Lift restriction by gag
Design			
Option code		J51	Cap H2: J52 Lifting device H4: J50
Availability			
Type 546		✓	✓
Type 447		✓	✓
Materials			
Item	Component		
22	Bush	1.4404	–
		316L	–
93	Stud	–	1.4401
		–	B8M
96	Nut	–	1.4401
		–	8M

The different requirements are listed in the following and relevance for LESER safety valves is explained. They define LESER as follows:

REACH – EU Chemicals Regulation No. 1907/2006

The EU Chemicals Law REACH (English: REACH – **R**egistration, **E**valuation and **A**uthorisation of **C**hemicals) registers, evaluates and checks the composition of chemical materials. The PTFE materials used in the safety valves of the LESER Critical Service product group are assigned to the polymers

and preparations materials groups according to REACH, and according to today's perspective of our suppliers, they comply with EU Regulation 1907/2006 for later registration, evaluation and approval.

Difference between an anti-static lining and grounding a safety valve.

Pure fluoro-plastics are electrical insulators. If this material property is not desired, then by adding a component of approx. 2 to 4% graphite, soot or charcoal you end up with an antistatic lining. It is conductive and removes electric charge carriers from the plastic surface in contact

with the medium, through the plastic wall to the metallic fittings casing. The charge carriers are discharged from the fittings casing to a ground potential point by grounding (e.g. grounding bolts).

Note on export restrictions for Type 447

Note on export restrictions

Type 447 is subject to an export restriction according to EU regulation No. 1334/2000 as well as regulation No. 1167/2008 Position 2B350g.

In the event of an export project, LESER requests the respective information on the final destination / use in the inquiry or order.

Exception

For direct export by LESER, exception EU 001 can be used for the following countries:

Australia, Japan, Canada, New Zealand, Norway, Switzerland and USA.

LESER worldwide

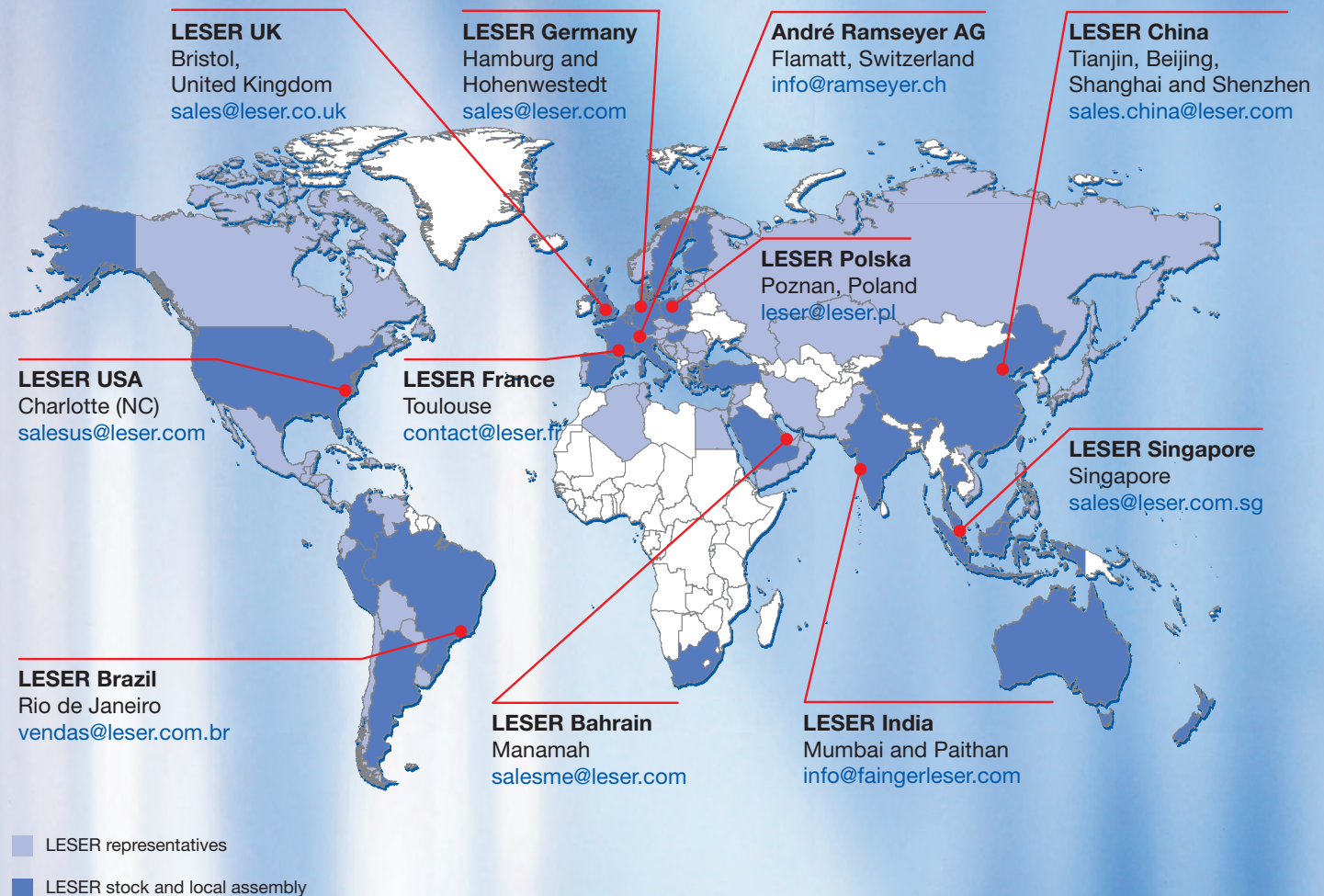

Critical Service
Edition November 2014 / 1.000
0777.5649

LESER

The-Safety-Valve.com