



High Performance

Flanged Safety Relief Valves
Series 441 Full nozzle
Series 458

CATALOG 2

LESER

The-Safety-Valve.com

LESER Safety Valves for every industrial application



High Performance

Series 441 Full nozzle

Type 441, 442 Full nozzle DIN
Type 441, 442 Full nozzle ANSI



Series 458

Type 455, 456
Type 457, 458



Series 441

Type 441, 442 DIN
Type 441, 442 ANSI

Series XXL

Type 441, 442 XXL

Series 444

Type 444 DIN
Type 444 ANSI

Please refer to
High Performance
Catalog 1

Compact Performance



API



Clean Service



Critical Service

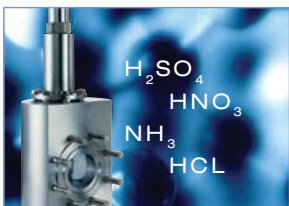

Modulate Action



Best Availability

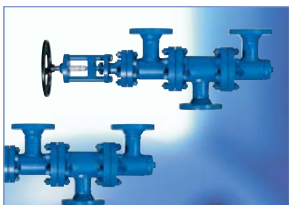

General

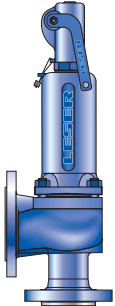

Type 441, 442 Full nozzle DIN

DN 20, 40, 50

Set pressure 0,1 – 40 bar, 1,5 – 580 psig

Flanges according to DIN EN 1092

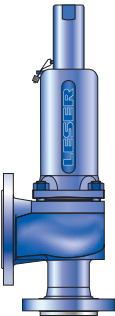

Type 441, 442 Full nozzle ANSI

Valve size 1" – 4"

Set pressure 0,1 – 51 bar, 1,5 – 740 psig

Flanges according to ASME B16.5

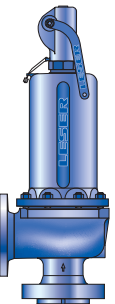

Type 455, 456

DN 25 – 100, 1" – 4"

Set pressure 2,5 – 100 bar, 36 – 1450 psig

Flanges according to DIN EN 1092 and ASME B16.5

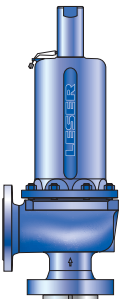

Type 457, 458

DN 25 – 150, 1" – 6"

Set pressure 2,5 – 300 bar, 36 – 4350 psig

Flanges according to DIN EN 1092 and ASME B16.5



Options

Overview

Chapter/Page

General	00/01
Applications, General design features	00/02
Valve finder	00/03
Valve selection	00/05
How to use: Signs and symbols, Flange drillings and facings	00/07
How to use: Determination of coefficient of discharge K_{dr}/α_w	00/08
How to use: Capacity sheets	00/09
LESER Effective Orifice LEO_{sg}	00/11
LESER Effective Orifice LEO_L	00/12
Sour gas service	00/13

Type 441, 442 Full nozzle ANSI

07/01

Materials	
• Conventional design	07/02
• Balanced bellows design	07/04
How to order	
• Numbering system	07/06
• Article numbers	07/08
Dimensions and weights	
• Metric Units	07/10
• US Units	07/11
Pressure temperature ratings	
• Metric Units	07/12
• US Units	07/13
Flange drillings and facings	07/14
Order information – Spare parts	07/15
Available options	07/16
Approvals	07/17
Capacities	
• Steam [Metric Units + US Units]	07/18
• Air [Metric Units + US Units]	07/19
• Water [Metric Units + US Units]	07/20
Determination of coefficient of discharge K_{dr}/α_w	07/21

LESER Type

Chapter/Page

Type 441, 442 Full nozzle DIN	06/01
Materials	
• Conventional design	06/02
• Balanced bellows design	06/04
How to order	
• Numbering system	06/06
• Article numbers	06/08
Dimensions and weights	
• Metric Units	06/10
• US Units	06/11
Pressure temperature ratings	
• Metric Units	06/12
• US Units	06/13
Flange drillings and facings	06/14
Order information – Spare parts	06/15
Available options	06/16
Approvals	06/17
Capacities	
• Steam [Metric Units + US Units]	06/18
• Air [Metric Units + US Units]	06/19
• Water [Metric Units + US Units]	06/20
Determination of coefficient of discharge K_{dr}/α_w	06/21

Type 455, 456

08/01

Materials	
• Conventional design	08/02
• Balanced bellows design	08/04
How to order	
• Numbering system	08/06
• Article numbers	08/08
Dimensions and weights	
• Metric Units	08/10
• US Units	08/11
Pressure temperature ratings	
• Metric Units	08/12
• US Units	08/13
Flange drillings and facings	08/14
Order information – Spare parts	08/15
Available options	08/16
Approvals	08/17
Capacities	
• Steam [Metric Units + US Units]	08/18
• Air [Metric Units + US Units]	08/19
• Water [Metric Units + US Units]	08/20
Determination of coefficient of discharge K_{dr}/α_w	08/21

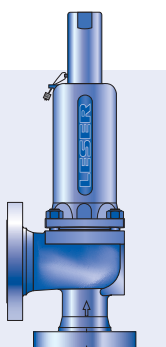

Type 441
Cap H2
Closed bonnet
Conventional design

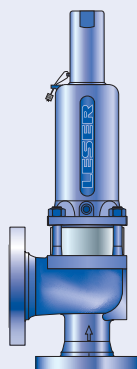

Type 441
Cap H2
Closed bonnet
Balanced bellows design

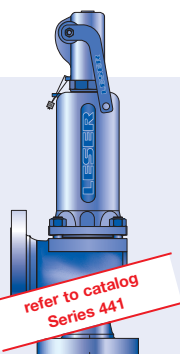

Type 441
Packed lever H4
Closed bonnet
Conventional design

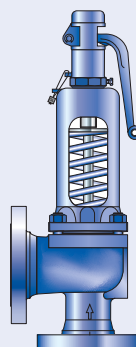

Type 442
Plain lever H3
Open bonnet
Conventional design

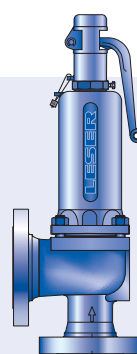

Type 441
Plain lever H3
Closed bonnet
Conventional design



Type 444
Cap H2
Closed bonnet
Conventional design

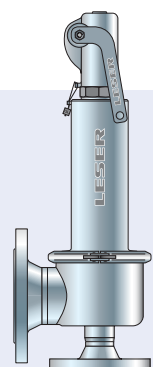

Type 444
Packed lever H4
Closed bonnet
Conventional design

Type 457, 458		09/01
Materials		
• Conventional design		09/02
• Balanced bellows design		09/04
How to order		
• Numbering system		09/06
• Article numbers		09/08
Dimensions and weights		
• Metric Units		09/10
• US Units		09/11
Pressure temperature ratings		
• Metric Units		09/12
• US Units		09/13
Flange drillings and facings		09/14
Order information – Spare parts		09/16
Available options		09/18
Approvals		09/19
Capacities		
• Steam [Metric Units + US Units]		09/20
• Air [Metric Units + US Units]		09/22
• Water [Metric Units + US Units]		09/24
Determination of coefficient of discharge K_{dr}/α_w		09/26

Options		99/01
Overview		99/02
Caps and Levers		99/04
Caps and Levers bolted		99/06
Metal seat		99/08
Soft seal disc		99/10
Soft seal		99/12
Balanced bellows		99/14
High temperature equipment		99/16
Elastomer bellows		99/17
Disc		99/18
Heating jacket		99/20
O-ring damper		99/22
Lift indicator		99/24
Lift restriction		99/25
First in safety		
Fax Order		

Type 441, 442	
Materials	
How to order	
Dimensions and weights	
Pressure temperature ratings	
Flange drillings and facings	
Order information – Spare parts	
Available options	
Approvals	
Capacities	
Determination of coefficient of discharge K_{dr}/α_w	

refer to catalog
Series 441

Type 441, 442 XXL	
Materials	
How to order	
Dimensions and weights	
Pressure temperature ratings	
Flange drillings and facings	
Order information – Spare parts	
Available options	
Approvals	
Capacities	
Determination of coefficient of discharge K_{dr}/α_w	

refer to catalog
Series XXL

Type 444	
Materials	
How to order	
Dimensions and weights	
Pressure temperature ratings	
Flange drillings and facings	
Order information – Spare parts	
Available options	
Approvals	
Capacities	
Determination of coefficient of discharge K_{dr}/α_w	

refer to catalog
Series 444

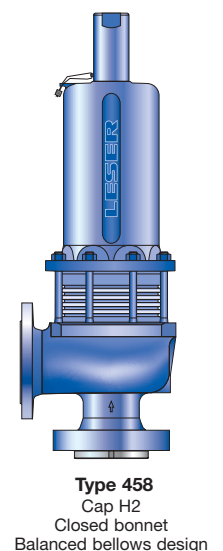
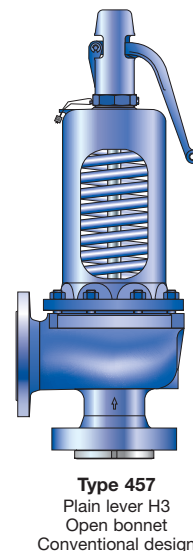
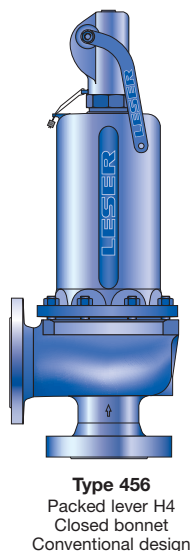
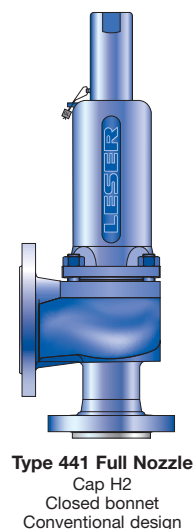
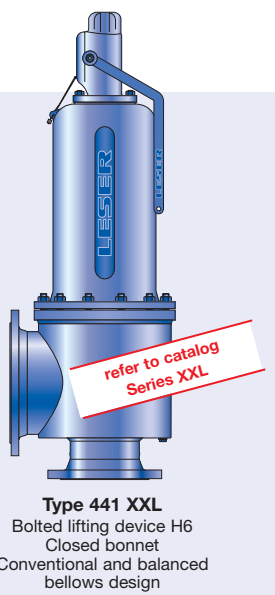

LESER – High Performance Safety Valves

The High Performance product group represents

- ✓ High capacity related to the safety valve size
- ✓ High customisability
- ✓ Excellent price / performance ratio

LESER's High Performance Safety Valves

- Are designed to meet all industrial applications.
- Open rapidly with an overpressure of 5 % to the full design lift.
- Are used particularly for vapours and gases where the maximum mass flow has to be discharged rapidly.
- Have a maximum blowdown of minus 10 % for steam/gas service and minus 20 % for liquid service.
- Are one of the best selling spring loaded safety valve worldwide.
- Are developed in a close cooperation with plant engineers and service specialists.
- Serve for protection of processes and equipment.
- Are approved by all important approval organisations worldwide which ensures the worldwide applicability e.g.:
 - European Community: CE-marking acc. to Pressure Equipment Directive (PED) 97 / 23 / EC and EN ISO 4126-1
 - USA: UV-stamp acc. to ASME Section VIII Division 1, National Board certified capacities
 - Germany: VdTÜV approval acc. to PED, EN ISO 4126-1, TÜV SV 100 and AD 2000-Merkblatt A2
 - Canada: Canadian Registration Number acc. to the requirements of particular provinces
 - China: AQSIQ based on the approval acc. to ASME Section VIII Division 1 and AD 2000-Merkblatt A2

Furthermore, all LESER High Performance safety valves are designed, marked, produced and approved acc. to the requirements of the following regulations (directives, codes, rules and standards).

EN ISO 4126-7, EN 12266-1/-2, EN 1092 Part I and II flanging
 ASME PTC 25, ASME-Code Sec. II, ASME B 16.34 and ASME B16.5- flanging, API Std. 527, API RP 576
 AD 2000-Merkblatt A4, AD 2000-Merkblatt HP0, TRD 110, TRD 421, TRD 721



Applications

LESER – High Performance Safety Valves

are the ultimate solution for all industrial applications for steam, gas and liquid.

Typical applications for LESER High Performance Safety Valves are:

Series 441

- Protection of chemical processes and equipment (e.g. distillation columns)
- Heat exchangers
- Low and medium pressure steam
- Blowers and turbo compressors

Series XXL

- Low pressure steam at big power stations
- Capacities beyond the limits of API and Series 441

Series 444

- OEM in dying machines or filter constructions
- Stainless steel applications up to 16 bar / 232 psig

Series 441 Full Nozzle

- Same applications like Series 441 when full nozzle design is preferred.
- Special requirement for nozzle material

Series 458

- Power stations and industrial superheated steam generation
- Required flange classes \geq PN 63 / CL600
- Protection of high pressure Chemical processes, e.g. NH_3 synthesis, CO_2 extraction
- Desalination plants

General Design Features

LESER's High Performance Safety Valves

offer a large variety of types, materials and options to suit any application:

- 14 valve sizes from DN 20 to DN 400 – $\frac{3}{4}$ " to 16" provide a high connectivity to the application
- Inlet pressure ratings PN 16 to PN 400 / class 150 to 2500 to fit all required design pressures
- Orifice sizes from E to $> 3 \times T$ cover all capacity requirements
- Large variety of body materials; e.g.
 - 0.6025 / grey iron
 - 0.7043 / ductile iron
 - 1.0619 / WCB
 - 1.4408 / CF8M
 - 1.7357 / WC6

can be selected acc. to the application

- Set pressures from 0,1 to 300 bar / 1,5 to 4350 psig make this product group suitable for all industrial processes
- Operating temperatures from -270 to 550 °C / -454 to 1022 °F cover a wide range of applications
- One design and spring (single trim) for steam, gas and liquid applications reduces the number of spare parts and ensure an easier maintenance.
- High capacity compared to the API requirements to reduce installation costs
- Ringless design needs no trim adjustments for easy maintenance
- One-piece spindle reduces friction which is leading to high operation accuracy
- Self-draining body design, avoids residues and reduces corrosion

LESER's High Performance Safety Valves

can be customized with a great variety of options, e.g.

- O-ring disc for superior tightness
- Stellite or hardened metal sealing for longer product life
- Stainless steel bellows for back pressure compensation
- Heating jacket for applications with high viscosity fluids
- Every part can be replaced by other material acc. to customer specification

How to find the right Product Group

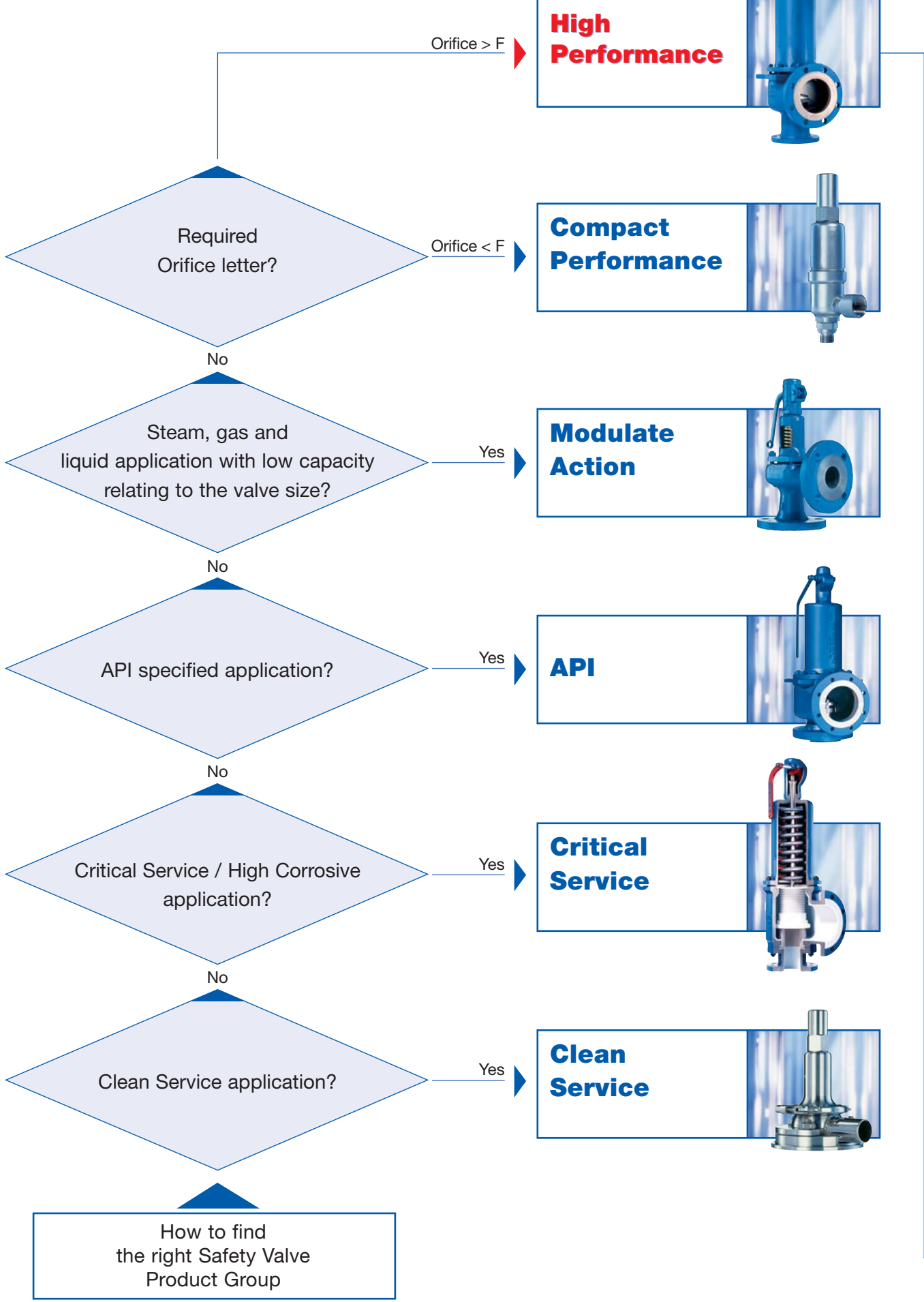

How to find the right Safety Valve

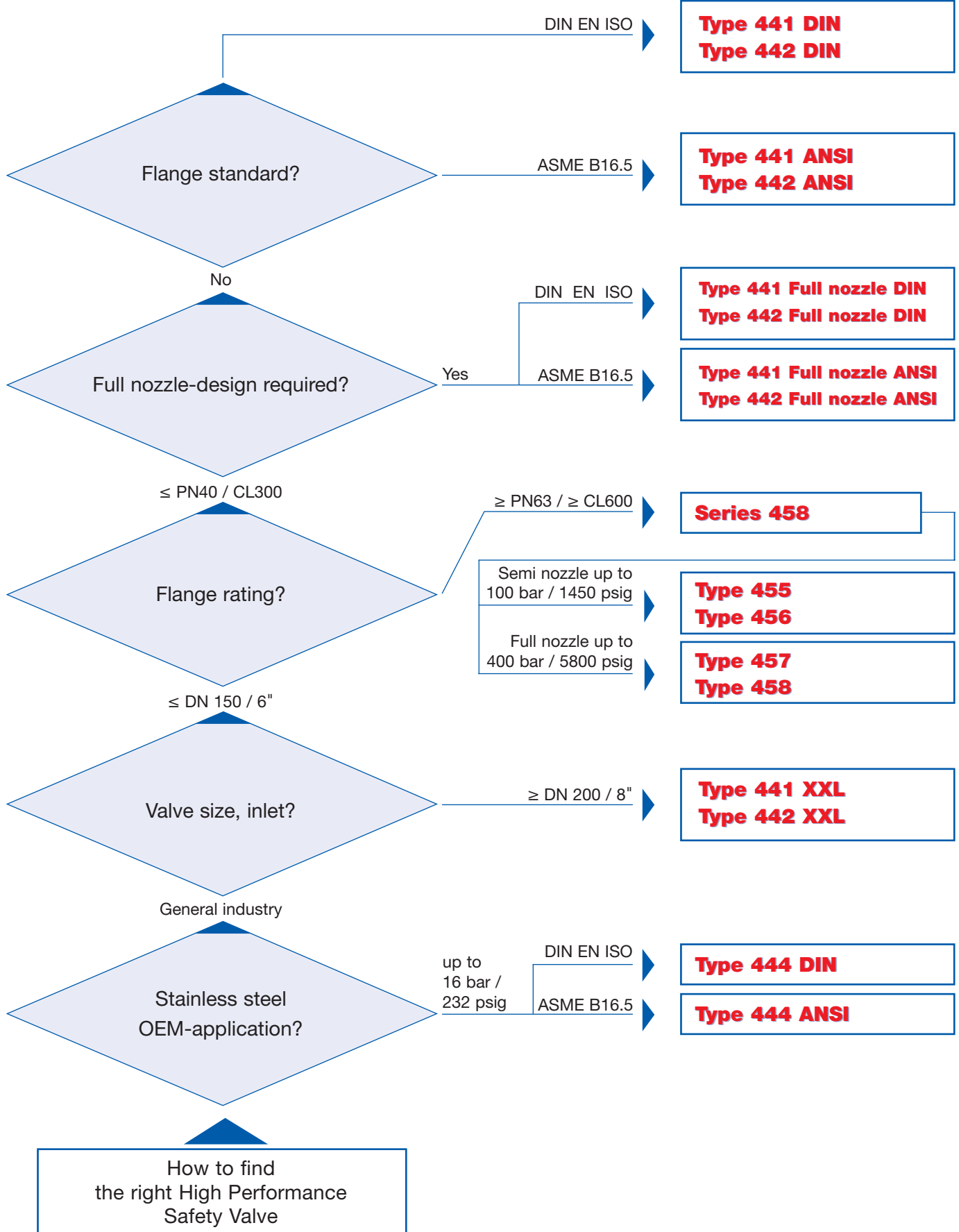

Valve selection

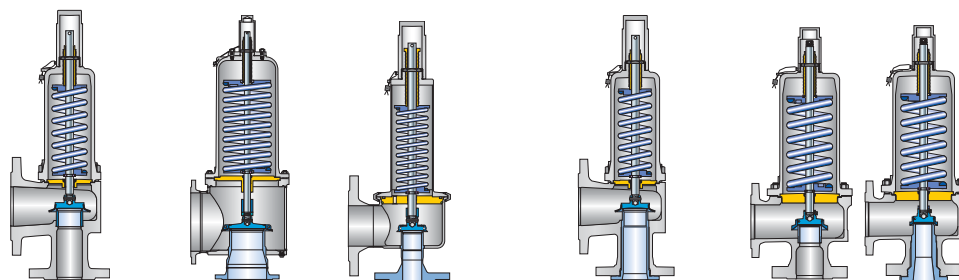
LESER

Valve size

Type	441, 442 DIN	441, 442 ANSI	441, 442 XXL	444 DIN	444 ANSI	441, 442 Full nozzle DIN	441, 442 Full nozzle ANSI	455, 456	457, 458
min.	DN 20 (¾")	(DN 25) 1"	DN 200 8"	DN 25 –	– 1"	DN 25 (1")	(DN 25) 1"	DN 25 1"	DN 25 1"
max.	DN 200 (8")	(DN 100) 4"	DN 400 16"	DN 80 –	– 3"	DN 50 (2")	(DN 100) 4"	DN 100 4"	DN 150 6"

Materials

Type	441, 442 DIN	441, 442 ANSI	441, 442 XXL	444 DIN	444 ANSI	441, 442 Full nozzle DIN	441, 442 Full nozzle ANSI	455, 456	457, 458
0.6025 Grey iron	✓	–	–	–	–	–	–	–	–
0.7043 Ductile Gr. 60-40-18	✓	–	–	–	–	–	–	–	–
1.0619 WCB	✓	✓	–	–	–	–	–	–	–
1.0460 / 1.0425 Carbon steel	–	–	✓	–	–	✓	✓	✓	✓
1.4408 CF8M	✓	✓	–	–	–	–	–	–	–
1.4404 316L	–	–	–	✓	✓	✓	✓	–	–
1.4581 CF10M	–	–	–	–	–	–	–	✓	✓
1.4571 316Ti	–	–	✓	–	–	–	–	–	–
1.7357 WC6	–	–	–	–	–	–	–	✓	✓

Set pressure

Type	441, 442 DIN	441, 442 ANSI	441, 442 XXL	444 DIN	444 ANSI	441, 442 Full nozzle DIN	441, 442 Full nozzle ANSI	455, 456	457, 458
Metric Units min. [bar]	0,1	0,1	0,2	0,1	0,1	0,1	0,1	2,5	2,5
US Units min. [psig]	1,5	3	3	1,5	1,5	1,5	1,5	36	36
Metric Units max. [bar]	40	51	25	16	16	40	51	100	300
US Units max. [psig]	580	740	360	232	232	580	740	1450	4350

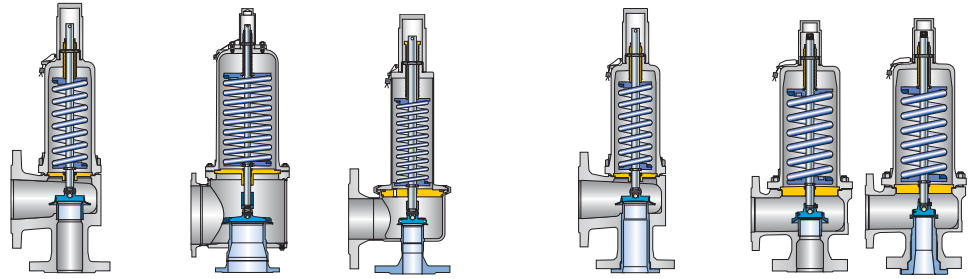

Temperature range

Type		441, 442 DIN	441, 442 ANSI	441, 442 XXL	444 DIN	444 ANSI	441, 442 Full nozzle DIN	441, 442 Full nozzle ANSI	455, 456	457, 458
acc. to DIN EN	min. [°C]	-270	-270	-196	-45	-45	-270	-270	-85	-270
	max. [°C]	450	450	550	200	200	450	450	450	550
	min. [°F]	-454	-454	-321	-49	-49	-454	-454	-121	-454
	max. [°F]	842	842	1022	392	392	842	842	842	1022
acc. to ASME	min. [°C]	-268	-268	-184	-45	-45	-268	-268	-29	-268
	max. [°C]	538	538	427	200	200	538	538	450	538
	min. [°F]	-450	-450	-300	-49	-49	-450	-450	-20	-450
	max. [°F]	1000	1000	800	392	392	1000	1000	842	1000

Capacity

Type		441, 442 DIN	441, 442 ANSI	441, 442 XXL	444 DIN	444 ANSI	441, 442 Full nozzle DIN	441, 442 Full nozzle ANSI	455, 456	457, 458
LEO _{S/G}	min.	0,283	0,462	23,8	0,462	0,462	0,462	0,462	0,399	0,224
LEO _{S/G}	max.	23,8	7,39	76,0	4,78	4,78	1,85	7,39	5,46	11,4
Orifice _{S/G}	min.	1,4 x E	1,5 x F	1,5 x R	1,5 x F	1,5 x F	1,5 x F	1,5 x F	1,3 x F	1,1 x E
Orifice _{S/G}	max.	1,5 x R	1,2 x P	3,0 x T	1,1 x N	1,1 x N	1,0 x K	1,2 x P	1,3 x N	1,0 x Q
LEO _L	min.	0,316	0,516	26,6	0,516	0,516	0,516	0,516	0,429	0,241
LEO _L	max.	26,6	8,26	84,9	5,34	5,34	2,07	8,26	5,87	10,9
Orifice _L	min.	1,0 x F	1,0 x G	1,0 x T	1,0 x G	1,0 x G	1,0 x G	1,0 x G	1,4 x F	1,2 x E
Orifice _L	max.	1,0 x T	1,3 x P	33 x T	1,2 x N	1,2 x N	1,1 x K	1,3 x P	1,4 x N	1,7 x P

Approvals

Type			441, 442 DIN	441, 442 ANSI	441, 442 XXL	444 DIN	444 ANSI	441, 442 Full nozzle DIN	441, 442 Full nozzle ANSI	455, 456	457, 458
Country	Code	Media									
Europe	DIN EN ISO 4126-1 CE-marking	S/G/L	072020111Z 0008/0/08-2	072020111Z 0008/0/08-2	072020111Z 0008/0/08-2	072020111Z 0008/0/08-2	072020111Z 0008/0/08-2	072020111Z 0008/0/08-2	072020111Z 0008/0/08-2	072020111Z 0008/0/11	072020111Z 0008/0/11
Germany	AD 2000- Merkblatt A2	S/G/L	TÜV SV 576	TÜV SV 576	TÜV SV 576	TÜV SV 576	TÜV SV 576	TÜV SV 576	TÜV SV 576	TÜV SV 934	TÜV SV 934
United States	ASME VIII	S/G	M37044	M37044	M37044	M37044	M37044	M37044	M37044	M37066 M37088	M37066 M37088
		L	M37055	M37055	M37055	M37055	M37055	M37055	M37055	M37077 M37099	M37077 M37099
Canada	CRN	S/G/L	OG1182.9C	OG1182.9C	OG1182.9C	OG1182.9C	OG1182.9C	OG1182.9C	OG1182.9C	-	-
China	AQSIQ	S/G/L	02301T	02301T	02301T	02301T	02301T	02301T	02301T	02301T	02301T
Russia	DIN GOST GOSGOTTECHNADZOR		✓	✓	✓	✓	✓	✓	-	✓	✓

Classification societies

		BV	DNV	GL	LREMEA	RINA
Bureau Veritas	BV	✓	✓	✓	-	-
Det Norske Veritas	DNV	✓	✓	-	-	-
Germanischer Lloyd	GL	✓	✓	✓	-	-
Lloyd's register EMEA	LREMEA	✓	✓	✓	-	-
Registro Italiano Navale	RINA	✓	✓	up to DN 250	-	-

General signs and symbols

*	This option is covered by standard design
✓	Available
–	Not possible

Signs and symbols for flange drillings and flange facings

*	Standard design, no option code required
(*)	Flange dimensions except flange thickness are in accordance with flange standard (e.g. ASME B16.5) Flange thickness is smaller (max. 2 mm), see “Multiple pressure rating”
–	Flange drilling/facing is not possible

Option code for flange drilling and dimension, e.g. H50

H50	Flange drilling as specified in flange standard Outer flange diameter, flange thickness and height of flange facing may be larger, see “Dimensions”
(H50)	Flange dimensions except flange thickness are in accordance with standard Flange thickness is smaller (max. 2 mm), see “Multiple pressure rating”
[H50]	Flange drilling as specified in standard/flange thickness may be smaller Outer flange diameter is smaller than required, but complete back side facing for nut is assured

Option code for flange facing, e.g. L36

L36	Flange facing as specified in flange standard
------------	---

General information concerning flange drillings and flange facings

Dimensions	<p>Flange dimensions of LESER Series 458 exceed flange dimension as mentioned in ASME / ANSI B16.5 and DIN EN 1092. This exceedance is in accordance with API Standard 526, Section 2.4.</p> <p>Dimensions: “For some valve designs, the inlet raised face height may substantially exceed the nominal dimension specified in ASME / ANSI B16.5 (and DIN EN 1092). Consult the manufacturer for exact dimension.”</p> <p>The reason for this exceedance is:</p> <ul style="list-style-type: none"> - height of nozzle placed in the inlet of valve - due to the outer diameter of the nozzle thread flange thickness has to be thicker than normal ASME / ANSI B16.5 and DIN EN 1092 dimension to achieve the required pressure rating
Multiple pressure rating	The flange standard shows the same drilling, facing and outer diameter for several pressure ratings, e.g. PN 16 up to PN 40 Due to the pressure rating of the casting LESER fulfills the requirements for flange thickness e.g. of PN 16 but not PN 40
Smooth finish	The effective MSS SP-6 (Edition 2001) does not mention “smooth finish” anymore. In MSS SP-6 (Edition 1980) “smooth finish” is defined for finishes of contact flanges as “250 µinch (6,3 µm) AARH max.”. LESER supplies flange facings according to ASME B16.5 – 1996, paragraph 6.4.4.3: “Either a serrated concentric or serrated spiral finish resulting in service finish from 125 µinch to 250 µinch average roughness shall be furnished.” This finish meets the requirements of MSS SP-6 (Edition 1980), which is not valid anymore!
Stock finish	Stock finish is not defined in any technical standard. If purchase orders show “stock finish” LESER supplies standard facing according to DIN or ASME (marked with * in table “Flange facings” of each valve series).

Materials

Please find below a summary of material codes at LESER. Please note that

- for every body material an inspection certificate 3.1 according to EN 10204 is available
- many materials have a multiple inspection certificate 3.1.

Material code	Flanged safety valve body Threaded safety valve inlet body	Body material is certified with 3.1 (EN 10204) for the following materials	
		EN	ASME
1	Grey iron	0.6025	cast iron
2	Carbon steel	1.0619	WCB, WCC
4	Stainless steel	1.4408, 1.4581	CF8M (Charpy test at -196°C), CF10M
5	Nodular cast iron	0.7043	ductile Gr. 60-40-18
7	High temperature carbon steel	1.7357	WC6

Sample Determination of K_{dr}/α_w : Type 441, 442 Full nozzle DIN, DN 25

Type 441, 442 Full nozzle DIN

Determination of coefficient of discharge in case of lift restriction or back pressure

- h = Lift [mm]
- d_0 = Flow diameter [mm] of selected safety valve, refer to table article numbers
- h/d_0 = Ratio of lift / flow diameter
- p_{a0} = Back pressure [bar_a]
- p_0 = Set pressure [bar_a]
- p_{a0}/p_0 = Ratio of back pressure / set pressure
- K_{dr} = Coefficient of discharge acc. to DIN EN ISO 4126-1
- α_w = Coefficient of discharge acc. to AD 2000-Merkblatt A2
- K_b = Back pressure correction factor acc. to API 520 topic 3.3

Diagram for evaluation of ratio of lift / flow diameter (h/d_0) in reference to the coefficient of discharge (K_{dr}/α_w)

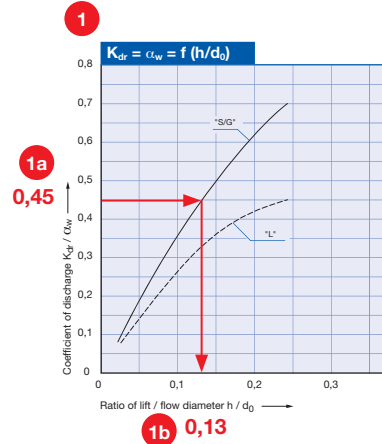
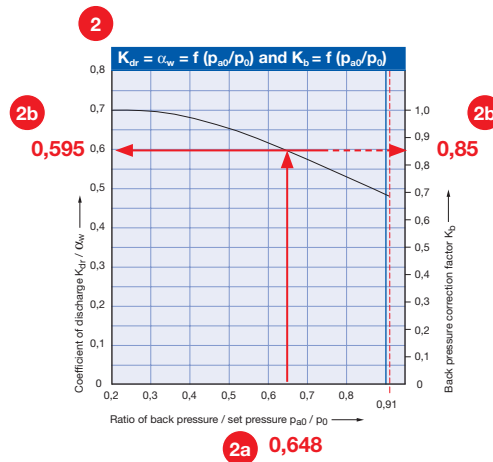

Diagram for evaluation of coefficient of discharge (K_{dr}/α_w) or K_b in reference to the ratio of back pressure / set pressure (p_{a0}/p_0)



Explanation

Sample – Type 441, 442 Full nozzle DIN, DN 25 flow diameter $d_0 = 23$ mm, rated lift $h = 5,6$ mm, K_{dr}/α_w S/G = 0,7

1 Diagram 1 Determination of the restricted lift due to reduced K_{dr}/α_w			2 Diagram 2 Determination of reduced K_{dr}/α_w or K_b ¹⁾ due to back pressure		
Step	Description	Sample	Step	Description	Sample
1	Calculate the required coefficient of discharge of the selected safety valve. Applicable formulars are stated in codes and standards.	1a $K_{dr}/\alpha_w = 0,45$	1	Calculate the back pressure ratio p_{a0}/p_0 using the actual values for set pressure p_0 [bar _a] 0,45 and back pressure p_{a0} [bar _a] 0,292	2a $p_{a0}/p_0 = 0,648$
2	Select the starting point (0,45) at the Y-axis of the diagram.		2	Select the starting point (0,648) at the X-axis of the diagram.	
3	Lay a horizontal line onto the ratio graph to identify the intersection point.		3	Lay a vertical line onto the ratio graph to identify the intersection point.	
4	Lay a vertical line to the X-axis to identify the ratio of lift / flow diameter (h/d_0).	1b $h/d_0 = 0,13$	4	Lay a horizontal line to the Y-axis to identify the reduced K_{dr}/α_w or K_b .	2b $K_{dr}/\alpha_w = 0,595$ $K_b = 0,85$
5	Calculate the restricted lift using the formular $h = d_0 \times h/d_0$. (For ordering a lift restriction please use option code J51 ref. to page 99/25)	$h = 23 \times 0,13$ $h = 3,0$ mm	5	Calculate the sizing with the established K_{dr}/α_w or K_b .	

Sample Capacity sheet –

How to select capacities for steam: Type 441, 442 Full nozzle DIN, DN 40

Capacities – Steam

Capacities for saturated steam according to AD 2000-Merkblatt A2, based on set pressure plus 10 % overpressure. **9**

Capacities at 1 bar (14,5 psig) and below are based on 0,1 bar (1,45 psig) overpressure.

Capacities for saturated steam according to ASME Section VIII (UV), based on set pressure plus 10% overpressure.

Capacities at 2,07 bar (30 psig) and below are based on 0,207 bar (3 psig) overpressure.

Metric Units		AD 2000-Merkblatt A2 [kg/h]		
DN		25	40	50
DN _o		40	65	80
Actual Orifice diameter d _o [mm]		23	37	46
Actual Orifice area A _o [mm ²]		416	1075	1662
LEO _{s/g} ^{*)} [inch ²]		0,462	1,195	1,847
Set pressure [bar]	Capacities [kg/h]			
0,1	0	0	0	
0,2	140	363	561	
0,5	224	579	895	
1	326	843	1302	

US Units		ASME Section VIII [lb/h]		
DN _i		25	40	50
DN _o		40	65	80
Actual Orifice diameter d _o [inch]		0,91	1,47	1,81
Actual Orifice area A _o [inch ²]		0,644	1,667	2,576
LEO _{s/g} ^{*)} [inch ²]		0,462	1,195	1,847
Set pressure [psig]	Capacities [lb/h]			
15	757	1959	3028	
20	873	2259	3492	
30	1105	2859	4419	
40	1360	3519	5439	

^{*)} LEO_{s/g} = LESER Effective Orifice steam/gas please refer to page 00/11

Explanation

Type 441, 442 Full nozzle DIN, DN 40

No.	Description		Metric Units	US Units	Example
1	Code				AD 2000-Merkblatt A2
2	Nominal diameter inlet	DN _i			40
3	Nominal diameter outlet	DN _o			65
4	Actual orifice diameter	d _o	[mm]	[inch]	37
5	Actual orifice area	A _o	[mm ²]	[inch ²]	1075
6	LESER Effective Orifice	LEO _{s/g}	[mm ²]	[inch ²]	1,195
7	Set pressure		[bar _g]	[psig]	1
8	Capacity		[kg/h]	[lb/h]	843
9	Base of calculation				see table page 00/10

9

Base of calculation

		Metric Units	US Units	
Code		Capacity calculation according to AD 2000-Merkblatt A2	Capacity calculation according to ASME Section VIII (UV)	
Media				
STEAM (saturated steam)	Standard conditions	Steam table IAPWS-IF97 IAPWS Industrial Formulation for the Thermodynamic Properties of Water and Steam	[kg/h]	Steam table IAPWS-IF97 IAPWS Industrial Formulation for the Thermodynamic Properties of Water and Steam
AIR	Standard conditions	0 °C and 1013 mbar	[m _n ³ /h]	16 °C (60 °F) [S.C.F.M.]
WATER	Standard conditions	20 °C (68 °F)	[10 ³ kg/h]	21 °C (70 °F) [US-G.P.M.]
All Media				
	Calculation pressure	Set pressure plus 10 % overpressure	Set pressure plus 10 % overpressure	
	Calculation pressure for low set pressure	Capacities at 1 bar (14,5 psig) and below are based on 0,1 bar (1,45 psig) overpressure.	Capacities at 2,07 bar (30 psig) and below are based on 0,207 bar (3 psig) overpressure.	

Example

Capacity calculation pressure

Metric Units		US Units	
Set pressure	Capacity calculation pressure	Set pressure	Capacity calculation pressure
10 bar	10 bar + 10% overpressure = 11 bar	145 psig	145 psig + 10% overpressure = 159,5 psig
0,5 bar	0,5 bar + 0,1 bar overpressure = 0,6 bar	20 psig	20 psig + 3 psig overpressure = 23 psig

6

LESER Effective Orifice

Pressure relief devices may be initially sized using the equations shown in API RP 520, sections 3.6 through 3.10 as appropriate for vapors, gases, liquids, or two phase flow. These equations utilize effective coefficient of discharge (S/G 0,975, L 0,650) and effective areas (acc. to API Std. 526, Fifth Edition, June 2002, table 1) which are independent of any specific

valve design. In this way the designer can determine a preliminary pressure relief valve size. By using the LESER Effective Orifice the designer can directly select a LESER safety relief valve after calculating the orifice letter. In this case, a verification of the sizing with the selected actual orifice and the rated coefficient of discharge is not necessary.

LEO_{S/G}	LESER Effective Orifice (for steam, gas and vapor)	[inch²]	refer to page 00/11
LEO_L	LESER Effective Orifice (for liquid)	[inch²]	refer to page 00/12

For further information refer to LESER Engineering Handbook

This table is based on the rated coefficient of discharge for steams and gases of LESER safety valves certified by ASME. The appropriated K-values are shown in the column "K-value" of the table.

$$LEO_{S/G} [\text{inch}^2] = A_0 [\text{inch}^2] \cdot \left(\frac{K}{0,975} \right)$$

LEO _{S/G}		LESER Effective Orifice (for steam, gas and vapor)							
Orifice acc. API 526	LESER-Series	DN	Inlet size	d ₀ [inch]	d ₀ [mm]	K-value	LEO _{S/G} [inch ²]	% of higher orifice	% of lower orifice
D							0,110	100,0%	100,0%
E							0,196	100,0%	100,0%
	458	25	1"	0,591	15,0	0,798	0,224	73,0%	114,4%
	441	20	3/4"	0,709	18,0	0,699	0,283	92,1%	114,3%
F							0,307	100,0%	100,0%
	458	25	1"	0,787	20,0	0,798	0,399	79,2%	129,8%
	441	25	1"	0,906	23,0	0,699	0,462	91,8%	150,4%
	441 Full nozzle	25	1"	0,906	23,0	0,699	0,462	91,8%	150,4%
	444	25	1"	0,906	23,0	0,699	0,462	91,8%	150,4%
G							0,503	100,0%	100,0%
	441	32	1 1/2"	1,142	29,0	0,699	0,734	93,5%	145,9%
	441 Full nozzle	32	1 1/2"	1,142	29,0	0,699	0,734	93,5%	145,9%
H							0,785	100,0%	100,0%
	458	50	2"	1,181	30,0	0,798	0,897	69,7%	114,2%
	441	40	1 1/2"	1,457	37,0	0,699	1,195	92,8%	152,2%
	441 Full nozzle	40	1 1/2"	1,457	37,0	0,699	1,195	92,8%	152,2%
	444	40	1 1/2"	1,457	37,0	0,699	1,195	92,8%	152,2%
J							1,287	100,0%	100,0%
	457, 458	50	2"	1,575	40,0	0,798	1,594	86,7%	123,9%
K							1,838	100,0%	100,0%
	441	50	2"	1,811	46,0	0,699	1,847	64,7%	100,5%
	441 Full nozzle	50	2"	1,811	46,0	0,699	1,847	64,7%	100,5%
	444	50	2"	1,811	46,0	0,699	1,847	64,7%	100,5%
	458	80	3"	1,969	50,0	0,798	2,491	87,3%	135,5%
	458	100	4"	1,969	50,0	0,798	2,491	87,3%	135,5%
L							2,853	100,0%	100,0%
	441	65	3"	2,362	60,0	0,699	3,142	87,3%	110,1%
	441 Full nozzle	65	3"	2,362	60,0	0,699	3,142	87,3%	110,1%
	444	65	2 1/2"	2,362	60,0	0,699	3,142	87,3%	110,1%
	458	80	3"	2,362	60,0	0,754	3,389	94,1%	118,1%
	458	100	4"	2,362	60,0	0,798	3,587	99,6%	125,7%
M							3,600	100,0%	100,0%
N							4,340	100,0%	100,0%
	441	80	-	2,913	74,0	0,699	4,779	74,9%	110,1%
	444	80	3"	2,913	74,0	0,699	4,779	74,9%	110,1%
	458	100	4"	2,913	74,0	0,798	5,456	85,5%	125,7%
P							6,380	100,0%	100,0%
	458	100	4"	3,465	88,0	0,754	7,290	66,0%	114,3%
	441	100	4"	3,622	92,0	0,699	7,387	66,9%	115,8%
	441 Full nozzle	100	4"	3,622	92,0	0,699	7,387	66,9%	115,8%
	441	125	5"	3,858	98,0	0,699	8,382	75,9%	131,4%
Q							11,050	100,0%	100,0%
	458	150	6"	4,331	110,0	0,754	11,391	71,2%	103,1%
	441	150	6"	4,921	125,0	0,699	13,637	85,2%	123,4%
R							16,000	100,0%	100,0%
	441	200	8"	6,496	165,0	0,699	23,761	91,4%	148,5%
	XXL	200	8"	6,496	165,0	0,699	23,761	91,4%	148,5%
T							26,000	100,0%	100,0%
	441 XXL	250	10"	7,874	200,0	0,699	34,910		134,3%
	441 XXL	300	12"	9,252	235,0	0,699	48,198		185,4%
	441 XXL	400	16"	11,614	295,0	0,699	75,952		292,1%

This table is based on the rated coefficient of discharge for liquids of LESER safety valves certified by ASME. The appropriated K-values are shown in the column "K-value" of the table.

$$LEO_L \text{ [inch}^2\text{]} = A_o \text{ [inch}^2\text{]} \cdot \left(\frac{K}{0,650} \right)$$

LEO_L		LESER Effective Orifice (for liquid)							
Orifice acc. API 526	LESER-Series	DN	Inlet size	d ₀ [inch]	d ₀ [mm]	K-value	LEO _L [inch ²]	% of higher orifice	% of lower orifice
D							0,110	100,0%	100,0%
E							0,196	100,0%	100,0%
F	458	25	1"	0,591	15	0,572	0,241	78,5%	123,0%
	441	20	3/4"	0,709	18	0,521	0,316	62,9%	103,0%
G	458	25	1"	0,787	20	0,572	0,429	85,2%	139,6%
	441	25	1"	0,906	23	0,521	0,516	65,8%	102,6%
H	441 Full nozzle	25	1"	0,906	23	0,521	0,516	65,8%	102,6%
	444	25	1"	0,906	23	0,521	0,516	65,8%	102,6%
	458	50	1"	1,181	30	0,572	0,964	74,9%	122,8%
J	441	40	1 1/2"	1,457	37	0,521	1,336	72,7%	103,8%
	441 Full nozzle	40	1 1/2"	1,457	37	0,521	1,336	72,7%	103,8%
	444	40	1 1/2"	1,457	37	0,521	1,336	72,7%	103,8%
	458	50	2"	1,575	40	0,572	1,714	93,3%	133,2%
K	441	50	2"	1,811	46	0,521	2,065	72,4%	112,3%
	441 Full nozzle	50	2"	1,811	46	0,521	2,065	72,4%	112,3%
	444	50	2"	1,811	46	0,521	2,065	72,4%	112,3%
	458	80	3"	1,969	50	0,527	2,678	93,9%	145,7%
	458	100	4"	1,969	50	0,527	2,678	93,9%	145,7%
L	458	80	3"	2,362	60	0,479	3,230	89,7%	113,2%
	441	65	3"	2,362	60	0,521	3,513	97,6%	123,1%
	441 Full nozzle	65	3"	2,362	60	0,521	3,513	97,6%	123,1%
	444	65	2 1/2"	2,362	60	0,521	3,513	97,6%	123,1%
M	458	100	4"	2,362	60	0,572	3,857	88,9%	107,1%
	441	80	-	2,913	74	0,521	5,343	83,3%	123,1%
N	444	80	3"	2,913	74	0,521	5,343	83,3%	123,1%
	458	100	4"	2,913	74	0,572	5,866	91,9%	135,2%
	458	100	4"	3,465	88	0,479	6,947	62,9%	108,9%
P	441	100	4"	3,622	92	0,521	8,259	74,7%	129,4%
	441 Full nozzle	100	4"	3,622	92	0,521	8,259	74,7%	129,4%
	441	125	5"	3,858	98	0,521	9,371	84,8%	146,9%
	458	150	6"	4,331	110	0,479	10,855	98,2%	170,1%
	441	150	6"	4,921	125	0,521	15,246	95,3%	138,0%
Q							11,050	100,0%	100,0%
R							16,000	100,0%	100,0%
T	441	200	8"	6,496	165	0,521	26,565		102,0%
	441 XXL	200	8"	6,496	165	0,521	39,031		102,0%
	441 XXL	250	10"	7,874	200	0,521	39,031		150,1%
	441 XXL	300	12"	9,252	235	0,521	53,887		207,3%
	441 XXL	400	16"	11,614	295	0,521	84,916		326,6%

Sour gas service (H₂S)

LESER

Normative basis

In accordance with NACE standard MR 0175-2003 sour gas service means the presence of H₂S in the following conditions:

Part 1.4.1.1.: All gas, gas condensate, and sour crude oil – When the partial pressure of H₂S in a wet (water as a liquid) gas phase of a gas, gas condensate, or crude oil system is equal to or exceeds 0,003 bar_a (0,05 psia)

Exceptions are:

Part 1.4.2.1.: **Low-pressure gas:** When the total pressure is lower than 4,5 bar_a (65 psia)

Part 1.4.2.2.: **Low-pressure oil and gas multiphase systems:** ...

Other Sour gas standards:

NACE MR 0103-2003: Materials resistance to sulfide stress cracking in corrosive petroleum refining environments.

DIN EN ISO 15156-1: Petroleum and natural gas industries – Materials for use in H₂S-containing environments in oil and gas production – Part 1: General principles for selection of cracking-resistant materials (ISO 15156-1:2001)

Miscellaneous

Workstandards: Please refer to LWN 001.91

General requirements for sour gas service





The above mentioned standards require a maximum hardness of 22 HRC for the most steels.

For the actual requirements of a specific material please refer to the applied standard.

LESER sour gas level

General: Sour gas material requirements must be fulfilled if pressure and partial pressure conditions according to the applied standard exist.

Based on these general statement LESER defines two sour gas level for safety valves:

Part definition	Level 1		Level 2	
	Contact with the medium in closed position		Contact with the medium in opened position	
	Conventional	Balanced bellows	Conventional	Balanced bellows
Contact area				
Pressure requirements	Set pressure ≥ 4,5 bar _a (65 psia)		Back pressure ≥ 4,5 bar _a (65 psia)	
Safety valve operation	closed		closed / opened	
Parts concerned	Conventional design	Body / Nozzle Disc	All	
	Balanced bellows design	Body / Nozzle Disc	Body / Nozzle Disc Bonnet spacer Bellows	

Necessary material modification

Type	Body material	Design	Part	Material	Option code	Material	Option code	
4412 DIN 4412 ANSI 4412 Full nozzle DIN 4412 Full nozzle ANSI	1.0619 (WCB)	Conventional	Disc	1.4404 / 316L	L44	Please choose balanced bellows design		
4414 DIN 4414 ANSI 4414 Full nozzle DIN 4414 Full nozzle ANSI		1.4408 (CF8M)	Balanced bellows	Disc	1.4404 / 316L	L44	1.4404 / 316L	L44
			Balanced bellows	Bellows	1.4571 / 316Ti	J78	1.4571 / 316Ti	J78
4412 XXL	1.0460 / 1.0425 (Carbon steel)	Conventional	Disc	No modification required		Please choose balanced bellows design		
		Balanced bellows	Disc	No modification required		No modification required		
			Bellows	1.4571 / 316Ti	J78	1.4571 / 316Ti	J78	
4414 XXL	1.4571 (316Ti)	Conventional		No modification required		No modification required		
		Balanced bellows	Bellows	1.4571 / 316Ti	J78	1.4571 / 316Ti	J78	
4444 DIN 4444 ANSI	1.4404 (316L)	Conventional		No modification required		No modification required		
4562, 4582 4587	1.0619 (WCB) 1.7357 (WC6)	Conventional	Disc	1.4404 / 316L	L44	Please choose balanced bellows design		
		Balanced bellows	Disc	1.4404 / 316L	L44	1.4404 / 316L	L44	
			Bellows	1.4571 / 316Ti	J78	1.4571 / 316Ti	J78	
4584	1.4581 (CF10M)	Conventional		Not listed in NACE		Not listed in NACE		
		Balanced bellows		Not listed in NACE		Not listed in NACE		



Type 442 Full nozzle DIN
Plain lever H3
Open bonnet
Conventional design



Type 441 Full nozzle DIN
Packed lever H4
Closed bonnet
Conventional design

Type

441, 442

Full nozzle DIN

**Flanged Safety Relief Valves
– spring loaded**

Contents	Chapter/Page
Materials	
• Conventional design	06/02
• Balanced bellows design	06/04
How to order	
• Numbering system	06/06
• Article numbers	06/08
Dimensions and weights	
• Metric Units	06/10
• US Units	06/11
Pressure temperature ratings	
• Metric Units	06/12
• US Units	06/13
Flange drillings and facings	06/14
Order information – Spare parts	06/15
Available options	06/16
Approvals	06/17
Capacities	
• Steam [Metric Units + US Units]	06/18
• Air [Metric Units + US Units]	06/19
• Water [Metric Units + US Units]	06/20
Determination of coefficient of discharge K_{dr}/α_w	06/21

Type 441, 442 Full Nozzle DIN **LESER**

Conventional design

Type 441, 442 Full nozzle DIN

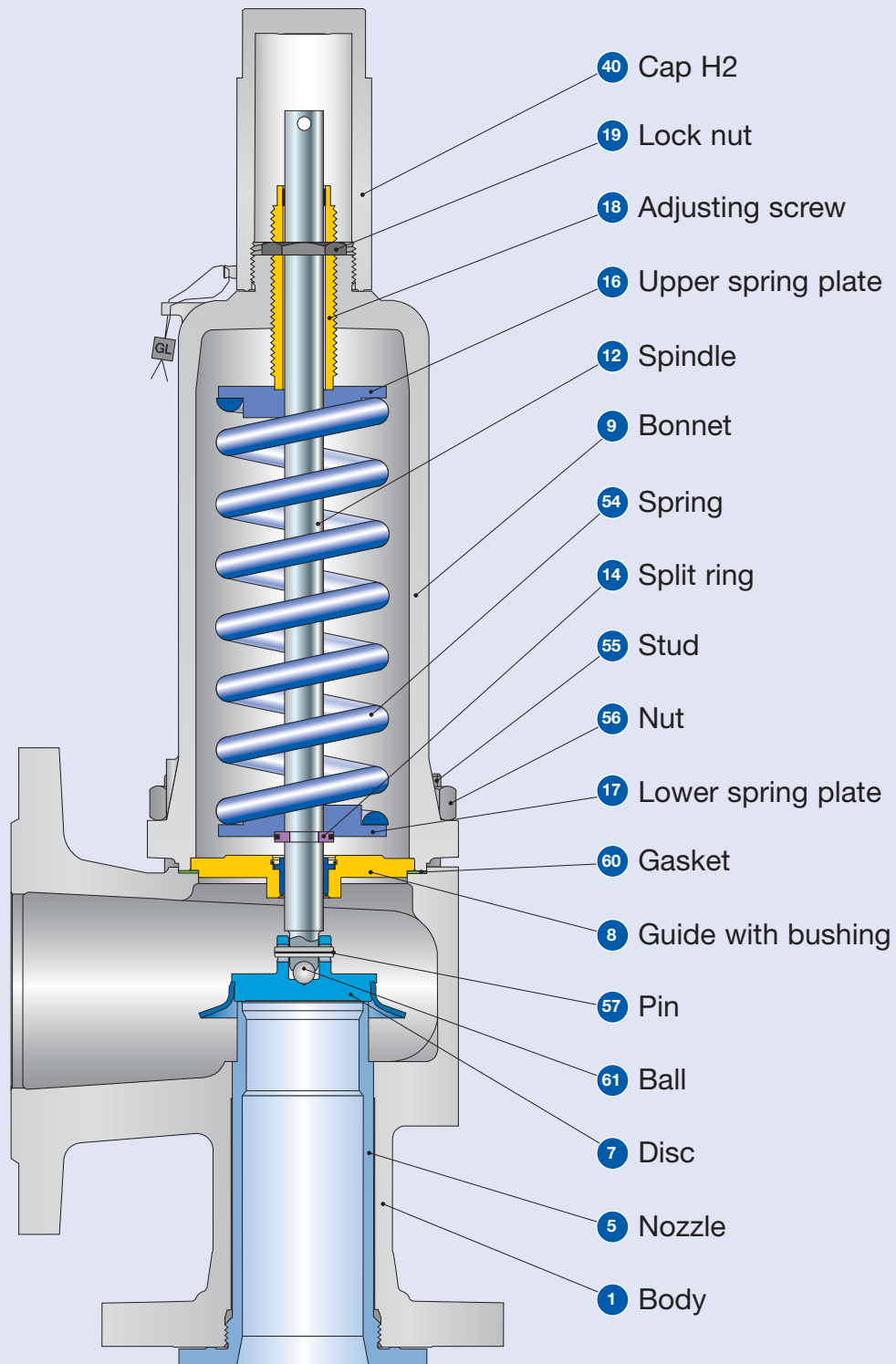

Type 441, 442 Full Nozzle DIN **LESER**

Conventional design

Materials			
Item	Component	Type 4412 / 4422 Full nozzle DIN	Type 4414 Full nozzle DIN
1	Body	1.0619	1.4408
		SA 216 WCB	SA 351 CF8M
5	Nozzle	1.4404	1.4404
		316L	316L
7	Disc	1.4122	1.4404
		Hardened stainless steel	316L
8	Guide with bushing	1.0501	1.4404
		Carbon steel	316L
		1.4104 tenifer	-
		Chrome steel	-
9	Bonnet	0.7040, 0.7043, 1.0619	1.4408 or 1.4571
		Ductile Gr. 60-40-18, SA 216 WCB	SA CF8M or SA 479 316Ti
12	Spindle	1.4021	1.4404
		420	316L
14	Split ring	1.4104	1.4404
		Chrome steel	316L
16 / 17	Spring plate	1.0718	1.4404
		12L13	316L
18	Adjusting screw with bushing	1.4104 PTFE	1.4404
		Chrome steel PTFE	316L PTFE
19	Lock nut	1.0718	1.4404
		Steel	316L
40	Cap H2	1.0718	1.4404
		12L13	316L
54	Spring standard	1.1200, 1.8159, 1.7102	1.4310
		Carbon steel	Stainless steel
	Spring optional	1.4310	-
55	Stud	1.1181	1.4401
		Steel	B8M
56	Nut	1.0501	1.4401
		2H	8M
57	Pin	1.4310	1.4310
		Stainless steel	Stainless steel
60	Gasket	Graphite / 1.4401	Graphite / 1.4401
		Graphite / 316	Graphite / 316
61	Ball	1.3541	1.4401
		Hardened stainless steel	316

Please notice:

- Modifications reserved by LESER.
- LESER can upgrade materials without notice.
- Every part can be replaced by other material acc. to customer specification.

Type 441, 442 Full nozzle DIN **LESER**

Balanced bellows design

Type 441, 442 Full nozzle DIN

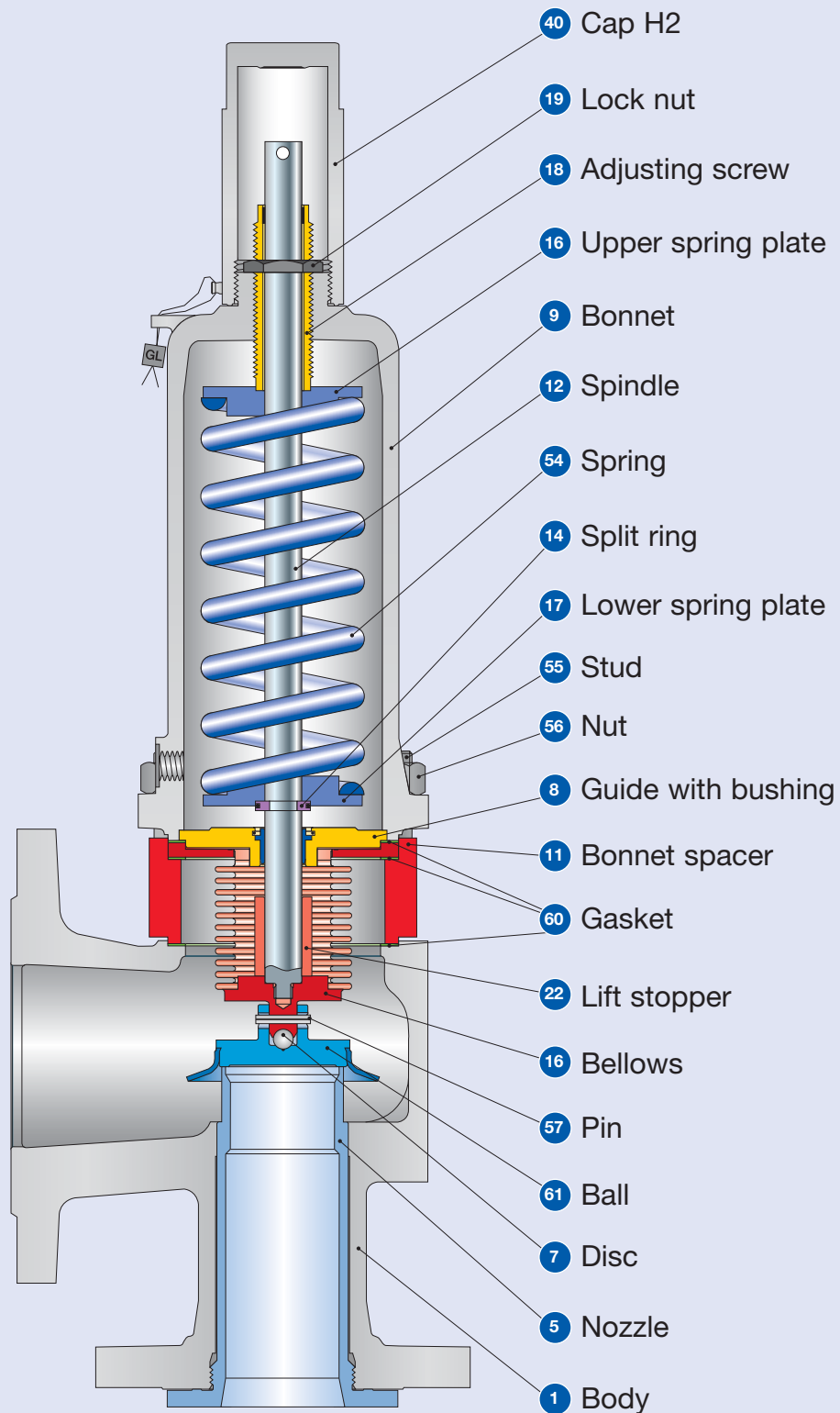

Type 441, 442 Full nozzle DIN **LESER**

Balanced bellows design

Materials		Type 4412 / 4422 Full nozzle DIN	Type 4414 Full nozzle DIN
1	Body	1.0619	1.4408
		SA 216 WCB	SA 351 CF8M
5	Nozzle	1.4404	1.4404
		316L	316L
7	Disc	1.4122	1.4404
		Hardened stainless steel	316L
8	Guide with bushing	1.0501	1.4404
		Carbon steel	316L
		1.4104 tenifer	-
		Chrome steel	-
9	Bonnet	0.7040, 0.7043, 1.0619	1.4408 or 1.4571
		Ductile Gr. 60-40-18, SA 216 WCB	SA 351 CF8M or SA 479 316Ti
11	Bonnet spacer	1.0460	1.4404
		Carbon steel	316L
12	Spindle	1.4404	1.4404
		316L	316L
14	Split ring	1.4104	1.4404
		Chrome steel	316L
15	Bellows	1.4571	1.4571
		316Ti	316Ti
16 / 17	Spring plate	1.0718	1.4404
		12L13	316L
18	Adjusting screw with bushing	1.4104 PTFE	1.4404
		Chrome steel PTFE	316L PTFE
19	Lock nut	1.0718	1.4404
		Steel	316L
22	Lift stopper	1.4404	1.4404
		316L	316L
40	Cap H2	1.0718	1.4404
		12L13	316L
54	Spring standard	1.1200, 1.8159, 1.7102	1.4310
		Carbon steel	Stainless steel
	Spring optional	1.4310	-
		Stainless steel	-
55	Stud	1.4401	1.4401
		B8M	B8M
56	Nut	1.4401	1.4401
		8M	8M
57	Pin	1.4310	1.4310
		Stainless steel	Stainless steel
60	Gasket	Graphite / 1.4401	Graphite / 1.4401
		Graphite / 316	Graphite / 316
61	Ball	1.3541	1.4401
		Hardened stainless steel	316

Please notice:

- Modifications reserved by LESER.
- LESER can upgrade materials without notice.
- Every part can be replaced by other material acc. to customer specification.

Type 441, 442 Full nozzle DIN **LESER**

How to order – Numbering system

1

Article Number

1	2	3	4
441	2	057	2

1 Valve Type 441, 442 Full nozzle DIN

Type 441 – with closed bonnet
Type 442 – with open bonnet

2 Material code

Code	Body material
2	1.0619 (WCB)
4	1.4408 (CF8M)

3 Valve code

Identifies valve size and body material, refer to page 06/09.

4

Code	Lifting lever	
2	screwed cap	H2
3	plain lever	H3
4	packed lever	H4
5	plain lever with open bonnet	H3

4412.0572

Article No.

2

Set Pressure

Please state unit (in gauge)!

Please do not exceed the pressure range defined in the spring charts.

5 bar_g

Set Pressure

3

Connections

Please refer to page 06/14

H64

Connections

4

Options

Type 441, 442 Full nozzle DIN

	Option code
• O-ring-disc	
CR "K"	J21
EPDM "D"	J22
FKM "L"	J23
FFKM "C"	J20
• Disc 1.4404 / 316L	L44
• Disc 1.4404 / 316L stellited	J25
• Detachable lifting aid	J26
• Stainless steel bellows	
- open bonnet (Type 442)	J68
- closed bonnet (Type 441)	J78
• Elastomer bellows	J79
• High temperature alloy spring	X01
• Stainless steel spring	X04
• Adaptor for lift indicator H4	J39
• Lift indicator	J93
• Test gag	
- cap H2	J70
- packed lever H4	J69
• Nozzle 316L stellited	L62
• Heating jacket	
- Couplings G 3/8	H29
G 3/4	H30
- Flanges DN 15	H31
DN 25	H32
• Drain hole G 1/4	J18
G 1/2	J19
• Free of oil and grease	J85
• Materials	
- NACE	H01

Option code applies only if not standard

J22

Options

5

Documentation

Please select requested documentation:

Inspections, tests: Option code
DIN EN 10204-3.2: TÜV-Nord
Certificate for test pressure **M33**

LESER Certificate for Global Application **H03**
- Inspection certificate 3.1 acc. to DIN EN 10204
- Declaration of conformity acc. to PED 97/23/EC

Material test certificate:
DIN EN 10204-3.1

Part	Option code
Body	H01
Nozzle	L59
Bonnet	L30
Cap / lever cover	L31
Disc	L23
Studs	N07
Nuts	N08

H01

L30

Documentation

6

Code and Medium

1	2
2	0

1 Code
1. ASME Section VIII
2. CE / VdTUEV
3. ASME Section VIII + CE / VdTUEV

2 Medium
.1 Gases
.2 Liquids
.3 Steam
.0 Steam / Gases / Liquids (valid only for CE / VdTUEV)

2.0

Code and Medium

Type 441, 442 Full nozzle DIN **LESER**

How to order – Article numbers

Type 441, 442 Full nozzle DIN

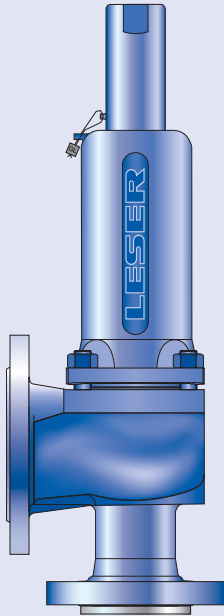

Type 441 Full nozzle
Cap H2
Closed bonnet
Conventional design

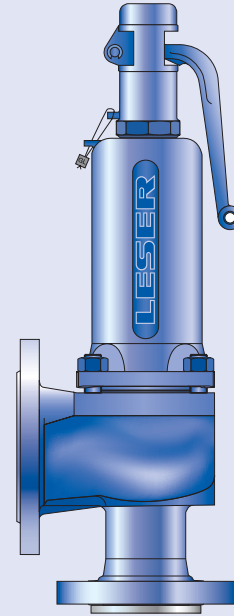

Type 441 Full nozzle
Plain lever H3
Closed bonnet
Conventional design

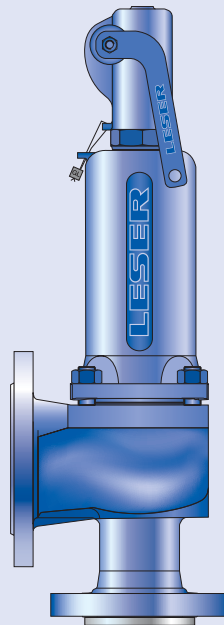

Type 441 Full nozzle
Packed lever H4
Closed bonnet
Conventional design

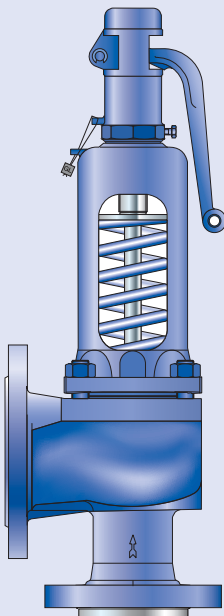

Type 442 Full nozzle
Plain lever H3
Open bonnet
Conventional design

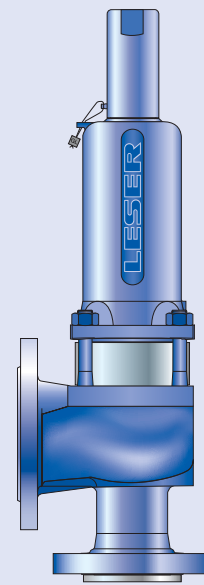

Type 441 Full nozzle
Cap H2
Closed bonnet
Balanced bellows design

Type 441, 442 Full nozzle DIN **LESER**

How to order – Article numbers

Article numbers					
	DN _i		25	40	50
	DN _o		40	65	80
	Actual Orifice diameter d ₀ [mm]		23	37	46
	Actual Orifice area A ₀ [mm ²]		416	1075	1662
Body material: 1.0619 (WCB)					
Bonnet	H2	Art.-No. 4412.	0572	0582	0592
closed	H3	Art.-No. 4412.	0573	0583	0593
	H4	Art.-No. 4412.	0574	0584	0594
open	H3	Art.-No. 4422.	0575	0585	0595
Body material: 1.4408 (CF8M)					
Bonnet	H2	Art.-No. 4414.	0952	0962	0972
closed	H4	Art.-No. 4414.	0954	0964	0974

For sizes DN 80/3" and above please select Series 526 valves, DIN drilled or 441 Full nozzle ANSI, DIN drilled.

Type 441, 442 Full nozzle DIN **LESER**

Dimensions and weights

Metric Units

	DN _i	25	40	50
	DN _o	40	65	80
	Actual Orifice diameter d ₀ [mm]	23	37	46
	Actual Orifice area A ₀ [mm ²]	416	1075	1662
Weight				
[kg]		9	16	22
	with bellows	10	17	24
Center to face				
[mm]	Inlet a	111	143,5	154
	Outlet b	100	115	120
Height (H4)				
[mm]	Standard H max.	345	515,5	573
	Bellows H max.	384	553,5	619
Body material: 1.0619 (WCB)				
DIN Flange¹⁾				
	Inlet		PN 40 or 16	
	Outlet		PN 16	
Body material: 1.4408 (CF8M)				
DIN Flange¹⁾				
	Inlet		PN 40 or 16	
	Outlet		PN 16	

¹⁾ Standard flange rating. For other flange drillings and facings please refer to page 06/14.

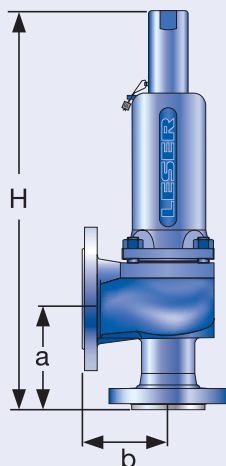

Conventional design

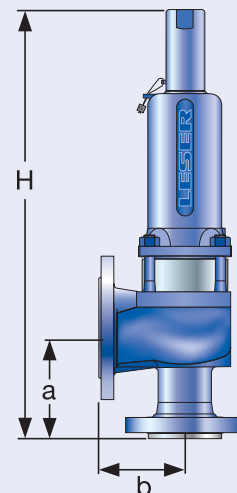

Balanced bellows design

Type 441, 442 Full nozzle DIN **LESER**

Dimensions and weights

US Units				
	DN _i	25	40	50
	DN _o	40	65	80
	Actual Orifice diameter d _o [inch]	0,91	1,46	1,81
	Actual Orifice area A _o [inch ²]	0,644	1,667	2,576
Weight				
[lbs]		20	35	49
	with bellows	21	38	52
Center to face	Inlet a	4 3/8	5 5/8	6 1/16
[inch]	Outlet b	3 15/16	4 1/2	4 3/4
Height (H4)	Standard H max.	9 3/16	13	14 5/8
[inch]	Bellows H max.	10 11/16	14	16 1/8
Body material: 1.0619 (WCB)				
DIN Flange¹⁾	Inlet		PN 40 or 16	
	Outlet		PN 16	
Body material: 1.4408 (CF8M)				
DIN Flange¹⁾	Inlet		PN 40 or 16	
	Outlet		PN 16	

¹⁾ Standard flange rating. For other flange drillings and facings please refer to page 06/14.



Type 441, 442 Full nozzle DIN **LESER**

Pressure temperature ratings

Metric Units

DN _i	25	40	50
DN _o	40	65	80
Actual Orifice diameter d ₀ [mm]	23	37	46
Actual Orifice area A ₀ [mm ²]	416	1075	1662

Body material: 1.0619 (WCB)

DIN Flange	Inlet		PN 40 or 16		
	Outlet		PN 16		
Minimum set pressure	p [bar _g]	S/G/L	0,1	0,1	0,1
Min. set pressure¹⁾ standard bellows	p [bar _g]	S/G/L	3	3	3
Min. set pressure low press. bellows	p [bar _g]	S/G/L	0,98	1,11	1,81
Maximum set pressure	p [bar _g]	S/G/L	40	40	40
Max. set pressure with special spring	p [bar _g]	S/G/L	40	40	40
Temperature acc. to DIN EN	min. [°C]		-85		
	max. [°C]		+450		
Temperature acc. to ASME	min. [°C]		-29		
	max. [°C]		+427		

Body material: 1.4408 (CF8M)

DIN Flange	Inlet		PN 40 or 16		
	Outlet		PN 16		
Minimum set pressure	p [bar _g]	S/G/L	0,1	0,1	0,1
Min. set pressure¹⁾ standard bellows	p [bar _g]	S/G/L	3	3	3
Min. set pressure low press. bellows	p [bar _g]	S/G/L	0,98	1,11	1,81
Maximum set pressure	p [bar _g]	S/G/L	40	40	33
Max. set pressure with special spring	p [bar _g]	S/G/L	40	40	37
Temperature acc. to DIN EN	min. [°C]		-270		
	max. [°C]		+400		
Temperature acc. to ASME	min. [°C]		-268		
	max. [°C]		+538		

¹⁾ Min. set pressure standard bellows = Max. set pressure low pressure bellows.

Type 441, 442 Full nozzle DIN **LESER**

Pressure temperature ratings

US Units				
	DN _i	25	40	50
	DN _o	40	65	80
	Actual Orifice diameter d _o [inch]	0,91	1,46	1,81
	Actual Orifice area A _o [inch ²]	0,644	1,667	2,576
Body material: 1.0619 (WCB)				
DIN Flange	Inlet	PN 40 or 16		
	Outlet	PN 16		
Minimum set pressure	p [psig] S/G/L	1,5	1,5	1,5
Min. set pressure¹⁾ standard bellows	p [psig] S/G/L	43,5	43,5	43,5
Min. set pressure low press. bellows	p [psig] S/G/L	14	16	26
Maximum set pressure	p [psig] S/G/L	580	580	580
Max. set pressure with special spring	p [psig] S/G/L	580	580	580
Temperature acc. to DIN EN	min. [°F]	-121		
	max. [°F]	+842		
Temperature acc. to ASME	min. [°F]	-20		
	max. [°F]	+800		
Body material: 1.4408 (CF8M)				
DIN Flange	Inlet	PN 40 or 16		
	Outlet	PN 16		
Minimum set pressure	p [psig] S/G/L	1,5	1,5	1,5
Min. set pressure¹⁾ standard bellows	p [psig] S/G/L	43,5	43,5	43,5
Min. set pressure low press. bellows	p [psig] S/G/L	14	16	26
Maximum set pressure	p [psig] S/G/L	580	580	479
Max. set pressure with special spring	p [psig] S/G/L	580	580	537
Temperature acc. to DIN EN	min. [°F]	-454		
	max. [°F]	+752		
Temperature acc. to ASME	min. [°F]	-450		
	max. [°F]	+1000		

¹⁾ Min. set pressure standard bellows = Max. set pressure low pressure bellows.

Type 441, 442 Full nozzle DIN **LESER**

Flange drillings and facings

Flange drillings

	DN _i	25	40	50	
	DN _o	40	65	80	
	Actual Orifice diameter d _o [mm]	23	37	46	
	Actual Orifice area A _o [mm ²]	416	1075	1662	
Body material: 1.0619 (WCB), 1.4408 (CF8M)					
Inlet	DIN EN 1092	PN 10	*	*	*
		PN 16	*	*	*
		PN 25	*	*	*
		PN 40	*	*	*
	ASME B16.5	CL150	Please use 441, 442 Full nozzle ANSI		
		CL300	Please use 441, 442 Full nozzle ANSI		
Outlet	DIN EN 1092	PN 10	*	*	*
		PN 16	*	*	*
		PN 25	*	(H15)	(*)
		PN 40	*	(H15)	(*)
	ASME B16.5	CL150	Please use 441, 442 Full nozzle ANSI		
		CL300	Please use 441, 442 Full nozzle ANSI		

Flange facings

Indication	Standard	Nozzle	Outlet	Remark						
General										
Flange undrilled	–	H38	H39							
Linde-V-Nut, Form V48	Linde Standard 420-08	–	J08	Groove: Rz 16						
Linde-V-Nut, Form V48A	LWN 313.36	–	J06	Groove: Rz 4, e.g. with hydrogen						
Lens seal form L (without sealing lens)	DIN 2696 LWN 313.35	L57	J12							
Acc. to DIN EN										
Flange facing			Inlet	Outlet	Remark					
DIN EN 1092 (new)		DIN 2526 (old)			Rz-data according to DIN EN 1092 in µm					
(see also LWN 313.40)			PN 10 – PN 40	PN 10 – PN 40						
Raised face	Type B1	Type C	*	*	Facing: Rz = 12,5 – 50					
		Type D								
	Type B2	Type E	–	L38		Facing: Rz = 3,2 – 12,5				
Tongue face C ¹⁾		Tongue face F	L56	H92	Steel flanges only					
Groove face D ¹⁾		Groove face N	L55	H91						
Male face E		Male face V13	I90	H98						
Female face F		Female face R13	I91	H99						
O-ring male face G		Male face V14	I93	J02						
O-ring female face H		Female face R14	I92	J04						
Acc. to ASME B16.5										
Body material	Inlet	Outlet	Smooth finish ²⁾			RTJ-groove				
			Inlet	Outlet	Inlet	Outlet	Inlet		Outlet	
			Option code		Option code		RTJ-Class	Option code	RTJ-Class	Option code
1.0619, 1.4408	all	all	L52	L53	*	*	CL150, CL300	L58	CL150	H63

¹⁾ According to DIN EN 1092 groove depths and tongue heights increased compared to the formerly valid DIN (refer to LWN 313.40).

LESER manufactures the groove at flanged valves by milling. If a customer demands a turned surface in the soil of the groove according to DIN 2512 and/or DIN EN 1092-1 an additional option code is necessary: "S01: bottom of the groove drilled". Groove and tongue for PN160 flanges refer to DIN 2512/LWN 313.32.

²⁾ Smooth finish is not defined in the effective standards. For LESER's definition for smooth finish see page 00/07.

For signs and symbols refer to page 00/07

Note: Flange drillings and facings meet always the requirements of mentioned flange standards. Flange thickness and outer diameter may vary from flange standard.

Type 441, 442 Full nozzle DIN **LESER**

Order information – Spare parts

Spare parts				
	DN _i	25	40	50
	DN _o	40	65	80
	Actual Orifice diameter d ₀ [mm]	23	37	46
	Actual Orifice area A ₀ [mm ²]	416	1075	1662
Disc (Item 7): Metal to metal seat		Material-No. / Art.-No.		
Disc	1.4122	200.9739.9000	200.9939.9000	200.8739.9000
detachable lifting aid	1.4404	200.9749.9000	200.9949.9000	200.8749.9000
Disc (Item 7): Soft seal		Material-No. / Art.-No.		
Disc	CR “K”	200.5049.9051	200.5249.9051	200.5349.9051
	EPDM “D”	200.5049.9041	200.5249.9041	200.5349.9041
	FKM “L”	200.5049.9071	200.5249.9071	200.5349.9071
	FFKM “C”	200.5049.9091	502.0408.3591	502.0503.3591
Disc (Item 7.4): Soft seal		Material-No. / Art.-No.		
O-ring	CR “K”	502.0249.3551	502.0408.3551	502.0503.3551
	EPDM “D”	502.0249.3541	502.0408.3541	502.0503.3541
	FKM “L”	502.0249.3571	502.0408.3571	502.0503.3571
	FFKM “C”	502.0249.3591	502.0408.3591	502.0503.3591
Bellows (Item 15) 1.4571		Material-No. / Art.-No.		
Standard bellows		400.0949.0000	400.1149.0000	400.1249.0000
Conversion kit standard¹⁾		5021.1041	5021.1043	5021.1044
Low pressure bellows		400.0949.0021	400.1149.0021	400.1249.0021
Conversion kit low pressure¹⁾			please specify in writing	
Gasket – body / bonnet (Item 60)		Material-No. / Art.-No.		
Gasket	Graphite + 1.4401	500.0607.0000	500.1007.0000	500.1207.0000
Option code L68	Gylon (filled PTFE)	500.0605.0000	500.1005.0000	500.1205.0000
Ball (Item 61)		Material-No. / Art.-No.		
Ball	Ball Ø [mm]	6	9	9
	1.4404	510.0104.0000	510.0204.0000	510.0204.0000
Split ring (Item 14)		Material-No. / Art.-No.		
Split ring	Spindle Ø [mm]	12	16	16
	1.4404	251.0149.0000	251.0249.0000	251.0249.0000
Pin (Item 57)		Material-No. / Art.-No.		
Pin	1.4310	480.0505.0000	480.0705.0000	480.0705.0000

¹⁾ For pressure range see page 06/12 – 06/13.
A conversion kit contains the following components:

Item	Component	No.
8	Guide	1
11	Bonnet spacer	1
12	Spindle	1
15	Bellows	1
55	Stud	4
60	Gasket	2, 3 depends on valve size
	Installation instruction LWN 037.05	1

Refer to page 06/04

Type 441, 442 Full nozzle DIN **LESER**

Available Options

For further information refer to
"Accessories and Options", page 99/01

Heating jacket

H29, H30: Couplings G $\frac{3}{8}$, G $\frac{3}{4}$
H31, H32: Flanges DN 15, DN 25

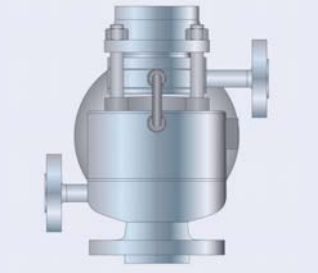

Drain hole

J18: G $\frac{1}{4}$
J19: G $\frac{1}{2}$

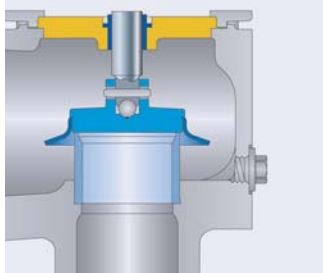

Open bonnet

See Art.-No.



O-ring-disc

J20: FFKM "C"
J21: CR "K"
J22: EPDM "D"
J23: FKM "L"

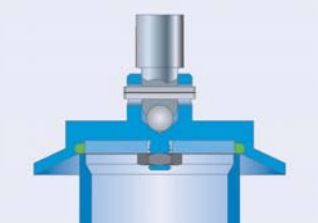

Disc with inserted sealing plate

J44: PTFE-FDA
J48: PCTFE
J49: SP

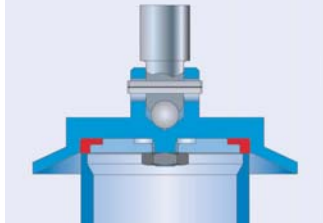

Stainless steel bellows

J68: Open bonnet
J78: Closed bonnet

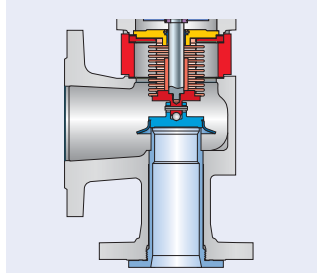

Conversion kit for stainless steel bellows

See Art.-No. page 06/15

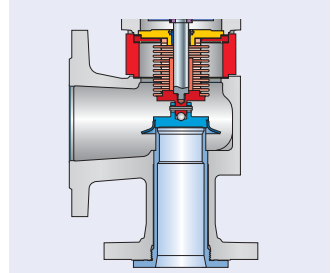

Screwed cap H2



Plain lever H3



Packed lever H4

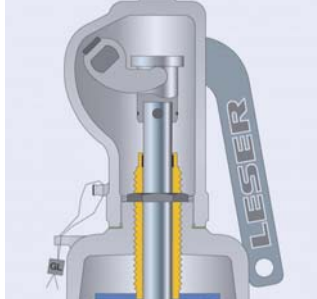

Test gag

J69: H4
J70: H2

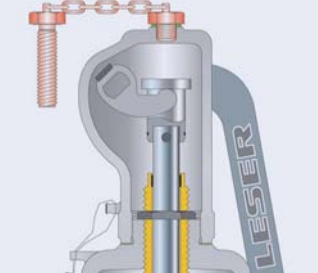

Lift indicator

J39: Adaptor H4
J93: Lift indicator

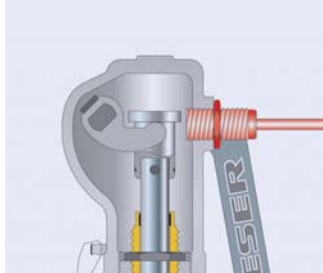

O-ring-damper H2

J65



O-ring-damper H4

J66



Type 441, 442 Full nozzle DIN **LESER**

Approvals

Approvals				
	DN _i	25	40	50
	DN _o	40	65	80
	Actual Orifice diameter d ₀ [mm]	23	37	46
	Actual Orifice area A ₀ [mm ²]	416	1075	1662
Europe		Coefficient of discharge K_{dr}		
DIN EN ISO 4126-1	Approval No.	072020111Z0008/0/08-2		
	S/G	0,7		
	L	0,45		
Germany		Coefficient of discharge α_w		
AD 2000-Merkblatt A2	Approval No.	TÜV SV 576		
	S/G	0,7		
	L	0,45		
United States		Coefficient of discharge K		
ASME Sec. VIII	Approval No.	M37044		
	S/G	0,699		
	Approval No.	M37055		
	L	0,521		
Canada		Coefficient of discharge K		
Canada: CRN	Approval No.	OG1182.9C		
	S/G	0,699		
	L	0,521		
China		Coefficient of discharge α_w		
CSBQTS	Approval No.			
	S/G	0,7		
	L	0,45		
Russia		Coefficient of discharge α_w		
		on request		
Belarus		Coefficient of discharge α_w		
PROMATOMNADZOR	Approval No.	15-171-2006		
	S/G	0,7		
	L	0,45		
Classification societies		on request		

Type 441, 442 Full nozzle DIN **LESER**

Capacities – Steam

Capacities for saturated steam according to AD 2000-Merkblatt A2, based on set pressure plus 10 % overpressure.

Capacities at 1 bar (14,5 psig) and below are based on 0,1 bar (1,45 psig) overpressure.

Metric Units		AD 2000-Merkblatt A2 [kg/h]		
	DN _i	25	40	50
	DN _o	40	65	80
	Actual Orifice diameter d ₀ [mm]	23	37	46
	Actual Orifice area A ₀ [mm ²]	416	1075	1662
	LEO _{S/G} *) [inch ²]	0,462	1,195	1,847
Set pressure [bar]	Capacities [kg/h]			
0,1	0	0	0	
0,2	140	363	561	
0,5	224	579	895	
1	326	843	1302	
2	519	1343	2075	
3	699	1808	2794	
4	871	2254	3485	
5	1043	2699	4172	
6	1214	3142	4856	
7	1381	3574	5525	
8	1551	4014	6205	
9	1721	4454	6884	
10	1891	4893	7562	
12	2230	5770	8919	
14	2562	6629	10247	
16	2900	7505	11600	
18	3239	8382	12955	
20	3578	9260	14312	
22	3907	10111	15629	
24	4247	10991	16988	
26	4588	11873	18351	
28	4930	12757	19718	
30	5272	13644	21089	
32	5616	14534	22465	
34	5945	15384	23779	
36	6290	16278	25160	
38	6637	17175	26547	
40	6985	18076	27939	

Capacities for saturated steam according to ASME Section VIII (UV), based on set pressure plus 10% overpressure.

Capacities at 2,07 bar (30 psig) and below are based on 0,207 bar (3 psig) overpressure.

US Units		ASME Section VIII [lb/h]		
	DN _i	25	40	50
	DN _o	40	65	80
	Actual Orifice diameter d ₀ [inch]	0,91	1,46	1,81
	Actual Orifice area A ₀ [inch ²]	0,644	1,667	2,576
	LEO _{S/G} *) [inch ²]	0,462	1,195	1,847
Set pressure [psig]	Capacities [lb/h]			
15	757	1959	3028	
20	873	2259	3492	
30	1105	2859	4419	
40	1360	3519	5439	
50	1615	4179	6459	
60	1870	4839	7479	
70	2125	5499	8499	
80	2380	6159	9519	
90	2635	6819	10539	
100	2890	7479	11559	
120	3400	8799	13600	
140	3910	10118	15640	
160	4420	11438	17680	
180	4930	12758	19720	
200	5440	14078	21760	
220	5950	15398	23800	
240	6460	16718	25840	
260	6970	18038	27880	
280	7480	19358	29920	
300	7990	20677	31960	
320	8500	21997	34000	
340	9010	23317	36040	
360	9520	24637	38080	
380	10030	25957	40120	
400	10540	27277	42161	
420	11050	28597	44201	
440	11560	29917	46241	
460	12070	31236	48281	
480	12580	32556	50321	
500	13090	33876	52361	
550	14365	37176	57461	
580	15130	39156	60521	

*) LEO_{S/G} = LESER Effective Orifice steam/gas please refer to page 00/11

How to use capacity-sheets refer to page 00/09

Type 441, 442 Full nozzle DIN **LESER**

Capacities – Air

Capacities for air according to AD 2000-Merkblatt A2, based on set pressure plus 10 % overpressure at 0 °C and 1013 mbar. Capacities at 1 bar (14,5 psig) and below are based on 0,1 bar (1,45 psig) overpressure.

Metric Units		AD 2000-Merkblatt A2 [m ³ /h]		
DN _i		25	40	50
DN _o		40	65	80
Actual Orifice diameter d ₀ [mm]		23	37	46
Actual Orifice area A ₀ [mm ²]		416	1075	1662
LEO _{s/g} *) [inch ²]		0,462	1,195	1,847
Set pressure [bar]	Capacities [m ³ /h]			
0,1	0	0	0	
0,2	162	420	649	
0,5	263	680	1051	
1	388	1004	1552	
2	627	1622	2507	
3	854	2209	3414	
4	1071	2773	4286	
5	1289	3337	5157	
6	1507	3900	6029	
7	1725	4464	6900	
8	1943	5028	7771	
9	2161	5592	8643	
10	2379	6155	9514	
12	2814	7283	11257	
14	3250	8411	13000	
16	3686	9538	14743	
18	4121	10666	16486	
20	4557	11793	18228	
22	4993	12921	19971	
24	5429	14048	21714	
26	5864	15176	23457	
28	6300	16304	25200	
30	6736	17431	26942	
32	7171	18559	28685	
34	7607	19686	30428	
36	8043	20814	32171	
38	8478	21941	33914	
40	8914	23069	35657	

Capacities for air according to ASME Section VIII (UV), based on set pressure plus 10% overpressure at 16 °C (60°F). Capacities at 2,07 bar (30 psig) and below are based on 0,207 bar (3 psig) overpressure.

US Units		ASME Section VIII [S.C.F.M.]		
DN _i		25	40	50
DN _o		40	65	80
Actual Orifice diameter d ₀ [inch]		0,91	1,46	1,81
Actual Orifice area A ₀ [inch ²]		0,644	1,667	2,576
LEO _{s/g} *) [inch ²]		0,462	1,195	1,847
Set pressure [psig]	Capacities [S.C.F.M.]			
15	270	698	1079	
20	311	805	1244	
30	394	1019	1574	
40	484	1254	1938	
50	575	1489	2301	
60	666	1724	2664	
70	757	1959	3028	
80	848	2194	3391	
90	939	2430	3754	
100	1029	2665	4118	
120	1211	3135	4845	
140	1393	3605	5571	
160	1574	4076	6298	
180	1756	4546	7025	
200	1938	5016	7751	
220	2120	5486	8478	
240	2301	5957	9205	
260	2483	6427	9932	
280	2665	6897	10658	
300	2846	7368	11385	
320	3028	7838	12112	
340	3210	8308	12839	
360	3391	8778	13565	
380	3573	9249	14292	
400	3755	9719	15019	
420	3936	10189	15745	
440	4118	10660	16472	
460	4300	11130	17199	
480	4481	11600	17926	
500	4663	12070	18652	
550	5117	13246	20469	
580	5390	13952	21559	

*) LEO_{s/g} = LESER Effective Orifice steam/gas please refer to page 00/11
How to use capacity-sheets refer to page 00/09

Type 441, 442 Full nozzle DIN **LESER**

Capacities – Water

Capacities for water according to AD 2000-Merkblatt A2, based on set pressure plus 10 % overpressure at 20 °C (68 °F). Capacities at 1 bar (14,5 psig) and below are based on 0,1 bar (1,45 psig) overpressure.

Capacities for water according to ASME Section VIII (UV), based on set pressure plus 10 % overpressure at 21 °C (70 °F). Capacities at 2,07 bar (30 psig) and below are based on 0,207 bar (3 psig) overpressure.

Metric Units		AD 2000-Merkblatt A2 [10^3kg/h]		
	DN _i	25	40	50
	DN _o	40	65	80
	Actual Orifice diameter d _o [mm]	23	37	46
	Actual Orifice area A _o [mm ²]	416	1075	1662
	LEO _L ^{*)} [inch ²]	0,516	1,336	2,062
Set pressure [bar]	Capacities [10^3kg/h]			
0,1	4,25	11,0	17,0	
0,2	5,21	13,5	20,8	
0,5	7,37	19,1	29,5	
1	9,97	25,8	39,9	
2	14,1	36,5	56,4	
3	17,3	44,7	69,1	
4	19,9	51,6	79,8	
5	22,3	57,7	89,2	
6	24,4	63,2	97,7	
7	26,4	68,3	106	
8	28,2	73,0	113	
9	29,9	77,4	120	
10	31,5	81,6	126	
12	34,6	89,4	138	
14	37,3	96,6	149	
16	39,3	103	160	
18	42,3	110	169	
20	44,6	115	178	
22	46,8	121	187	
24	48,9	126	195	
26	50,9	132	203	
28	52,8	137	211	
30	54,6	141	219	
32	56,4	146	226	
34	58,2	151	233	
36	59,8	155	239	
38	61,5	159	246	
40	63,1	163	252	

US Units		ASME Section VIII [US-G.P.M.]		
	DN _i	25	40	50
	DN _o	40	65	80
	Actual Orifice diameter d _o [inch]	0,91	1,46	1,81
	Actual Orifice area A _o [inch ²]	0,644	1,667	2,576
	LEO _L ^{*)} [inch ²]	0,516	1,336	2,062
Set pressure [psig]	Capacities [US-G.P.M.]			
15	54,0	140	216	
20	61,1	158	244	
30	73,1	189	293	
40	84,5	219	338	
50	94,4	244	378	
60	103	268	414	
70	112	289	447	
80	119	309	478	
90	127	328	507	
100	134	346	534	
120	146	379	585	
140	158	409	632	
160	169	437	676	
180	179	464	717	
200	189	489	755	
220	198	513	792	
240	207	535	827	
260	215	557	861	
280	223	578	894	
300	231	599	925	
320	239	618	955	
340	246	637	985	
360	253	656	1013	
380	260	674	1041	
400	267	691	1068	
420	274	708	1095	
440	280	725	1120	
460	286	741	1146	
480	293	757	1170	
500	299	773	1194	
550	313	811	1253	
580	322	832	1286	

*) LEO_L = LESER Effective Orifice liquids please refer to page 00/12
How to use capacity-sheets refer to page 00/09

Type 441, 442 Full nozzle DIN **LESER**

Determination of coefficient of discharge in case of lift restriction or back pressure

- h = Lift [mm]
- d₀ = Flow diameter [mm] of selected safety valve, refer to table article numbers
- h/d₀ = Ratio of lift / flow diameter
- p_{a0} = Back pressure [bar.]
- p₀ = Set pressure [bar.]
- p_{a0}/p₀ = Ratio of back pressure / set pressure
- K_{dr} = Coefficient of discharge acc. to DIN EN ISO 4126-1
- α_w = Coefficient of discharge acc. to AD 2000-Merkblatt A2
- K_b = Back pressure correction factor acc. to API 520 topic 3.3

Diagram for evaluation of ratio of lift / flow diameter (h/d₀) in reference to the coefficient of discharge (K_{dr}/α_w)

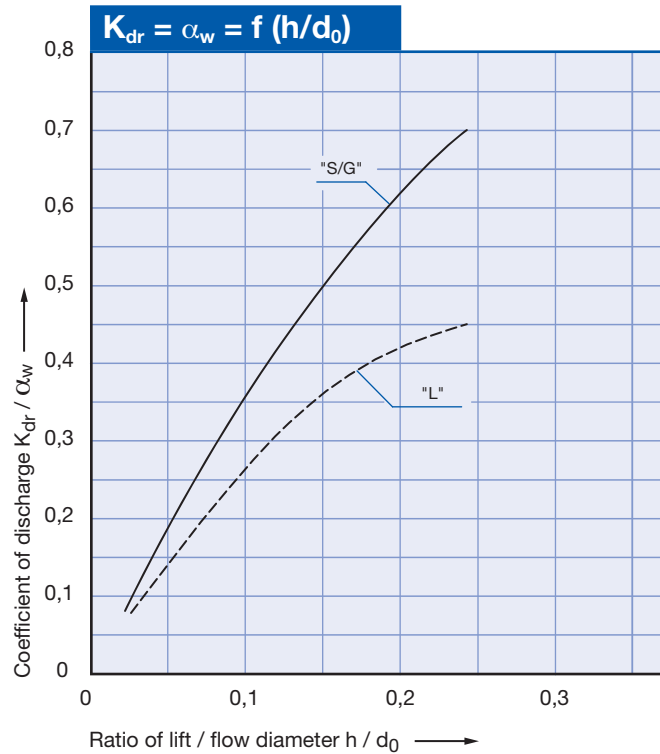
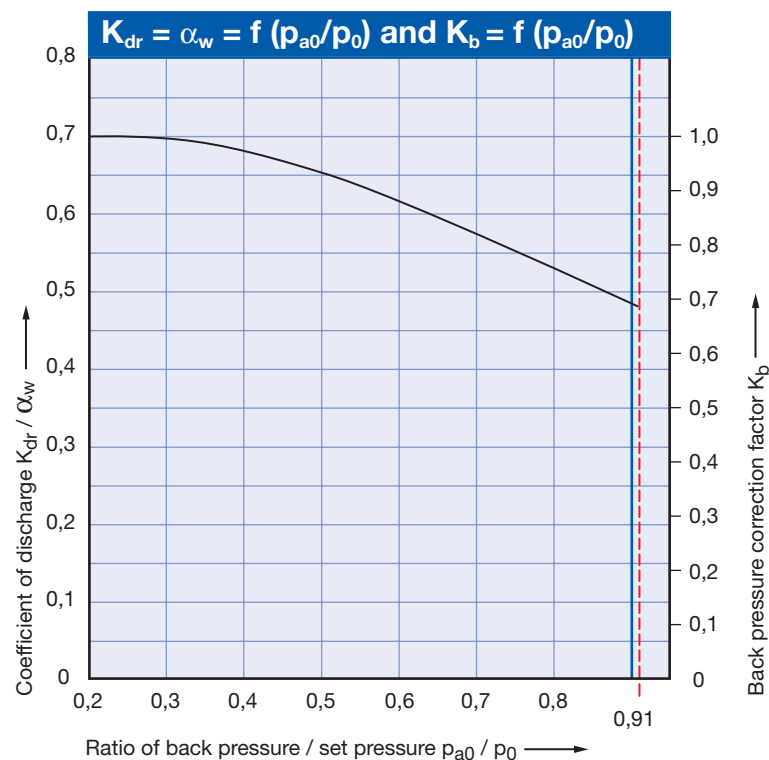

Diagram for evaluation of coefficient of discharge (K_{dr}/α_w) or K_b in reference to the ratio of back pressure / set pressure (p_{a0}/p₀)



How to use please refer to page 00/08

Type 441, 442 Full nozzle DIN **LESER**

Type 441, 442 Full nozzle DIN



Type 442 Full nozzle ANSI
Plain lever H3
Open bonnet
Conventional design



Type 441 Full nozzle ANSI
Packed lever H4
Closed bonnet
Conventional design

Type

441, 442

Full nozzle ANSI

Flanged Safety Relief Valves – spring loaded

Contents

Chapter/Page

Materials

- Conventional design 07/02
- Balanced bellows design 07/04

How to order

- Numbering system 07/06
- Article numbers 07/08

Dimensions and weights

- Metric Units 07/10
- US Units 07/11

Pressure temperature ratings

- Metric Units 07/12
- US Units 07/13

Flange drillings and facings 07/14

Order information – Spare parts 07/15

Available options 07/16

Approvals 07/17

Capacities

- Steam [Metric Units + US Units] 07/18
 - Air [Metric Units + US Units] 07/19
 - Water [Metric Units + US Units] 07/20
- Determination of coefficient
of discharge K_{dr}/α_w 07/21

Type 441, 442 Full nozzle ANSI **LESER**

Conventional design

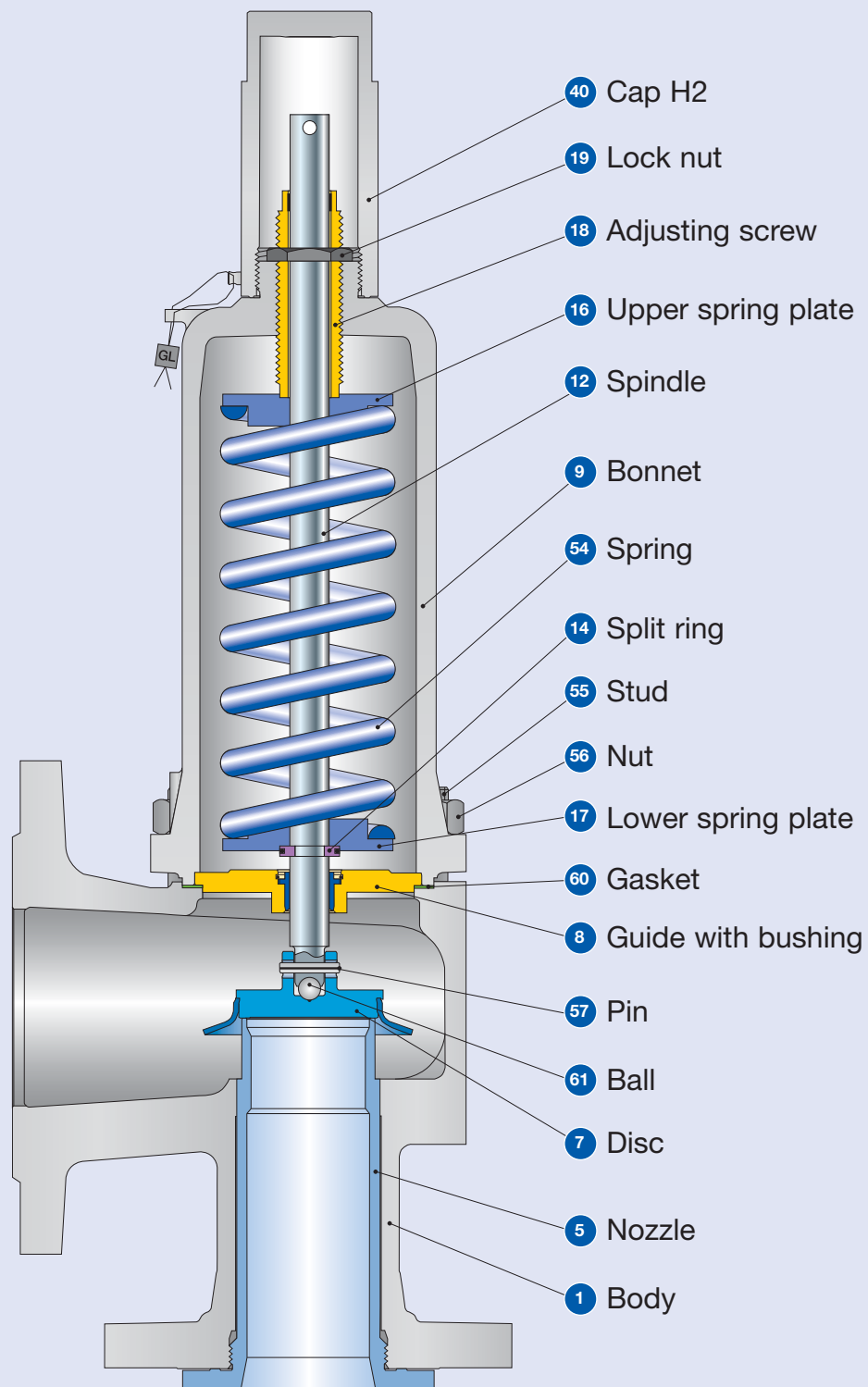

Type 441, 442 Full nozzle ANSI

Type 441, 442 Full nozzle ANSI **LESER**

Conventional design

Materials		Type 4412 / 4422 Full nozzle ANSI	Type 4414 Full nozzle ANSI
1	Body	1.0619	1.4408
		SA 216 WCB	SA 351 CF8M
5	Nozzle	1.4404	1.4404
		316L	316L
7	Disc	1.4122	1.4404
		Hardened stainless steel	316L
8	Guide with bushing	1.0501	1.4404
		Carbon steel	316L
		1.4104 tenifer	-
		Chrome steel	-
9	Bonnet	0.7040, 0.7043, 1.0619	1.4408 or 1.4571
		Ductile Gr. 60-40-18, SA 216 WCB	SA CF8M or SA 479 316Ti
12	Spindle	1.4021	1.4404
		420	316L
14	Split ring	1.4104	1.4404
		Chrome steel	316L
16 / 17	Spring plate	1.0718	1.4404
		12L13	316L
18	Adjusting screw with bushing	1.4104 PTFE	1.4404
		Chrome steel PTFE	316L PTFE
19	Lock nut	1.0718	1.4404
		Steel	316L
40	Cap H2	1.0718	1.4404
		12L13	316L
54	Spring standard	1.1200, 1.8159, 1.7102	1.4310
		Carbon steel	Stainless steel
	Spring optional	1.4310	-
55	Stud	1.1181	1.4401
		Steel	B8M
56	Nut	1.0501	1.4401
		2H	8M
57	Pin	1.4310	1.4310
		Stainless steel	Stainless steel
60	Gasket	Graphite / 1.4401	Graphite / 1.4401
		Graphite / 316	Graphite / 316
61	Ball	1.3541	1.4401
		Hardened stainless steel	316

Please notice:

- Modifications reserved by LESER.
- LESER can upgrade materials without notice.
- Every part can be replaced by other material acc. to customer specification.

Type 441, 442 Full nozzle ANSI **LESER**

Balanced bellows design

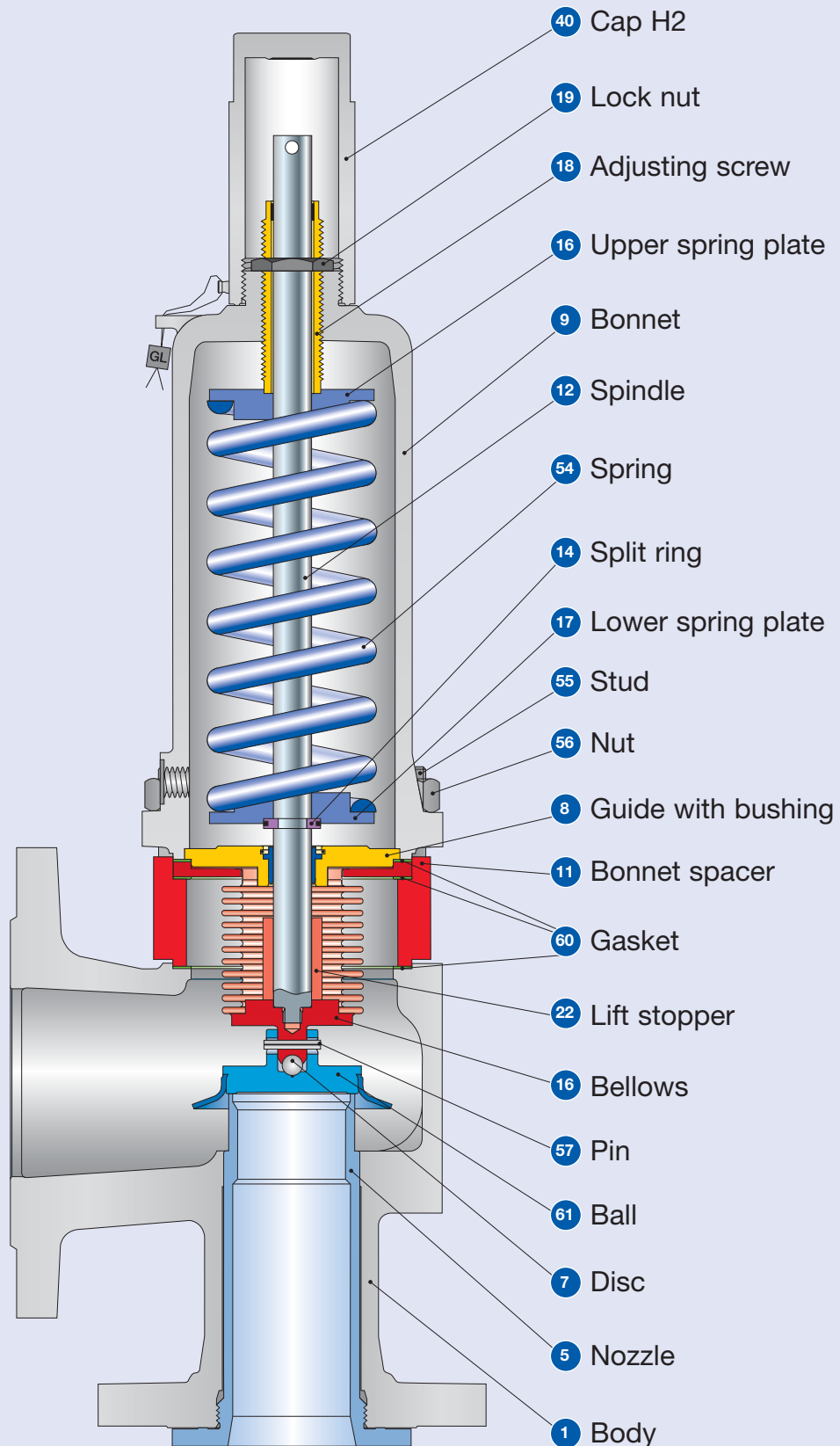

Type 441, 442 Full nozzle ANSI

Type 441, 442 Full nozzle ANSI **LESER**

Balanced bellows design

Materials		Type 4412 / 4422 Full nozzle ANSI	Type 4414 Full nozzle ANSI
1	Body	1.0619	1.4408
		SA 216 WCB	SA 351 CF8M
5	Nozzle	1.4404	1.4404
		316L	316L
7	Disc	1.4122	1.4404
		Hardened stainless steel	316L
8	Guide with bushing	1.0501/0.7040	1.4404
		Chrome or carbon steel	316L
		1.4104 tenifer	-
		Chrome steel	-
9	Bonnet	0.7040, 0.7043, 1.0619	1.4408 or 1.4571
		Ductile Gr. 60-40-18, SA 216 WCB	SA 351 CF8M or SA 479 316Ti
11	Bonnet spacer	1.0460	1.4404
		Carbon steel	316L
12	Spindle	1.4404	1.4404
		316L	316L
14	Split ring	1.4104	1.4404
		Chrome steel	316L
15	Bellows	1.4571	1.4571
		316 Ti	316 Ti
16 / 17	Spring plate	1.0718	1.4404
		Steel	316L
18	Adjusting screw with bushing	1.4104 PTFE	1.4404 PTFE
		Chrome steel PTFE	316L PTFE
19	Lock nut	1.0718	1.4404
		Steel	316L
22	Lift stopper	1.4404	1.4404
		316L	316L
40	Cap H2	1.0718	1.4404
		12L13	316L
54	Spring standard	1.1200, 1.8159, 1.7102	1.4310
		Carbon steel	Stainless steel
	Spring optional	1.4310	-
55	Stud	Stainless steel	-
		1.4401	1.4401
56	Nut	B8M	B8M
		1.4401	1.4401
57	Pin	8M	8M
		1.4310	1.4310
60	Gasket	Stainless steel	Stainless steel
		Graphite / 1.4401	Graphite / 1.4401
61	Ball	Graphite / 316	Graphite / 316
		1.3541	1.4401
		Hardened stainless steel	316

Please notice:

- Modifications reserved by LESER.
- LESER can upgrade materials without notice.
- Every part can be replaced by other material acc. to customer specification.

Type 441, 442 Full nozzle ANSI **LESER**

How to order – Numbering system

1

Article Number

1	2	3	4
441	2	128	2

1 Valve Type 441, 442 Full nozzle ANSI
 Type 441 – with closed bonnet
 Type 442 – with open bonnet

2

Code	Body material
2	1.0619 (WCB)
4	1.4408 (CF8M)

3 Valve code
 Identifies valve size and body material, refer to page 07/09.

4

Code	Lifting lever	
2	screwed cap	H2
3	plain lever	H3
4	packed lever	H4
5	plain lever with open bonnet	H3

4412.1282

Article No.

2

Set Pressure

Please state unit (in gauge)!

Please do not exceed the pressure range defined in the spring charts.

5 bar_g

Set Pressure

3

Connections

Please refer to page 07/14

H64

Connections

Type 441, 442 Full nozzle ANSI **LESER**

4

Options

Type 441, 442 Full nozzle ANSI

	Option code
• O-ring-disc	
CR "K"	J21
EPDM "D"	J22
FKM "L"	J23
FFKM "C"	J20
• Disc 1.4404 / 316L	L44
• Disc 1.4404 / 316L stellited	J25
• Detachable lifting aid	J26
• Stainless steel bellows	
- open bonnet (Type 442)	J68
- closed bonnet (Type 441)	J78
• Elastomer bellows	J79
• High temperature alloy spring	X01
• Stainless steel spring	X04
• Adaptor for lift indicator H4	J39
• Lift indicator	J93
• Test gag	
- cap H2	J70
- packed lever H4	J69
• Nozzle 316L stellited	L62
• Heating jacket	
- Couplings G 3/8	H29
G 3/4	H30
- Flanges DN 15	H31
DN 25	H32
• Drain hole G 1/4	J18
G 1/2	J19
• Free of oil and grease	J85
• Materials	
- NACE	H01

Option code applies only if not standard

J22

Options

5

Documentation

Please select requested documentation:

Inspections, tests: Option code
DIN EN 10204-3.2: TÜV-Nord Certificate for test pressure **M33**

LESER Certificate for Global Application **H03**
- Inspection certificate 3.1 acc. to DIN EN 10204
- Declaration of conformity acc. to PED 97/23/EC

Material test certificate:
DIN EN 10204-3.1

Part	Option code
Body	H01
Nozzle	L59
Bonnet	L30
Cap / lever cover	L31
Disc	L23
Studs	N07
Nuts	N08

H01

L30

Documentation

6

Code and Medium

1 **2**
2 **0**

1 Code
1. ASME Section VIII
2. CE / VdTUEV
3. ASME Section VIII + CE / VdTUEV

2 Medium
.1 Gases
.2 Liquids
.3 Steam
.0 Steam / Gases / Liquids (valid only for CE / VdTUEV)

2.0

Code and Medium

Type 441, 442 Full nozzle ANSI **LESER**

How to order – Article numbers

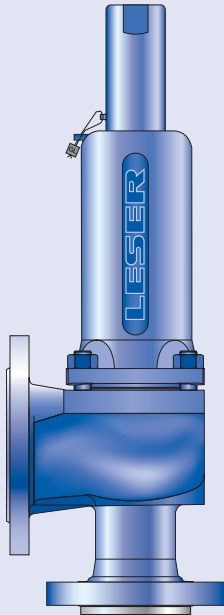

Type 441 Full nozzle
Cap H2
Closed bonnet
Conventional design

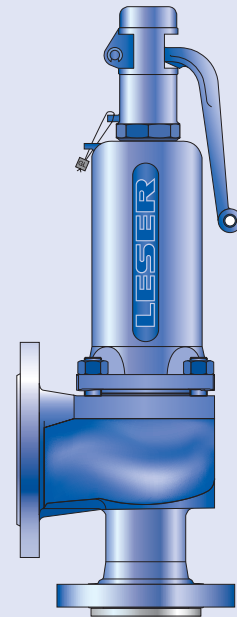

Type 441 Full nozzle
Plain lever H3
Closed bonnet
Conventional design

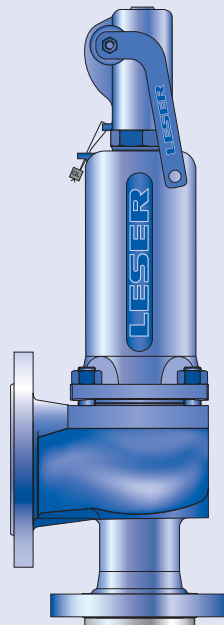

Type 441 Full nozzle
Packed lever H4
Closed bonnet
Conventional design

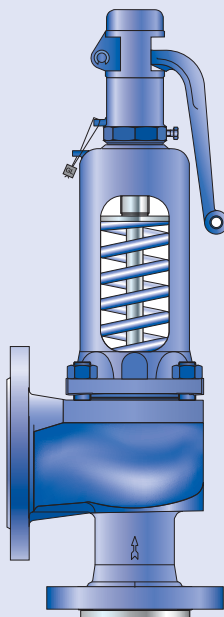

Type 442 Full nozzle
Plain lever H3
Open bonnet
Conventional design

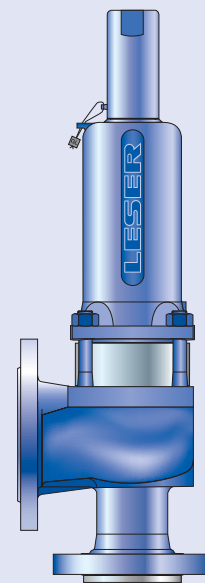

Type 441 Full nozzle
Cap H2
Closed bonnet
Balanced bellows design

Type 441, 442 Full nozzle ANSI **LESER**

How to order – Article numbers

Article numbers			1" x 2"	1 1/2" x 2"	1 1/2" x 2 1/2"	2" x 3"	3" x 4"	4" x 6"
Valve size			1" x 2"	1 1/2" x 2"	1 1/2" x 2 1/2"	2" x 3"	3" x 4"	4" x 6"
Actual Orifice diameter d ₀ [mm]			23	29	37	46	60	92
Actual Orifice area A ₀ [mm ²]			416	661	1075	1662	2827	6648
Body material: 1.0619 (WCB)								
closed	Bonnet H2	Art.-No. 4412.	1282	1292	1302	1312	1322	1332
	H3	Art.-No. 4412.	1283	1293	1303	1313	1323	1333
	H4	Art.-No. 4412.	1284	1294	1304	1314	1324	1334
open	H3	Art.-No. 4422.	1285	1295	1305	1315	1325	1335
Body material: 1.4408 (CF8M)								
closed	Bonnet H2	Art.-No. 4414.	5682	–	5702	5712	5722	5732
	H4	Art.-No. 4414.	5684	–	5704	5714	5724	5734

Type 441, 442 Full nozzle ANSI **LESER**

Dimensions and weights

Metric Units

Valve size	1" x 2"	1 1/2" x 2"	1 1/2" x 2 1/2"	2" x 3"	3" x 4"	4" x 6"
Actual Orifice diameter d_0 [mm]	23	29	37	46	60	92
Actual Orifice area A_0 [inch ²]	416	661	1075	1662	2827	6648
Weight [lbs]	10	13	16	22	33	75
with bellows	11	14	17	24	37	83
Center to face [mm]						
Inlet a	109	129,5	129,5	141	163	188
Outlet b	114	121	121	124	165	229
Height (H4) [mm]						
Standard H max.	339	455	496	556	685	844
Bellows H max.	378	497	534	602	741	902
Support brackets [mm]						
A						280
B						160
(drilled only on request)						Ø 18
D						250
E						25
Body material: 1.0619 (WCB)						
ANSI Flange Class	Inlet	CL150 or CL300				
	Outlet	CL150				
Body material: 1.4408 (CF8M)						
ANSI Flange Class	Inlet	CL150 or CL300	-	CL150 or CL300		
	Outlet	CL150	-	CL150		

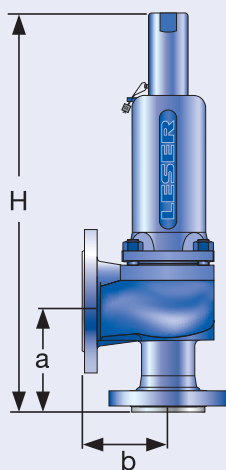

Conventional design

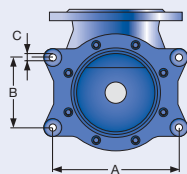
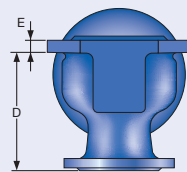

Support brackets

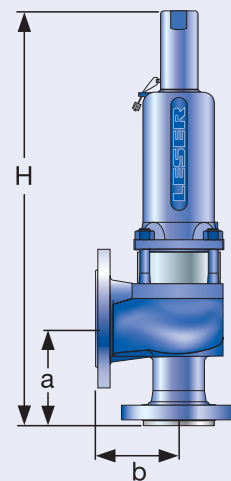

Balanced bellows design

Type 441, 442 Full nozzle ANSI **LESER**

Dimensions and weights

US Units

Valve size		1" x 2"	1 1/2" x 2"	1 1/2" x 2 1/2"	2" x 3"	3" x 4"	4" x 6"
Actual Orifice diameter d_0 [inch]		0,91	1,14	1,46	1,81	2,36	3,62
Actual Orifice area A_0 [inch ²]		0,644	1,024	1,667	2,576	4,383	10,304
Weight							
[lbs]		22	29	35	49	73	165
	with bellows	23	30	38	52	81	183
Center to face							
[inch]	Inlet a	4 1/4	5 1/8	5 1/8	5 1/2	6 3/8	7 3/8
	Outlet b	4 1/2	4 3/4	4 3/4	4 7/8	6 1/2	9
Height (H4)							
[inch]	Standard H max.	13 1/4	18 1/8	19 3/4	22 1/16	27 1/4	33 1/2
	Bellows H max.	15 1/16	19 13/16	21 1/4	23 7/8	29 7/16	35 13/16
Support brackets							
[mm]	A						11
	B						6 1/4
	C						Ø 3/4
	D						9 7/8
	E						1
Body material: 1.0619 (WCB)							
ANSI Flange Class							
	Inlet	CL150 or CL300					
	Outlet	CL150					
Body material: 1.4408 (CF8M)							
ANSI Flange Class							
	Inlet	CL150 or CL300	–	CL150 or CL300			
	Outlet	CL150	–	CL150			

Type 441, 442 Full nozzle ANSI

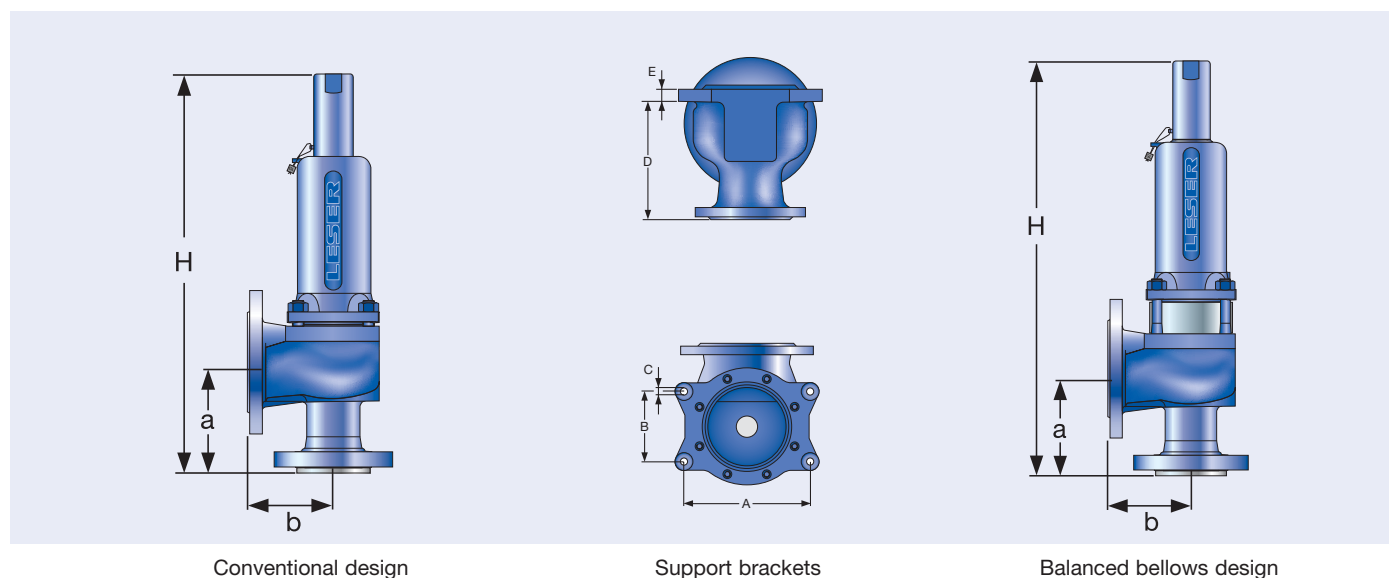

Type 441, 442 Full nozzle ANSI **LESER**

Pressure temperature ratings

Metric Units

Valve size	1" x 2"	1 1/2" x 2"	1 1/2" x 2 1/2"	2" x 3"	3" x 4"	4" x 6"
Actual Orifice diameter d_o [mm]	23	29	37	46	60	92
Actual Orifice area A_o [mm ²]	416	661	1075	1662	2827	6648

Body material: 1.0619 (WCB)

ANSI Flange Class ¹⁾	Inlet		CL150 or CL300				
	Outlet		CL150				
Minimum set pressure	p [bar _g]	S/G/L	0,1	0,1	0,1	0,1	0,1
Min. set press.²⁾ standard bellows	p [bar _g]	S/G/L	3	3	3	3	3
Minimum low press. bellows	p [bar _g]	S/G/L	0,98	1,41	1,11	1,81	1,50
Maximum set pressure	p [bar _g]	S/G/L	49	48	46	51	35
Maximum with special spring	p [bar _g]	S/G/L	51	48	46	51	40
Temperature acc. to DIN EN	min. [°C]		-85				
	max. [°C]		+450				
Temperature acc. to ASME	min. [°C]		-29				
	max. [°C]		+427				

Body material: 1.4408 (CF8M)

ANSI Flange Class ¹⁾	Inlet		CL150 or CL300	CL150 or CL300			
	Outlet		CL150	CL150			
Minimum set pressure	p [bar _g]	S/G/L	0,1	-	0,1	0,1	0,1
Min. set press.²⁾ standard bellows	p [bar _g]	S/G/L	3	-	3	3	3
Min. set press. low press. bellows	p [bar _g]	S/G/L	0,98	-	1,11	1,81	1,50
Maximum set pressure	p [bar _g]	S/G/L	42,5	-	27	25	27
Maximum with special spring	p [bar _g]	S/G/L	51	-	38	40	27
Temperature acc. to DIN EN	min. [°C]		-270	-	-270		
	max. [°C]		+400	-	+400		
Temperature acc. to ASME	min. [°C]		-268	-	-268		
	max. [°C]		+538	-	+538		

¹⁾ For flange rating class 150 the pressure temperature ratings according to ASME ANSI B 16.34 apply.

²⁾ Min. set pressure standard bellows = Max. set pressure low pressure bellows.

Type 441, 442 Full nozzle ANSI **LESER**

Pressure temperature ratings

US Units								
Valve size		1" x 2"	1 1/2" x 2"	1 1/2" x 2 1/2"	2" x 3"	3" x 4"	4" x 6"	
Actual Orifice diameter d_o [inch]		0,91	1,14	1,46	1,81	2,36	3,62	
Actual Orifice area A_o [inch ²]		0,644	1,024	1,667	2,576	4,383	10,304	
Body material: 1.0619 (WCB)								
ANSI Flange Class ¹⁾	Inlet		CL150 or CL300					
	Outlet		CL150					
Minimum set pressure	p [psig] S/G/L	1,5	1,5	1,5	1,5	1,5	1,5	
Min. set press.²⁾ standard bellows	p [psig] S/G/L	43,5	43,5	43,5	43,5	43,5	43,5	
Minimum low press. bellows	p [psig] S/G/L	14	20	16	26	22	17	
Maximum set pressure	p [psig] S/G/L	711	696	667	740	508	493	
Maximum with special spring	p [psig] S/G/L	740	696	667	740	580	493	
Temperature acc. to DIN EN	min. [°F]						-121	
	max. [°F]						+842	
Temperature acc. to ASME	min. [°F]						-20	
	max. [°F]						+800	
Body material: 1.4408 (CF8M)								
ANSI Flange Class ¹⁾	Inlet		CL150 or CL300	–	CL150 or CL300			
	Outlet		CL150	–	CL150			
Minimum set pressure	p [psig] S/G/L	1,5	–	1,5	1,5	1,5	1,5	
Min. set press.²⁾ standard bellows	p [psig] S/G/L	43,5	–	43,5	43,5	43,5	43,5	
Minimum low press. bellows	p [psig] S/G/L	14	–	16	26	22	17	
Maximum set pressure	p [psig] S/G/L	616	–	392	363	392	218	
Maximum with special spring	p [psig] S/G/L	740	–	551	580	392		
Temperature acc. to DIN EN	min. [°F]	-454	–				-454	
	max. [°F]	+752	–				+752	
Temperature acc. to ASME	min. [°F]	-450	–				-450	
	max. [°F]	+1000	–				+1000	

¹⁾ For flange rating class 150 the pressure temperature ratings according to ASME ANSI B 16.34 apply.

²⁾ Min. set pressure standard bellows = Max. set pressure low pressure bellows.

Type 441, 442 Full nozzle ANSI **LESER**

Flange drillings and facings

Flange drillings

Valve size		1" x 2"	1 1/2" x 2"	1 1/2" x 2 1/2"	2" x 3"	3" x 4"	4" x 6"	
Actual Orifice diameter d ₀ [mm]		23	29	37	46	60	92	
Actual Orifice area A ₀ [mm ²]		416	661	1075	1662	2827	6648	
Body material: 1.0619 (WCB), 1.4408 (CF8M)								
Inlet	DIN EN 1092	PN 25	Please use 441, 442 Full nozzle DIN				H47	H47
		PN 40	Please use 441, 442 Full nozzle DIN				H47	H47
	ASME B16.5	CL150	H64	H64	H64	H64	H64	H64
		CL300	*	*	*	*	*	*
Outlet	DIN EN 1092	PN 10	Please use 441, 442 Full nozzle DIN				H51	H51
		PN 16	Please use 441, 442 Full nozzle DIN				H51	H51
	ASME B16.5	CL150	*	*	*	*	*	*
		CL300	-	-	-	-	-	-

Flange facings

Indication	Standard	Nozzle	Outlet	Remark
General				
Flange undrilled	-	H38	H39	
Linde-V-Nut, Form V48	Linde Standard 420-08	-	J08	Groove: Rz 16
Linde-V-Nut, Form V48A	LWN 313.36	-	J06	Groove: Rz 4, e.g. with hydrogen
Lens seal form L (without sealing lens)	DIN 2696 LWN 313.35	L57	J12	

Acc. to DIN EN

Flange facing		DIN 2526 (old)	Inlet	Outlet	Remark
DIN EN 1092 (new)					
	see also LWN 313.40)		PN 10 – PN 40	PN 10 – PN 40	Rz-data according to DIN EN 1092 in µm
Raised face	Type B1	Type C	*	*	Facing: Rz = 12,5 – 50
		Type D			
	Type B2	Type E	-	L38	Facing: Rz = 3,2 – 12,5
Tongue face C ¹⁾		Tongue face F	L56	H92	Steel flanges only
Groove face D ¹⁾		Groove face N	L55	H91	
Male face E		Male face V13	I90	H98	
Female face F		Female face R13	I91	H99	
O-ring male face G		Male face V14	I93	J02	
O-ring female face H		Female face R14	I92	J04	

Acc. to ASME B16.5

Body material	Inlet	Outlet	Smooth finish ²⁾		Serrated finish		RTJ-groove			
			Inlet	Outlet	Inlet	Outlet	Inlet		Outlet	
			Option code	Option code	RTJ-Class	Option code	RTJ-Class	Option code		
1.0619, 1.4408	all	all	L52	L53	*	*	CL150, CL300	L58	CL150	H63

¹⁾ According to DIN EN 1092 groove depths and tongue heights increased compared to the formerly valid DIN (refer to LWN 313.40).

LESER manufactures the groove at flanged valves by milling. If a customer demands a turned surface in the soil of the groove according to DIN 2512 and/or DIN EN 1092-1 an additional option code is necessary: "S01: bottom of the groove drilled". Groove and tongue for PN160 flanges refer to DIN 2512/LWN 313.32.

²⁾ Smooth finish is not defined in the effective standards. For LESER's definition for smooth finish see page 00/07.

For signs and symbols refer to page 00/07

Note: Flange drillings and facings meet always the requirements of mentioned flange standards. Flange thickness and outer diameter may vary from flange standard.

Type 441, 442 Full nozzle ANSI **LESER**

Order information – Spare parts

Spare parts		Valve Size	1" x 2"	1 1/2" x 2"	1 1/2" x 2 1/2"	2" x 3"	3" x 4"	4" x 6"
		Actual Orifice diameter d ₀ [mm]	23	29	37	46	60	92
		Actual Orifice area A ₀ [mm ²]	416	661	1075	1662	2827	6648
Disc (Item 7): Metal to Metal seal		Material-No. / Art.-No.						
Disc	1.4122	210.9739.9000	210.9839.9000	210.9939.9000	210.8739.9000	220.1639.9000	220.1839.9000	
detachable lifting aid	1.4404	210.9749.9000	210.9849.9000	210.9949.9000	210.8749.9000	220.1649.9000	220.1849.9000	
Disc (Item 7): Soft seal		Material-No. / Art.-No.						
Disc	CR	"K"	200.5049.9051	200.5149.9051	200.5249.9051	200.5349.9051	200.5449.9051	on request
	EPDM	"D"	200.5049.9041	200.5249.9041	200.5249.9041	200.5349.9041	200.5449.9041	200.5649.9041
	FKM	"L"	200.5049.9071	200.5249.9071	200.5249.9071	200.5349.9071	200.5449.9071	200.5649.9071
	FFKM	"C"	200.5049.9091	200.5249.9091	502.0408.3591	200.5349.9091	on request	on request
Disc (Item 7.4): Soft seal		Material-No. / Art.-No.						
O-ring	CR	"K"	502.0249.3551	502.0313.3551	502.0408.3551	502.0503.3551	502.0660.5351	on request
	EPDM	"D"	502.0249.3541	502.0313.3541	502.0408.3541	502.0503.3541	502.0503.3541	502.1041.5341
	FKM	"L"	502.0249.3571	502.0313.3571	502.0408.3571	502.0503.3571	502.0503.3571	502.1041.5371
	FFKM	"C"	502.0249.3591	502.0313.3591	502.0408.3591	502.0503.3591	on request	on request
Bellows (Item 15) 1.4571		Material-No. / Art.-No.						
Standard bellows		400.0949.0000	400.1049.0000	400.1149.0000	400.1249.0000	400.1349.0000	400.0849.0000	
Conversion kit standard¹⁾		5021.1041	5021.1042	5021.1043	5021.1044	5021.1045	5021.1047	
Low pressure bellows		400.0949.0021	400.1049.0021	400.1149.0021	400.1249.0021	400.1349.0021	400.0849.0021	
Conversion kit low pressure¹⁾		please specify in writing						
Gasket – Body / bonnet (Item 60)		Material-No. / Art.-No.						
Gasket	Graphite + 1.4401	500.0607.0000	500.0807.0000	500.1007.0000	500.1207.0000	500.1607.0000	500.2107.0000	
Option code L68	Gylon (filled PTFE)	500.0605.0000	500.0805.0000	500.1005.0000	500.1205.0000	500.1605.0000	500.2105.0000	
Ball (Item 61)		Material-No. / Art.-No.						
Ball	Ball Ø [mm]	6	6	9	9	12	15	
	1.4404	510.0104.0000	510.0104.0000	510.0204.0000	510.0204.0000	510.0304.0000	510.0404.0000	
Split ring (Item 14)		Material-No. / Art.-No.						
Split ring	Spindle Ø [mm]	12	16	16	16	20	24	
	1.4404	251.0149.0000	251.0249.0000	251.0249.0000	251.0149.0000	251.0349.0000	251.0449.0000	
Pin (Item 57)		Material-No. / Art.-No.						
Pin	1.4310	480.0505.0000	480.0705.0000	480.0705.0000	480.0705.0000	480.1005.0000	480.1105.0000	

¹⁾ For pressure range see page 07/12 – 07/13.
A conversion kit contains the following components:

Item	Component	No.
8	Guide	1
11	Bonnet spacer	1
12	Spindle	1
15	Bellows	1
55	Stud	4, 8 depends on valve size
60	Gasket	2, 3 depends on valve size
	Installation instruction LWN 037.05	1

Refer to page 07/04

Type 441, 442 Full nozzle ANSI **LESER**

Available Options

For further information refer to
"Accessories and Options", page 99/01

Type 441, 442 Full nozzle ANSI

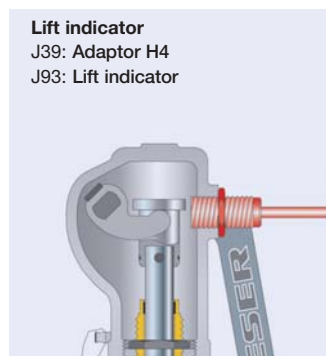
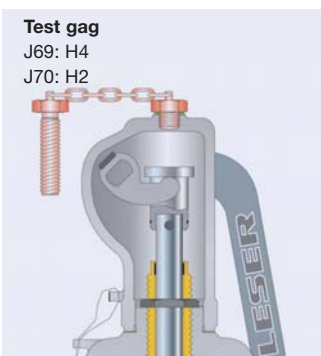
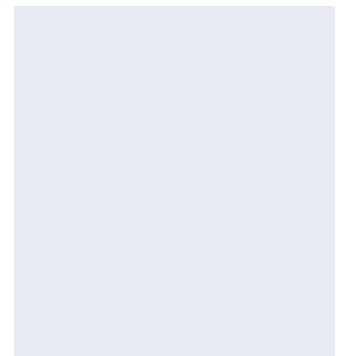
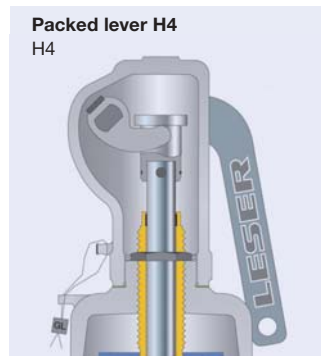
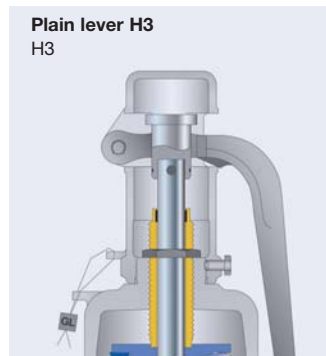
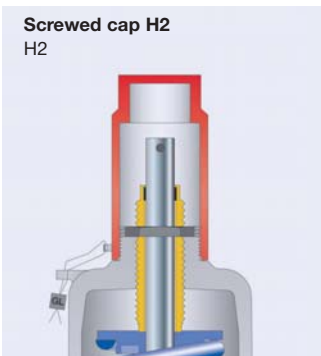
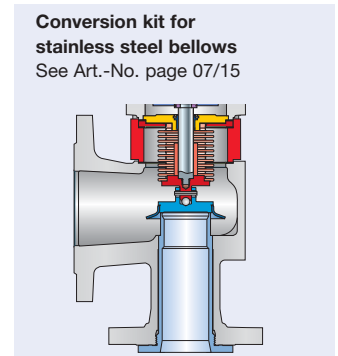
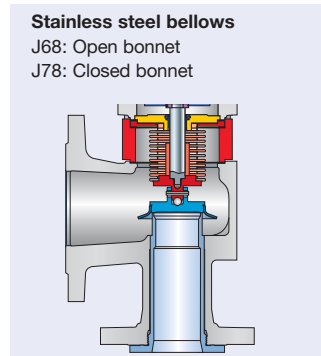
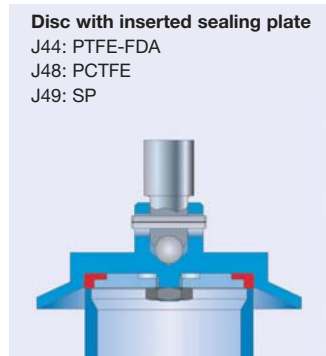
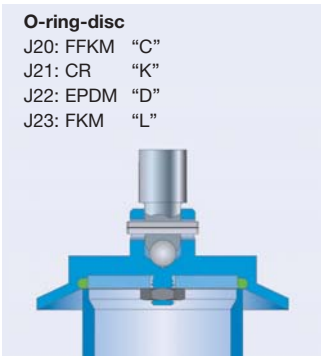
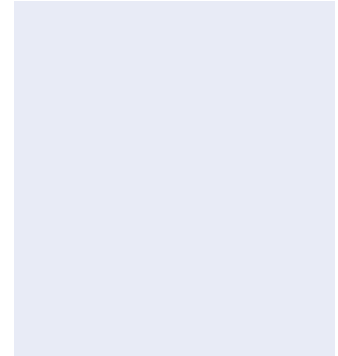
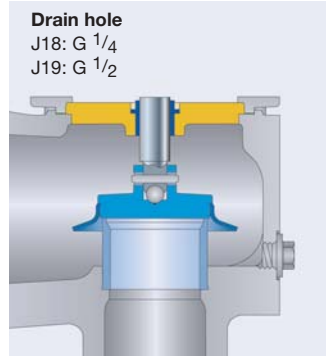
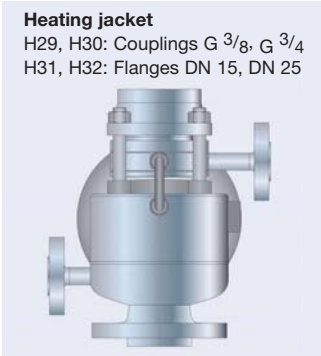

Type 441, 442 Full nozzle ANSI **LESER**

Approvals

Approvals		
	Valve size	1" x 2" up to 4" x 6"
	Actual Orifice diameter d_0 [mm]	23 – 92
	Actual Orifice area A_0 [mm ²]	416 – 6648
Europe		Coefficient of discharge K_{dr}
DIN EN ISO 4126-1	Approval No.	072020111Z0008/0/08-2
	S/G	0,7
	L	0,45
Germany		Coefficient of discharge α_w
AD 2000-Merkblatt A2	Approval No.	TÜV SV 576
	S/G	0,7
	L	0,45
United States		Coefficient of discharge K
ASME Sec. VIII	Approval No.	M37044
	S/G	0,699
	Approval No.	M37055
	L	0,521
Canada		Coefficient of discharge K
Canada: CRN	Approval No.	OG1182.9C
	S/G	0,699
	L	0,521
China		Coefficient of discharge α_w
CSBQTS	Approval No.	
	S/G	0,7
	L	0,45
Russia		Coefficient of discharge α_w
		<input type="text" value="on request"/>
Belarus		Coefficient of discharge α_w
PROMATOMNADZOR	Approval No.	15-171-2006
	S/G	0,7
	L	0,45
Classification societies		<input type="text" value="on request"/>

Type 441, 442 Full nozzle ANSI **LESER**

Capacities – Steam

Capacities for saturated steam according to AD 2000-Merkblatt A2, based on set pressure plus 10 % overpressure.

Capacities at 1 bar (14,5 psig) and below are based on 0,1 bar (1,45 psig) overpressure.

Metric Units	AD 2000-Merkblatt A2 [kg/h]					
Valve size	1" x 2"	1½" x 2"	1½" x 2½"	2" x 3"	3" x 4"	4" x 6"
Act. Orifice dia. d ₀ [mm]	23	29	37	46	60	92
Act. Orifice area A ₀ [mm ²]	416	661	1075	1662	2827	6648
LEO _{s/g} ^{*)} [inch ²]	0,462	0,734	1,195	1,847	3,142	7,387
Set pressure [bar]	Capacities [kg/h]					
0,1	0	0	0	0	0	0
0,2	140	223	363	561	954	2243
0,5	224	356	579	895	1523	3580
1	326	518	843	1302	2215	5209
2	519	825	1343	2075	3531	8302
3	699	1111	1808	2794	4754	11178
4	871	1385	2254	3485	5928	13938
5	1043	1658	2699	4172	7097	16687
6	1214	1930	3142	4856	8262	19426
7	1381	2196	3574	5525	9399	22098
8	1551	2466	4014	6205	10556	24818
9	1721	2736	4454	6884	11712	27535
10	1891	3006	4893	7562	12866	30250
12	2230	3545	5770	8919	15174	35675
14	2562	4073	6629	10247	17433	40987
16	2900	4610	7505	11600	19735	46400
18	3239	5149	8382	12955	22041	51820
20	3578	5688	9260	14312	24350	57249
22	3907	6212	10111	15629	26590	62515
24	4247	6752	10991	16988	28903	67953
26	4588	7294	11873	18351	31222	73405
28	4930	7837	12757	19718	33547	78873
30	5272	8382	13644	21089	35880	84358
32	5616	8929	14534	22465	38220	89860
34	5945	9451	15384	23779	40455	95115
36	6290	10000	16278	25160	42806	
38	6637	10551	17175	26547	45165	
40	6985	11104	18076	27939		
42	7334	11660	18980	29337		
44	7685	12218	19888	30740		
46	8037	12778	20800	32150		
48	8391	13341		33566		
51	8747			34988		
	8900			35600		

Capacities for saturated steam according to ASME Section VIII (UV), based on set pressure plus 10% overpressure.

Capacities at 2,07 bar (30 psig) and below are based on 0,207 bar (3 psig) overpressure.

US Units	ASME Section VIII [lb/h]					
Valve size	1" x 2"	1½" x 2"	1½" x 2½"	2" x 3"	3" x 4"	4" x 6"
Act. Orifice dia. d ₀ [inch]	0,91	1,14	1,46	1,81	2,36	3,62
Act. Orifice area A ₀ [inch ²]	0,644	1,024	1,667	2,576	4,383	10,304
LEO _{s/g} ^{*)} [inch ²]	0,462	0,734	1,195	1,847	3,142	7,387
Set pressure [psig]	Capacities [lb/h]					
15	757	1204	1959	3028	5152	12113
20	873	1388	2259	3492	5941	13968
30	1105	1756	2859	4419	7519	17677
40	1360	2162	3519	5439	9254	21757
50	1615	2567	4179	6459	10989	25837
60	1870	2973	4839	7479	12725	29917
70	2125	3378	5499	8499	14460	33997
80	2380	3783	6159	9519	16196	38078
90	2635	4189	6819	10539	17931	42158
100	2890	4594	7479	11559	19666	46238
120	3400	5405	8799	13600	23137	54398
140	3910	6216	10118	15640	26608	62558
160	4420	7027	11438	17680	30079	70719
180	4930	7838	12758	19720	33550	78879
200	5440	8648	14078	21760	37020	87039
220	5950	9459	15398	23800	40491	95200
240	6460	10270	16718	25840	43962	103360
260	6970	11081	18038	27880	47433	111520
280	7480	11892	19358	29920	50904	119680
300	7990	12703	20677	31960	54375	127841
320	8500	13513	21997	34000	57845	136001
340	9010	14324	23317	36040	61316	144161
360	9520	15135	24637	38080	64787	152321
380	10030	15946	25957	40120	68258	160482
400	10540	16757	27277	42161	71729	168642
420	11050	17567	28597	44201	75199	176802
440	11560	18378	29917	46241	78670	184963
460	12070	19189	31236	48281	82141	193123
480	12580	20000	32556	50321	85612	201283
500	13090	20811	33876	52361	89083	209443
550	14365	22838	37176	57461	97760	
600	15640	24865	40476	62561		
650	16915	26892	43775	67661		
700	18190	28919		72762		
740	19210			76842		

^{*)} LEO_{s/g} = LESER Effective Orifice steam/gas please refer to page 00/11
How to use capacity-sheets refer to page 00/09

Type 441, 442 Full nozzle ANSI **LESER**

Capacities – Air

Capacities for air according to AD 2000-Merkblatt A2, based on set pressure plus 10 % overpressure at 0 °C and 1013 mbar. Capacities at 1 bar (14,5 psig) and below are based on 0,1 bar (1,45 psig) overpressure.

Metric Units	AD 2000-Merkblatt A2 [m _n ³ /h]					
Valve size	1" x 2"	1½" x 2"	1½" x 2½"	2" x 3"	3" x 4"	4" x 6"
Act. Orifice dia. d ₀ [mm]	23	29	37	46	60	92
Act. Orifice area A ₀ [mm ²]	416	661	1075	1662	2827	6648
LEO _{S/G} *) [inch ²]	0,462	0,734	1,195	1,847	3,142	7,387
Set pressure [bar]	Capacities [m _n ³ /h]					
0,1	0	0	0	0	0	0
0,2	162	258	420	649	1105	2597
0,5	263	418	680	1051	1789	4206
1	388	617	1004	1552	2641	6209
2	627	996	1622	2507	4265	10026
3	854	1357	2209	3414	5809	13657
4	1071	1703	2773	4286	7291	17143
5	1289	2050	3337	5157	8774	20629
6	1507	2396	3900	6029	10257	24114
7	1725	2742	4464	6900	11739	27600
8	1943	3089	5028	7771	13222	31086
9	2161	3435	5592	8643	14704	34571
10	2379	3781	6155	9514	16187	38057
12	2814	4474	7283	11257	19152	45028
14	3250	5167	8411	13000	22117	52000
16	3686	5859	9538	14743	25082	58971
18	4121	6552	10666	16486	28047	65942
20	4557	7245	11793	18228	31012	72913
22	4993	7938	12921	19971	33977	79885
24	5429	8630	14048	21714	36943	86856
26	5864	9323	15176	23457	39908	93827
28	6300	10016	16304	25200	42873	100799
30	6736	10708	17431	26942	45838	107770
32	7171	11401	18559	28685	48803	114741
34	7607	12094	19686	30428	51768	121713
36	8043	12786	20814	32171	54733	
38	8478	13479	21941	33914	57698	
40	8914	14172	23069	35657	60663	
42	9350	14864	24197	37399		
44	9786	15557	25324	39142		
46	10221	16250	26452	40885		
48	10657	16942		42628		
50	11093			44371		
51	11311			45242		

*) LEO_{S/G} = LESER Effective Orifice steam/gas please refer to page 00/11
How to use capacity-sheets refer to page 00/09

Capacities for air according to ASME Section VIII (UV), based on set pressure plus 10% overpressure at 16 °C (60 °F). Capacities at 2,07 bar (30 psig) and below are based on 0,207 bar (3 psig) overpressure.

US Units	ASME Section VIII [S.C.F.M.]					
Valve size	1" x 2"	1½" x 2"	1½" x 2½"	2" x 3"	3" x 4"	4" x 6"
Act. Orifice dia. d ₀ [inch]	0,91	1,14	1,46	1,81	2,36	3,62
Act. Orifice area A ₀ [inch ²]	0,644	1,024	1,667	2,576	4,383	10,304
LEO _{S/G} *) [inch ²]	0,462	0,734	1,195	1,847	3,142	7,387
Set pressure [psig]	Capacities [S.C.F.M.]					
15	270	429	698	1079	1835	4315
20	311	494	805	1244	2116	4976
30	394	626	1019	1574	2679	6297
40	484	770	1254	1938	3297	7750
50	575	915	1489	2301	3915	9204
60	666	1059	1724	2664	4533	10657
70	757	1204	1959	3028	5152	12111
80	848	1348	2194	3391	5770	13564
90	939	1492	2430	3754	6388	15018
100	1029	1637	2665	4118	7006	16471
120	1211	1926	3135	4845	8243	19378
140	1393	2215	3605	5571	9479	22285
160	1574	2504	4076	6298	10716	25192
180	1756	2792	4546	7025	11952	28099
200	1938	3081	5016	7751	13189	31006
220	2120	3370	5486	8478	14425	33913
240	2301	3659	5957	9205	15662	36820
260	2483	3948	6427	9932	16898	39727
280	2665	4237	6897	10658	18135	42633
300	2846	4526	7368	11385	19371	45540
320	3028	4815	7838	12112	20608	48447
340	3210	5104	8308	12839	21844	51354
360	3391	5392	8778	13565	23081	54261
380	3573	5681	9249	14292	24317	57168
400	3755	5970	9719	15019	25554	60075
420	3936	6259	10189	15745	26791	62982
440	4118	6548	10660	16472	28027	65889
460	4300	6837	11130	17199	29264	68796
480	4481	7126	11600	17926	30500	71703
500	4663	7415	12070	18652	31737	74610
550	5117	8137	13246	20469	34828	
600	5572	8859	14422	22286		
650	6026	9581	15598	24103		
700	6480	10303		25920		
740	6843			27373		

Type 441, 442 Full nozzle ANSI

Type 441, 442 Full nozzle ANSI **LESER**

Capacities – Water

Capacities for water according to AD 2000-Merkblatt A2, based on set pressure plus 10 % overpressure at 20 °C (68 °F). Capacities at 1 bar (14,5 psig) and below are based on 0,1 bar (1,45 psig) overpressure.

Capacities for water according to ASME Section VIII (UV), based on set pressure plus 10 % overpressure at 21 °C (70 °F). Capacities at 2,07 bar (30 psig) and below are based on 0,207 bar (3 psig) overpressure.

Metric Units		AD 2000-Merkblatt A2 [10 ³ kg/h]					
Valve size	1"x 2"	1 1/2" x 2"	1 1/2" x 2 1/2"	2" x 3"	3" x 4"	4" x 6"	
Act. Orifice dia. d ₀ [mm]	23	29	37	46	60	92	
Act. Orifice area A ₀ [mm ²]	416	661	1075	1662	2827	6648	
LEO _L ^{*)} [inch ²]	0,516	0,821	1,336	2,065	3,513	8,259	
Set pressure [bar]	Capacities [10 ³ kg/h]						
0,1	4,25	6,76	11,0	17,0	28,9	68,0	
0,2	5,21	8,28	13,5	20,8	35,4	83,3	
0,5	7,37	11,7	19,1	29,5	50,1	118	
1	10,0	15,9	25,8	39,9	67,9	160	
2	14,1	22,4	36,5	56,4	96,0	226	
3	17,3	27,5	44,7	69,1	118	276	
4	19,9	31,7	51,6	79,8	136	319	
5	22,3	35,5	57,7	89,2	152	357	
6	24,4	38,8	63,2	97,7	166	391	
7	26,4	42,0	68,3	106	180	422	
8	28,2	44,8	73,0	113	192	451	
9	29,9	47,6	77,4	120	204	479	
10	31,5	50,1	81,6	126	215	505	
12	34,6	54,9	89,4	138	235	553	
14	37,3	59,3	96,6	149	254	597	
16	39,9	63,4	103	160	271	638	
18	42,3	67,3	110	169	288	677	
20	44,6	70,9	115	178	304	714	
22	46,8	74,4	121	187	318	748	
24	48,9	77,7	126	195	333	782	
26	50,9	80,9	132	203	346	814	
28	52,8	83,9	137	211	359	844	
30	54,6	86,8	141	219	372	874	
32	56,4	89,7	146	226	384	903	
34	58,2	92,5	151	233	396	931	
36	59,8	95,1	155	239	407		
38	61,5	97,7	159	246	418		
40	63,1	100	163	252	429		
42	64,6	103	167	259			
44	66,2	105	171	265			
46	67,6	108	175	271			
48	69,1	110		276			
50	70,5			282			
51	71,2			285			

US Units		ASME Section VIII [US-G.P.M.]					
Valve size	1"x 2"	1 1/2" x 2"	1 1/2" x 2 1/2"	2" x 3"	3" x 4"	4" x 6"	
Act. Orifice dia. d ₀ [inch]	0,91	1,14	1,46	1,81	2,36	3,62	
Act. Orifice area A ₀ [inch ²]	0,644	1,024	1,667	2,576	4,383	10,304	
LEO _L ^{*)} [inch ²]	0,516	0,821	1,336	2,065	3,513	8,259	
Set pressure [psig]	Capacities [US-G.P.M.]						
15	54,0	85,9	140	216	368	864	
20	61,1	97,1	158	244	416	977	
30	73,1	116	189	293	498	1170	
40	84,5	134	219	338	575	1351	
50	94,4	150	244	378	643	1511	
60	103	164	268	414	704	1655	
70	112	178	289	447	760	1787	
80	119	190	309	478	813	1911	
90	127	201	328	507	862	2027	
100	134	212	346	534	909	2136	
120	146	233	379	585	996	2340	
140	158	251	409	632	1075	2528	
160	169	269	437	676	1150	2702	
180	179	285	464	717	1219	2866	
200	189	300	489	755	1285	3021	
220	198	315	513	792	1348	3169	
240	207	329	535	827	1408	3310	
260	215	342	557	861	1465	3445	
280	223	355	578	894	1521	3575	
300	231	368	599	925	1574	3700	
320	239	380	618	955	1626	3822	
340	246	391	637	985	1676	3939	
360	253	403	656	1013	1724	4054	
380	260	414	674	1041	1772	4165	
400	267	425	691	1068	1818	4273	
420	274	435	708	1095	1862	4378	
440	280	445	725	1120	1906	4481	
460	286	455	741	1146	1949	4582	
480	293	465	757	1170	1991	4681	
500	299	475	773	1194	2032	4777	
550	313	498	811	1253	2131		
600	327	520	847	1308			
650	340	541	881	1362			
700	353	562		1413			
740	363			1453			

^{*)} LEO_L = LESER Effective Orifice liquids please refer to page 00/12
How to use capacity-sheets refer to page 00/09

Type 441, 442 Full nozzle ANSI **LESER**

Determination of coefficient of discharge in case of lift restriction or back pressure

- h = Lift [mm]
- d₀ = Flow diameter [mm] of selected safety valve, refer to table article numbers
- h/d₀ = Ratio of lift / flow diameter
- p_{a0} = Back pressure [bar.]
- p₀ = Set pressure [bar.]
- p_{a0}/p₀ = Ratio of back pressure / set pressure
- K_{dr} = Coefficient of discharge acc. to DIN EN ISO 4126-1
- α_w = Coefficient of discharge acc. to AD 2000-Merkblatt A2
- K_b = Back pressure correction factor acc. to API 520 topic 3.3

Diagram for evaluation of ratio of lift / flow diameter (h/d₀) in reference to the coefficient of discharge (K_{dr}/α_w)

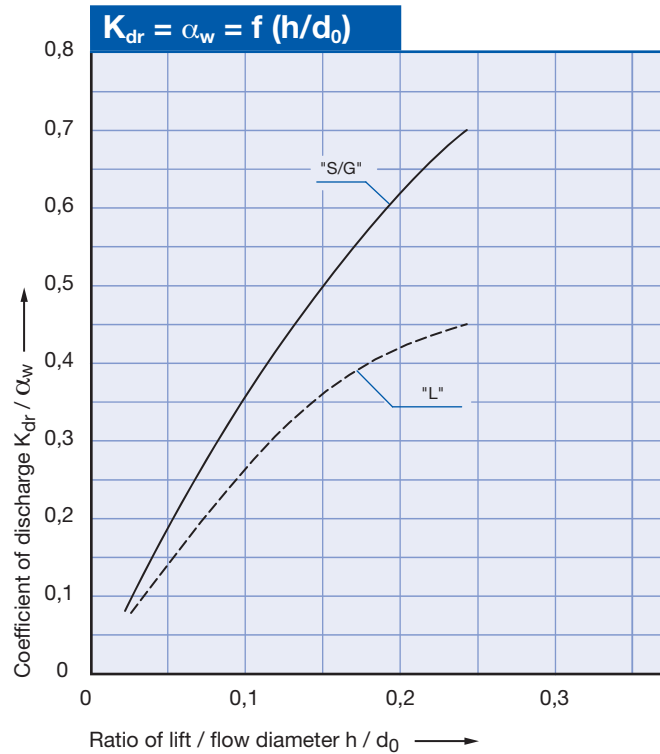
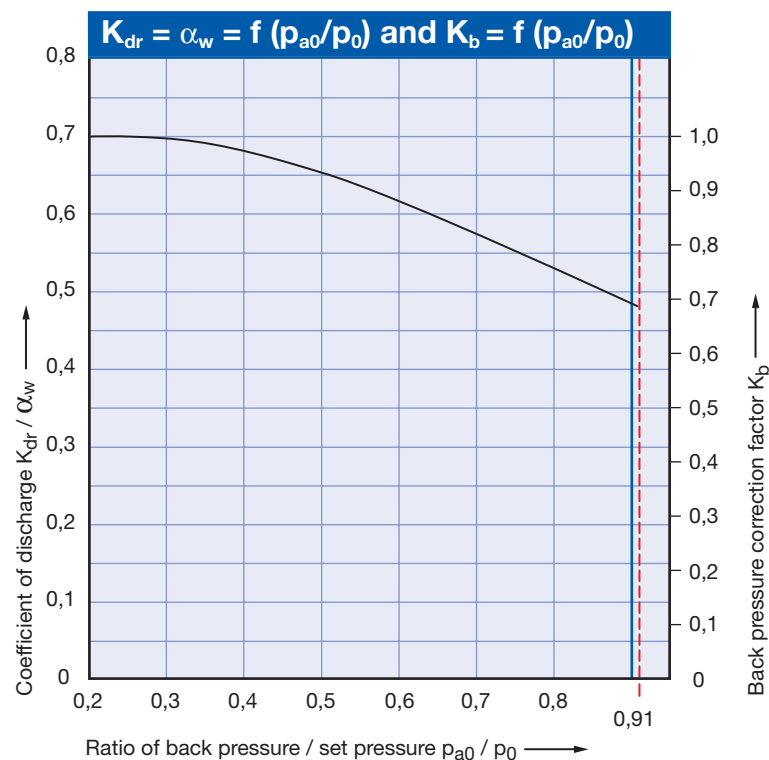

Diagram for evaluation of coefficient of discharge (K_{dr}/α_w) or K_b in reference to the ratio of back pressure / set pressure (p_{a0}/p₀)



How to use please refer to page 00/08

Type 441, 442 Full nozzle ANSI **LESER**

Type 441, 442 Full nozzle ANSI

Type 455, 456

Flanged Safety Relief Valves – spring loaded



Type 456
Packed lever H4
Closed bonnet
Conventional design

Contents Chapter/Page

Materials	
• Conventional design	08/02
• Balanced bellows design	08/04
How to order	
• Numbering system	08/06
• Article numbers	08/08
Dimensions and weights	
• Metric Units	08/10
• US Units	08/11
Pressure temperature ratings	
• Metric Units	08/12
• US Units	08/13
Flange drillings and facings	08/14
Order information – Spare parts	08/15
Available options	08/16
Approvals	08/17
Capacities	
• Steam [Metric Units + US Units]	08/18
• Air [Metric Units + US Units]	08/19
• Water [Metric Units + US Units]	08/20
Determination of coefficient of discharge K_{dr}/α_w	08/21

Conventional design

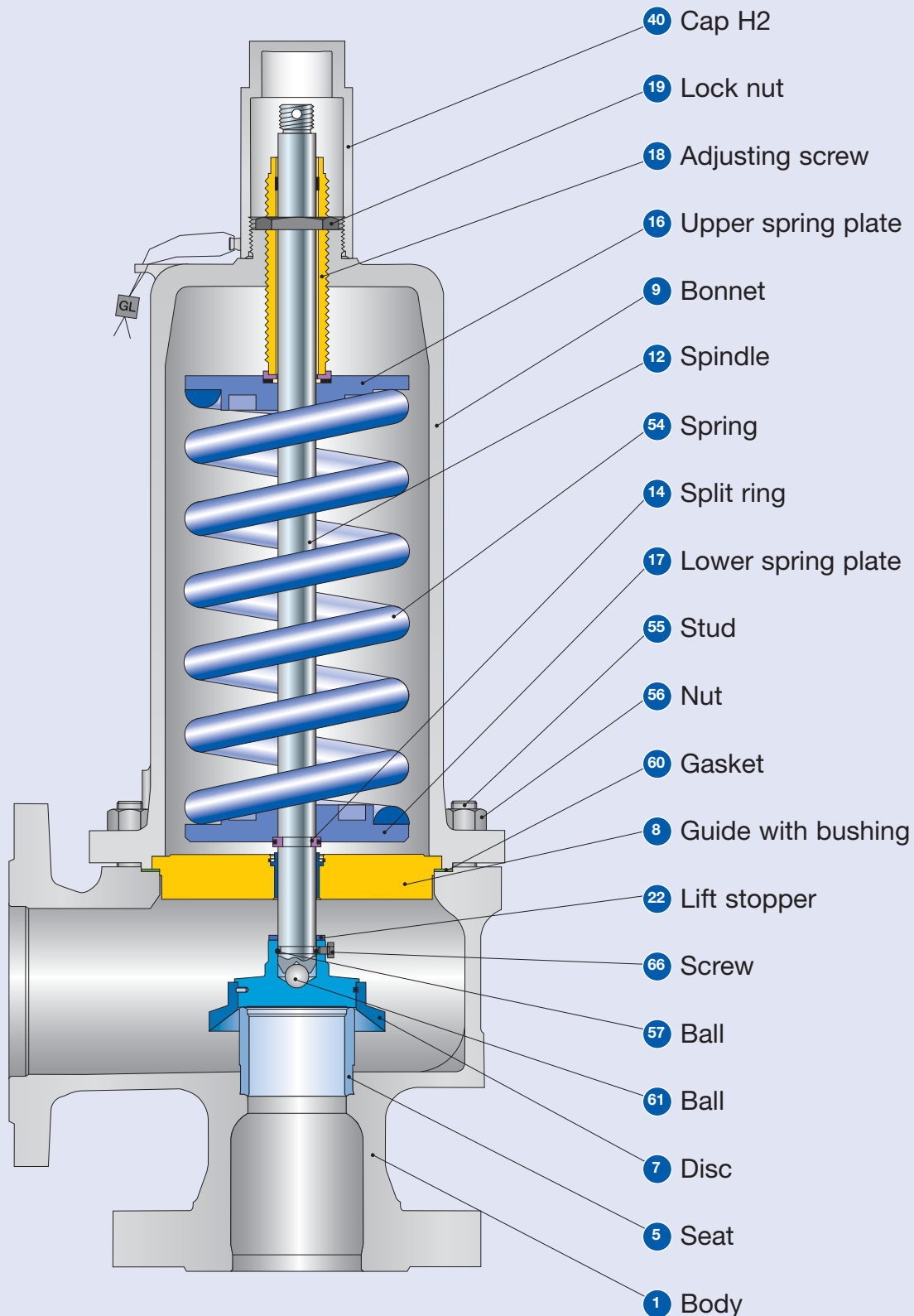

Conventional design

Materials		Type 4552 / 4562	Type 4564
1	Body	1.0619 SA 216 WCB	1.4581 SA 351 CF10M
5	Seat	1.4404 316L	1.4404 316L
7	Disc	1.4122 Hardened stainless steel	1.4404 316L
8	Guide with bushing	1.0501, 0.7040	1.4404
		Chrome or carbon steel	316L
		1.4104 tenifer Chrome steel	- -
9	Bonnet	0.7043 (Open bonnet 0.7040), 1.0619 Ductile Gr. 60-40-18, SA 216 WCB	1.4408, 1.4404, 1.4571 SA 351 CF8M, SA 479 316L, 316Ti
12	Spindle	1.4404 316L	1.4404 316L
14	Split ring	1.4104 Chrome steel	1.4404 316L
16 / 17	Spring plate	1.0718 Steel	1.4404 316L
18	Adjusting screw with bushing	1.4104 PTFE Chrome steel PTFE	1.4404 PTFE 316L PTFE
19	Lock nut	1.0718 Steel	1.4404 316L
22	Lift stopper	1.4404 316L	1.4404 316L
40	Cap H2	1.0718 12L13	1.4404 316L
54	Spring standard	1.1200, 1.8159, 1.7102 Carbon steel	1.4310 Stainless steel
	Spring optional	1.4310 Stainless steel	- -
55	Stud	1.4401 B8M	1.4401 B8M
56	Nut	1.4401 8M	1.4401 8M
57	Ball	1.4401 316	1.4401 316
60	Gasket	Graphite / 1.4401 Graphite / 316	Graphite / 1.4401 Graphite / 316
61	Ball	1.3541 Hardened stainless steel	1.4401 316
66	Screw	1.4401 B8M	1.4401 B8M

Please notice:

- Modifications reserved by LESER.
- LESER can upgrade materials without notice.
- Every part can be replaced by other material acc. to customer specification.

Balanced bellows design

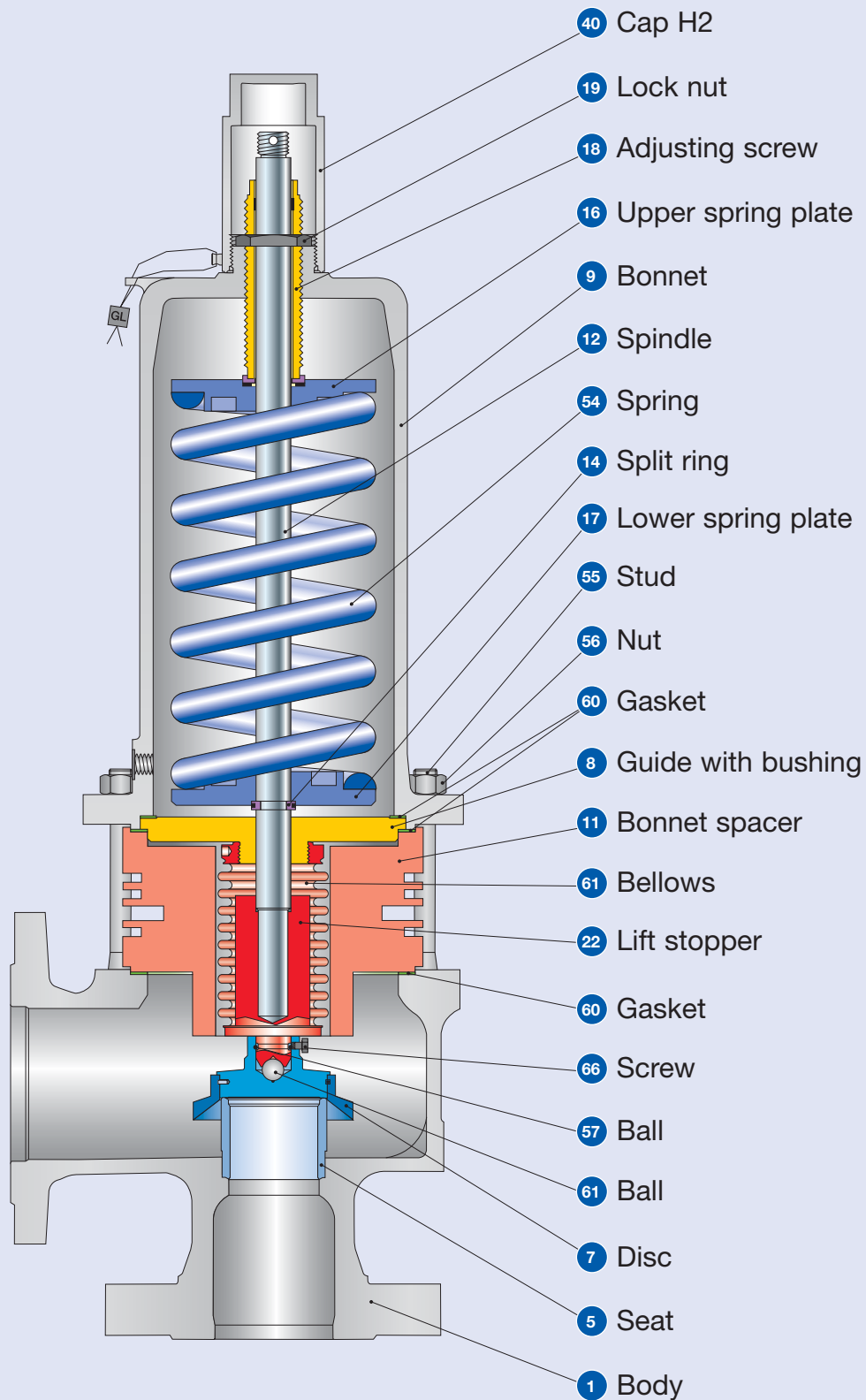

Balanced bellows design

Materials			
Item	Component	Type 4552 / 4562	Type 4564
1	Body	1.0619	1.4581
		SA 216 WCB	SA 351 CF10M
5	Seat	1.4404	1.4404
		316L	316L
7	Disc	1.4122	1.4404
		Hardened stainless steel	316L
8	Guide with bushing	1.0501, 0.7040	1.4404
		Chrome or carbon steel	316L
		1.4104 tenifer	-
		Chrome steel	-
9	Bonnet	0.7043 or 1.0619	1.4408, 1.4404, 1.4571
		Ductile Gr. 60-40-18 or SA 216 WCB	SA 351 CF8M, SA 479 316L, 316Ti
11	Bonnet spacer	1.0460	1.4404
		Carbon steel	316L
12	Spindle	1.4404	1.4404
		316L	316L
14	Split ring	1.4104	1.4404
		Chrome steel	316L
15	Bellows	1.4571	1.4571
		316Ti	316Ti
16 / 17	Spring plate	1.0718	1.4404
		Steel	316L
18	Adjusting screw with bushing	1.4104 PTFE	1.4404 PTFE
		Chrome steel PTFE	316L PTFE
19	Lock nut	1.0718	1.4404
		Steel	316L
22	Lift stopper	1.4404	1.4404
		316L	316L
40	Cap H2	1.0718	1.4404
		12L13	316L
54	Spring standard	1.1200, 1.8159, 1.7102	1.4310
		Carbon steel	Stainless steel
		1.4310	-
	Spring optional	Stainless steel	-
55	Stud	1.7709	1.4401
		B16	B8M
56	Nut	1.7258	1.4401
		7M	8M
57	Ball	1.4401	1.4401
		316	316
60	Gasket	Graphite / 1.4401	Graphite / 1.4401
		Graphite / 316	Graphite / 316
61	Ball	1.3541	1.4401
		Hardened stainless steel	316
66	Screw	1.4401	1.4401
		B8M	B8M

Please notice:

- Modifications reserved by LESER.
- LESER can upgrade materials without notice.
- Every part can be replaced by other material acc. to customer specification.

How to order – Numbering system

1

Article Number

1	2	3	4
456	2	601	2

1 Valve Type 455, 456
 Type 456 – with closed bonnet
 Type 455 – with open bonnet

2 Material code

Code	Body material
2	1.0619 (WCB)
4	1.4581 (CF10M)

3 Valve code
 Identifies valve size and body material, refer to page 08/09.

4

Code	Lifting lever	
2	screwed cap	H2
3	plain lever	H3
4	packed lever	H4
5	plain lever with open bonnet	H3

4562.6012

Article No.

2

Set Pressure

Please state unit (in gauge)!

Please do not exceed the pressure range defined in the spring charts.

5 bar_g

Set Pressure

3

Connections

Please refer to page 08/14

H47

Connections

4

Options

Type 455, 456

- O-ring-disc

	Option code
CR	"K" J21
EPDM	"D" J22
FKM	"L" J23
FFKM	"C" J20

- Disc 1.4404 / 316L **L44**
- Disc 1.4404 / 316L stellited **J25**
- Stainless steel bellows
 - open bonnet (Type 455) **J68**
 - closed bonnet (Type 456) **J78**
- High temperature alloy spring **X01**
- Stainless steel spring **X04**
- Adaptor for lift indicator H4 **J39**
- Lift indicator **J93**
- Test gag
 - cap H2 **J70**
 - packed lever H4 **J69**
- Seat 1.4404 / 316L stellited **L61**
- Heating jacket
 - Couplings G 3/8 **H29**
 - G 3/4 **H30**
 - Flanges DN 15 **H31**
 - DN 25 **H32**
 - Spacer **H33**
- Drain hole G 1/4 **J18**
- G 1/2 **J19**
- Free of oil and grease **J85**
- Materials
 - NACE **H01**

Option code applies only if not standard

J22

Options

5

Documentation

Please select requested documentation:

Inspections, tests: Option code
 DIN EN 10204-3.2: TÜV-Nord
 Certificate for test pressure **M33**

LESER Certificate for Global Application **H03**
 - Inspection certificate 3.1 acc. to DIN EN 10204
 - Declaration of conformity acc. to PED 97/23/EC

Material test certificate:
 DIN EN 10204-3.1

Part	Option code
Body	H01
Seat	L59
Bonnet	L30
Cap / lever cover	L31
Disc	L23
Studs	N07
Nuts	N08

H01

L30

Documentation

6

Code and Medium

1 2
2 . 0

- 1 Code**
1. ASME Section VIII
 2. CE / VdTUEV
 3. ASME Section VIII + CE / VdTUEV

- 2 Medium**
- .1 Gases
 - .2 Liquids
 - .3 Steam
 - .0 Steam / Gases / Liquids (valid only for CE / VdTUEV)

2.0

Code and Medium

How to order – Article numbers

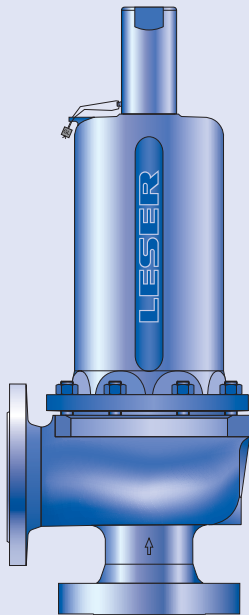

Type 456
Cap H2
Closed bonnet
Conventional design

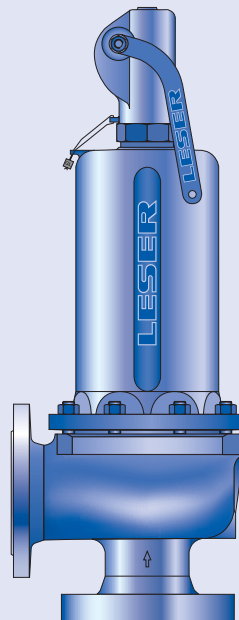

Type 456
Packed lever H4
Closed bonnet
Conventional design

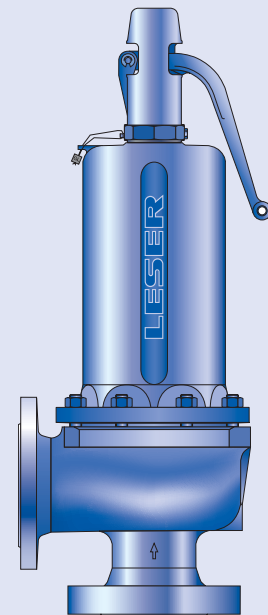

Type 456
Plain lever H3
Closed bonnet
Conventional design

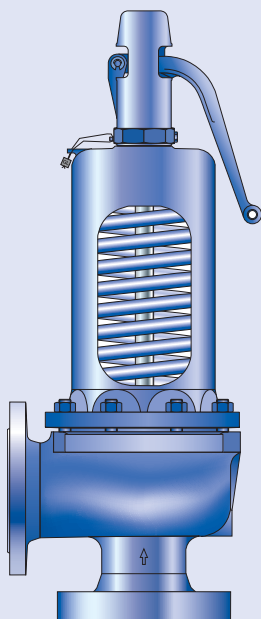

Type 455
Plain lever H3
Open bonnet
Conventional design

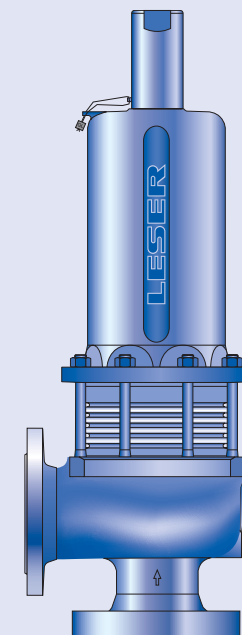

Type 456
Cap H2
Closed bonnet
Balanced bellows design

How to order – Article numbers

Article numbers						
		DN _{I+O}	25 x 50	50 x 80	80 x 100	100 x 150
		Valve size	1" x 2"	2" x 3"	3" x 4"	4" x 6"
		Actual Orifice diameter d ₀ [mm]	20	40	60	74
		Actual Orifice area A ₀ [mm ²]	314	1257	2827	4301
Body material: 1.0619 (WCB)						
Bonnet	H2	Art.-No. 4562.	6012	6022	6032	6042
closed	H3	Art.-No. 4562.	6013	6023	6033	-
	H4	Art.-No. 4562.	6014	6024	6034	6044
open	H3	Art.-No. 4552.	6015	6025	6035	6045
Body material: 1.4581 (CF10M)						
Bonnet	H2	Art.-No. 4564.	6052	6062	6072	6082
closed	H4	Art.-No. 4564.	6054	6064	6074	6084

Dimensions and weights

Metric Units

	DN _{in+o}	25 x 50	50 x 80	80 x 100	100 x 150
Valve size		1" x 2"	2" x 3"	3" x 4"	4" x 6"
Actual Orifice diameter d ₀ [mm]		20	40	60	74
Actual Orifice area A ₀ [mm ²]		314	1257	2827	4301
Weight [kg]		18	43	85	154
	with bellows	20	46	102	185
Center to face [mm]	Inlet a	122	155	168	205
	Outlet b (PN 40)	120	145	180	235
	Outlet b (PN 63)	120	145	205	265
Measure Used to find bolt length s [mm] for inlet flange		28	38	38	45
Height (H4) [mm]	Standard H max.	493	684	807	1059
	Bellows H max.	528	764	905	1150
Support brackets [mm]	A	140	184	278	364
	B	–	110	160	210
(drilled only on request)	C	Ø 14	Ø 14	Ø 18	Ø 18
	D	149	194	225	288
	E	18	18	27	32

Body material: 1.0619 (WCB)

DIN Flange¹⁾	Inlet	PN 63 – 160	
	Outlet	PN 40 – 63	PN 40

Body material: 1.4581 (CF10M)

DIN Flange¹⁾	Inlet	PN 63 – 160	
	Outlet	PN 40 – 63	PN 40

¹⁾ Standard flange rating. For other flange drillings and facings please refer to 08/14.

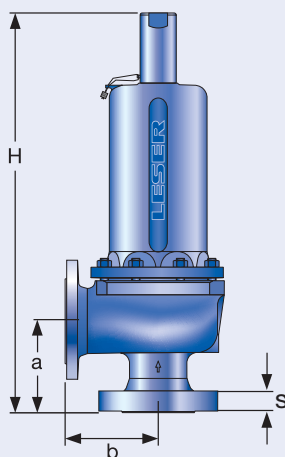

Conventional design

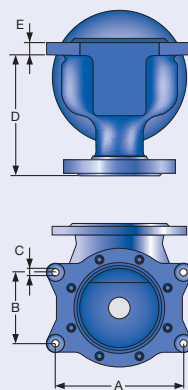

Support brackets

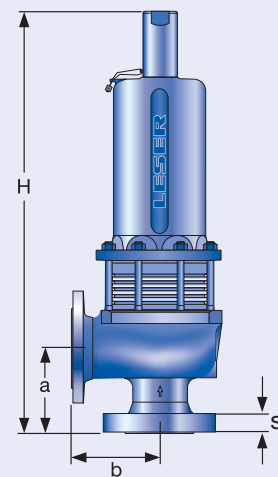

Balanced bellows design

Dimensions and weights

US Units		25 x 50	50 x 80	80 x 100	100 x 150
	DN _{in/o}	25 x 50	50 x 80	80 x 100	100 x 150
	Valve size	1" x 2"	2" x 3"	3" x 4"	4" x 6"
	Actual Orifice diameter d ₀ [inch]	0,79	1,57	2,36	2,91
	Actual Orifice area A ₀ [inch ²]	0,487	1,948	4,383	6,666
Weight		40	95	187	340
[lbs]	with bellows	44	101	225	408
Center to face	Inlet a	4 13/16	6 3/32	6 1/2	8 1/16
[mm]	Outlet b (PN 40)	4 23/32	5 23/32	7 3/32	9 1/4
	Outlet b (PN 63)	4 23/32	5 23/32	8 1/16	10 7/16
Measure	Used to find bolt length s for inlet flange	1 3/32	1 1/2	1 1/2	1 25/32
[mm]					
Height (H4)	Standard H max.	19 23/32	26 15/16	31 25/32	41 11/16
[mm]	Bellows H max.	20 25/32	30 3/32	35 5/8	45 1/4
Support brackets	A	5 1/2	7 1/4	10 5/16	4 11/32
[mm]	B	–	4 11/32	6 5/16	8 9/32
(drilled only on request)	C	Ø 9/16	Ø 9/16	Ø 23/32	Ø 23/32
	D	5 7/8	7 5/8	8 27/32	11 11/32
	E	23/32	23/32	1 1/16	1 1/4
Body material: 1.0619 (WCB)					
ANSI Flange Class¹⁾	Inlet	CL300 – 600			
	Outlet	CL150 – 300		CL150	
Body material: 1.4581 (CF10M)					
ANSI Flange Class¹⁾	Inlet	CL300 – 600			
	Outlet	CL150 – 300		CL150	

¹⁾ Standard flange rating. For other flange drillings and facings please refer to 08/14.

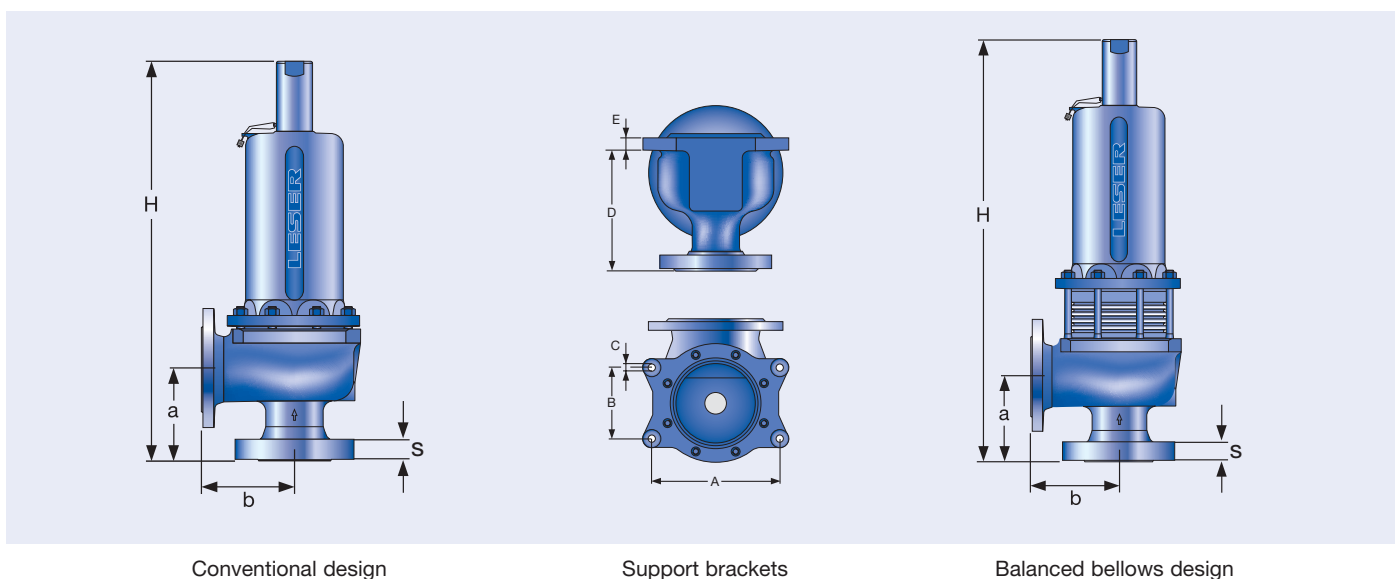

Conventional design

Support brackets

Balanced bellows design

Pressure temperature ratings

Metric Units

DN _{i,o}	25 x 50	50 x 80	80 x 100	100 x 150
Valve size	1" x 2"	2" x 3"	3" x 4"	4" x 6"
Actual Orifice diameter d ₀ [mm]	20	40	60	74
Actual Orifice area A ₀ [mm ²]	314	1257	2827	4301

Body material: 1.0619 (WCB)

DIN Flange	Inlet		PN 63 – 100			
	Outlet		PN 40 – 63	PN 40		
Minimum set pressure	p [bar _g]	S/G/L	2,5	2,5	2,5	2,5
Min. set pressure¹⁾ standard bellows	p [bar _g]	S/G/L	13,5	2,5	10	5
Min. set pressure low press. bellows	p [bar _g]	S/G/L	on request			
Maximum set pressure	p [bar _g]	S/G/L	100	98	63	53
Max. set pressure with special spring	p [bar _g]	S/G/L	100	100	63	63
Temperature acc. to DIN EN	min. [°C]		-85			
	max. [°C]		+450			
Temperature acc. to ASME	min. [°C]		-29			
	max. [°C]		+427			

Body material: 1.4581 (CF10M)

DIN Flange	Inlet		PN 63 – 100			
	Outlet		PN 40 – 63	PN 40		
Minimum set pressure	p [bar _g]	S/G/L	2,5	2,5	2,5	2,5
Min. set pressure¹⁾ standard bellows	p [bar _g]	S/G/L	13,5	2,5	10	5
Min. set pressure low press. bellows	p [bar _g]	S/G/L	on request			
Maximum set pressure	p [bar _g]	S/G/L	100	61	35	16,9
Max. set pressure with special spring	p [bar _g]	S/G/L	100	65	43	43
Temperature acc. to DIN EN	min. [°C]		-85			
	max. [°C]		+450, > 450 °C → Please use Type 457/458			
Temperature acc. to ASME	min. [°C]		-29			
	max. [°C]		+450, > 450 °C → Please use Type 457/458			

¹⁾ Min. set pressure standard bellows = Max. set pressure low pressure bellows.

Pressure temperature ratings

US Units					
	DN _{I+O}	25 x 50	50 x 80	80 x 100	100 x 150
	Valve size	1" x 2"	2" x 3"	3" x 4"	4" x 6"
	Actual Orifice diameter d ₀ [inch]	0,79	1,57	2,36	2,91
	Actual Orifice area A ₀ [inch ²]	0,487	1,948	4,383	6,666
Body material: 1.0619 (WCB)					
ANSI Flange Class ¹⁾	Inlet		CL300 – 600		
	Outlet		CL150 – 300		CL150
Minimum set pressure	p [psig]	S/G/L	36	36	36
Min. set pressure²⁾ standard bellows	p [psig]	S/G/L	196	36	145
Min. set pressure low press. bellows	p [psig]	S/G/L	on request		
Maximum set pressure	p [psig]	S/G/L	1450	1421	914
Max. set pressure with special spring	p [psig]	S/G/L	1450	1450	914
Temperature acc. to DIN EN	min. [°F]		-121		
	max. [°F]		+842		
Temperature acc. to ASME	min. [°F]		-20		
	max. [°F]		+800		
Body material: 1.4581 (CF10M)					
ANSI Flange Class ¹⁾	Inlet		CL300 – 600		
	Outlet		CL150 – 300		CL150
Minimum set pressure	p [psig]	S/G/L	36	36	36
Min. set pressure²⁾ standard bellows	p [psig]	S/G/L	196	36	145
Min. set pressure low press. bellows	p [psig]	S/G/L	on request		
Maximum set pressure	p [psig]	S/G/L	1450	885	508
Max. set pressure with special spring	p [psig]	S/G/L	1450	943	624
Temperature acc. to DIN EN	min. [°F]		-121		
	max. [°F]		+842, > 842 °F → Please use Type 457/458		
Temperature acc. to ASME	min. [°F]		-20		
	max. [°F]		+842, > 842 °F → Please use Type 457/458		

¹⁾ For flange rating class 150 the pressure temperature ratings according to ASME ANSI B 16.34 apply.

²⁾ Min. set pressure standard bellows = Max. set pressure low pressure bellows.

Flange drillings and facings

Flange drillings

	DN _{r,o}	25 x 50	50 x 80	80 x 100	100 x 150		
Valve size		1" x 2"	2" x 3"	3" x 4"	4" x 6"		
Actual Orifice diameter d ₀ [mm]		20	40	60	74		
Actual Orifice area A ₀ [mm ²]		314	1257	2827	4301		
Body material: 1.0619 (WCB), 1.4581 (CF10M)							
Inlet	DIN EN 1092	PN 16	H47	H47	H47	H47	
		PN 25	H47	H47	H47	H47	
		PN 40	H47	H47	H47	H47	
		PN 63	*	H10	H10	H10	
		PN 100	*	*	*	*	
		PN 160	*	*	*	*	
		PN 250	-	-	-	-	
		PN 320	-	-	-	-	
		PN 400	-	-	-	-	
	ASME B16.5	CL150	-	-	-	-	
		CL300	H65	H65	H65	H65	
		CL600	H67	H67	H67	H67	
		CL900	H69	H69	-	-	
		CL1500	H69	H69	-	-	
		CL2500	-	-	-	-	
	Outlet	DIN EN 1092	PN 10	*	*	H51	H51
			PN 16	*	*	H51	H51
			PN 25	*	*	*	*
			PN 40	*	*	*	*
PN 63			H16	H16	-	-	
ASME B16.5		CL150	H79	H79	H79	H79	
		CL300	H80	H80	-	-	

Flange facings

Indication	Standard	Inlet	Outlet	Remark						
General										
Flange undrilled	-	H38	H39							
Linde-V-Nut, Form V48	Linde Standard 420-08	J07	J08	Groove: Rz 16						
Linde-V-Nut, Form V48A	LWN 313.36	J05	J06	Groove: Rz 4, e.g. with hydrogen						
Lens seal form L (without sealing lens)	DIN 2696 LWN 313.35	J11	J12							
Acc. to DIN EN										
Flange facing		Inlet		Outlet	Remark					
DIN EN 1092 (new)		DIN 2526 (old)								
see also LWN 313.40)		PN 10 – PN 40	PN 63 – PN 400	PN 10 – PN 40	PN 63	Rz-data according to DIN EN 1092 in µm				
Raised face	Type B1	Type C	*	-	*	-	Facing: Rz = 12,5 – 50			
		Type D								
	Type B2	Type E	L36	*	L38	*	Facing: Rz = 3,2 – 12,5			
Tongue face C ¹⁾		Tongue face F		H94		H92				
Groove face D		Groove face N		H93		H91				
Male face E		Male face V13		H96		H98				
Female face F		Female face R13		H97		H99				
O-ring male face G		Male face V14		J01		J02				
O-ring female face H		Female face R14		J03		J04				
Acc. to ASME B16.5										
Body material	Inlet	Outlet	Smooth finish²⁾		Serrated finish		RTJ-groove			
			Inlet	Outlet	Inlet	Outlet	Inlet		Outlet	
			Option code	Option code	Option code	Option code	RTJ-Class	Option code	RTJ-Class	Option code
1.0619, 1.4581	all	all	L52	L53	*	*	CL300 – 1500	H62	CL150	H63
							CL2500	-	CL300	H63

¹⁾ According to DIN EN 1092 groove depths and tongue heights increased compared to the formerly valid DIN (refer to LWN 313.40).

LESER manufactures the groove at flanged valves by milling. If a customer demands a turned surface in the soil of the groove according to DIN 2512 and/or DIN EN 1092-1 an additional option code is necessary: "S01: bottom of the groove drilled". Groove and tongue for PN160 flanges refer to DIN 2512/LWN 313.32.

²⁾ Smooth finish is not defined in the effective standards. For LESER's definition for smooth finish see page 00/07.

For signs and symbols refer to page 00/07

Note: Flange drillings and facings meet always the requirements of mentioned flange standards. Flange thickness and outer diameter may vary from flange standard.

Order information – Spare parts

Spare parts					
	DN _{ISO}	25 x 50	50 x 80	80 x 100	100 x 150
	Valve size	1" x 2"	2" x 3"	3" x 4"	4" x 6"
	Actual Orifice diameter d ₀ [mm]	20	40	60	74
	Actual Orifice area A ₀ [mm ²]	314	1257	2827	4301
Disc (Item 7): Metal to metal seat					
		Material-No. / Art.-No.			
Disc	1.4122	200.0239.9000	200.0439.9000	200.0639.9000	200.0939.9000
with detachable lifting aid	1.4404	200.0269.9000	200.0469.9000	200.0669.9000	200.0969.9000
Disc (Item 7): Soft seal					
		Material-No. / Art.-No.			
Disc	CR	"K"	–	–	–
	EPDM	"D"	–	–	–
	FKM	"L"	200.1149.9073	200.1349.9073	200.1549.9073
	FFKM	"C"	–	–	–
Disc (Item 7.4): Soft seal					
		Material-No. / Art.-No.			
O-ring	CR	"K"	–	–	–
	EPDM	"D"	–	–	–
	FKM	"L"	200.1149.9073	200.1349.9073	200.1549.9073
	FFKM	"C"	–	–	–
Bellows (Item 15)					
		Material-No. / Art.-No.			
Standard bellows		400.5749.0000	400.5949.0000	400.6149.0000	400.6249.0000
Conversion kit standard¹⁾		on request	on request	on request	on request
Low pressure bellows		on request	on request	on request	on request
Conversion kit low pressure¹⁾		on request	on request	on request	on request
Gasket – body / bonnet (Item 60)					
		Material-No. / Art.-No.			
Gasket	Graphite + 1.4401	500.1007.0000	500.1607.0000	500.2107.0000	500.2207.0000
Option code L68	Gylon (filled PTFE)	500.1005.0000	500.1605.0000	500.2105.0000	500.2205.0000
Ball (Item 61)					
		Material-No. / Art.-No.			
Ball	Ball Ø [mm]	9	12	15	15
	1.4401	510.0204.0000	510.0304.0000	510.0404.0000	510.0404.0000
Split ring (Item 14)					
		Material-No. / Art.-No.			
Split ring	Spindle Ø [mm]	16	20	24	30
	1.4404	251.0249.0000	251.0349.0000	251.0449.0000	251.0549.0000
Ball (Item 57)					
		Material-No. / Art.-No.			
Ball (15 pieces)	Ball Ø [mm]	3	3	3	3
	1.4310	510.0604.0000	510.0604.0000	510.0604.0000	510.0604.0000
Screw (Item 66)					
		Material-No. / Art.-No.			
Screw	1.4401	451.0114.0000	451.0114.0000	451.0114.0000	451.0114.0000

¹⁾ For pressure range see page 08/12 – 08/13.
A conversion kit contains the following components:

Item	Component	No.
8	Guide	1
11	Bonnet spacer	1
12	Spindle	1
15	Bellows	1
55	Stud	4, 8 depends on valve size
60	Gasket	2, 3 depends on valve size
	Installation instruction LWN 037.05	1

Refer to page 08/04

Available Options

For further information refer to
"Accessories and Options", page 99/01

Heating jacket

H29, H30: Couplings G 3/8, G 3/4
H31, H32: Flanges DN 15, DN 25

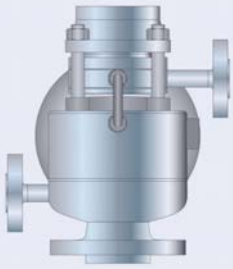

Drain hole

J18: G 1/4
J19: G 1/2

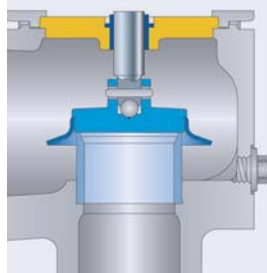

Open bonnet

See Art.-No.

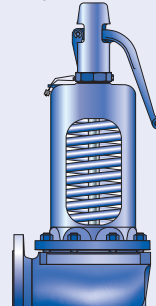

O-ring-disc

J20: FFKM "C"
J21: CR "K"
J22: EPDM "D"
J23: FKM "L"

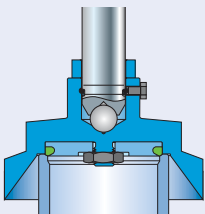

Stainless steel bellows

J68: Open bonnet
J78: Closed bonnet

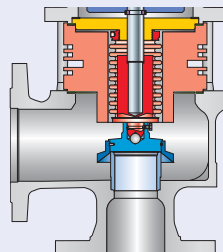

Conversion kit for stainless steel bellows

on request

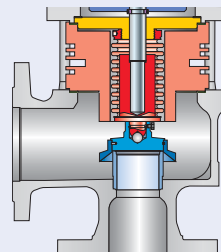

Screwed cap H2

H2

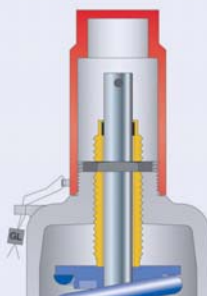

Plain lever H3

H3



Packed lever H4

H4

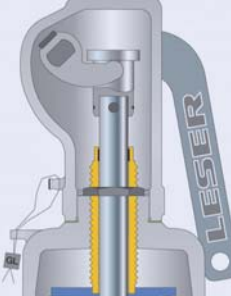

Test gag

J69: H4
J70: H2

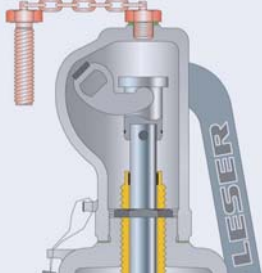

Lift indicator

J39: Adaptor H4
J93: Lift indicator

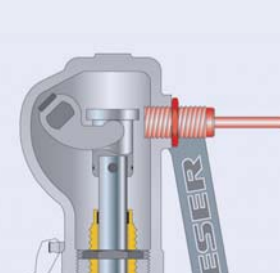

O-ring-damper H2

J65

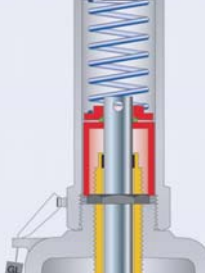

O-ring-damper H4

J66

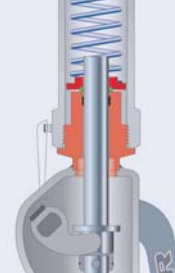

Approvals

Approvals					
	DN _{I+O}	25 x 50	50 x 80	80 x 100	100 x 150
	Valve size	1" x 2"	2" x 3"	3" x 4"	4" x 6"
	Actual Orifice diameter d ₀ [mm]	20	40	60	74
	Actual Orifice area A ₀ [mm ²]	314	1257	2827	4301
Europe		Coefficient of discharge K _{dr}			
DIN EN ISO 4126-1	Approval No.	072020111Z0008/0/11			
	S/G	0,8	0,8	0,75	0,8
	L	0,6	0,54	0,5	0,56
Germany		Coefficient of discharge C _w			
AD 2000-Merkblatt A2	Approval No.	TÜV SV 934			
	S/G	0,8	0,8	0,75	0,8
	L	0,6	0,54	0,5	0,56
United States		Coefficient of discharge K			
ASME Sec. VIII	Approval No.	M37066	M37066	M37088	M37066
	S/G	0,798	0,798	0,754	0,798
	Approval No.	M37077	M37077	M37099	M37077
	L	0,572	0,572	0,479	0,572
Canada		Coefficient of discharge K			
Canada: CRN	Approval No.	-			
	S/G	0,798	0,798	0,754	0,798
	L	0,572	0,572	0,479	0,572
China		Coefficient of discharge C _w			
CSBQTS	Approval No.				
	S/G	0,8	0,8	0,75	0,8
	L	0,6	0,54	0,5	0,56
Russia		Coefficient of discharge C _w			
GGTN/ GOSGORTECHNADZOR	Approval No.	PPC 00-18458			
GOST R	Approval No.	1989-06			
	S/G	0,8	0,8	0,75	0,8
	L	0,6	0,54	0,5	0,56
Belarus		Coefficient of discharge K			
PROMATOMNADZOR	Approval No.	15-171-2006			
	S/G	0,8	0,8	0,75	0,8
	L	0,6	0,54	0,5	0,56
Classification societies					
on request					

Capacities – Steam

Capacities for saturated steam according to AD 2000-Merkblatt A2, based on set pressure plus 10 % overpressure.
Capacities at 1 bar (14,5 psig) and below are based on 0,1 bar (1,45 psig) overpressure.

Metric Units	AD 2000-Merkblatt A2 [kg/h]			
DN _{I+O}	25 x 50	50 x 80	80 x 100	100 x 150
Valve size	1" x 2"	2" x 3"	3" x 4"	4" x 6"
Actual Orifice diameter d ₀ [mm]	20	40	60	74
Actual Orifice area A ₀ [mm ²]	314	1257	2827	4301
LEO _{S/G} *) [inch ²]	0,399	1,594	3,389	5,456
Set pressure [bar]	Capacities [kg/h]			
2,5	509	2036	4403	7149
3	589	2385	5094	8265
4	743	3011	6352	10306
5	901	3605	7604	12338
6	1049	4197	8853	14363
7	1194	4774	10070	16339
8	1340	5362	11310	18351
9	1487	5949	12548	20360
10	1634	6535	13785	22367
12	1927	7707	16257	26378
14	2214	8855	18678	30306
16	2506	10024	21145	34308
18	2799	11195	23615	38316
20	3092	12368	26089	42330
22	3376	13506	28489	46224
24	3670	14681	30967	50245
26	3965	15859	33452	54276
28	4260	17040	35943	58319
30	4556	18225	38443	62374
32	4853	19414	40950	66443
34	5137	20549	43345	70328
36	5436	21743	45863	74414
38	5735	22941	48391	78515
40	6036	24144	50929	82632
50	7559	30235	63777	103480
60	9091	36366	76709	124462
70	10686	42745		
80	12293	49171		
90	13983	55932		
100	15689	62756		

Capacities for saturated steam according to ASME Section VIII (UV), based on set pressure plus 10% overpressure.
Capacities at 2,07 bar (30 psig) and below are based on 0,207 bar (3 psig) overpressure.

US Units	ASME Section VIII [lb/h]			
DN _{I+O}	25 x 50	50 x 80	80 x 100	100 x 150
Valve size	1" x 2"	2" x 3"	3" x 4"	4" x 6"
Actual Orifice diameter d ₀ [inch]	0,79	1,57	2,36	2,91
Actual Orifice area A ₀ [inch ²]	0,487	1,948	4,383	6,666
LEO _{S/G} *) [inch ²]	0,399	1,594	3,389	5,456
Set pressure [psig]	Capacities [lb/h]			
15	654	2614	5557	8947
20	754	3014	6408	10317
30	954	3815	8110	13056
40	1174	4695	9982	16070
50	1394	5576	11854	19083
60	1614	6456	13726	22097
70	1834	7337	15598	25111
80	2054	8217	17470	28124
90	2275	9098	19342	31138
100	2495	9979	21214	34152
120	2935	11740	24958	40179
140	3375	13501	28702	46206
160	3815	15262	32446	52233
180	4256	17023	36189	58261
200	4696	18784	39933	64288
220	5136	20545	43677	70315
240	5577	22306	47421	76342
260	6017	24067	51165	82370
280	6457	25828	54909	88397
300	6897	27589	58653	94424
320	7338	29350	62397	100451
340	7778	31111	66141	106478
360	8218	32872	69885	112506
380	8658	34633	73629	118533
400	9099	36395	77373	124560
500	11300	45200	96092	154696
600	13501	54005	114812	184833
700	15703	62810	133531	214969
800	17904	71616	152251	245105
900	20105	80421	170970	275241
1000	22307	89226		
1100	24508	98032		
1200	26709	106837		
1300	28911	115642		
1400	31068	124273		
1450	32265	129061		

*) LEO_{S/G} = LESER Effective Orifice steam/gas please refer to page 00/11
How to use capacity-sheets refer to page 00/09

Capacities – Air

Capacities for air according to AD 2000-Merkblatt A2, based on set pressure plus 10 % overpressure at 0 °C and 1013 mbar.
Capacities at 1 bar (14,5 psig) and below are based on 0,1 bar (1,45 psig) overpressure.

Capacities for air according to ASME Section VIII (UV), based on set pressure plus 10% overpressure at 16 °C (60°F).
Capacities at 2,07 bar (30 psig) and below are based on 0,207 bar (3 psig) overpressure.

Metric Units	AD 2000-Merkblatt A2 [m ³ /h]				
	DN _{I+O}	25 x 50	50 x 80	80 x 100	100 x 150
Valve size	1" x 2"	2" x 3"	3" x 4"	4" x 6"	
Actual Orifice diameter d ₀ [mm]	20	40	60	74	
Actual Orifice area A ₀ [mm ²]	314	1257	2827	4301	
LEO _{S/G} *) [inch ²]	0,399	1,594	3,389	5,456	
Set pressure [bar]	Capacities [m ³ /h]				
2,5	619	2478	5357	8700	
3	719	2914	6224	10098	
4	914	3704	7812	12676	
5	1114	4457	9401	15253	
6	1302	5210	10989	17830	
7	1491	5963	12578	20407	
8	1679	6716	14166	22985	
9	1867	7469	15755	25562	
10	2055	8222	17343	28139	
12	2432	9728	20520	33294	
14	2809	11234	23697	38449	
16	3185	12740	26874	43603	
18	3562	14246	30051	48758	
20	3938	15752	33228	53912	
22	4315	17258	36404	59067	
24	4691	18764	39581	64221	
26	5068	20271	42758	69376	
28	5444	21777	45935	74531	
30	5821	23283	49112	79685	
32	6197	24789	52289	84840	
34	6574	26295	55466	89994	
36	6950	27801	58643	95149	
38	7327	29307	61820	100304	
40	7703	30813	64997	105458	
50	9586	38344	80881	131231	
60	11469	45874	96766	157004	
70	13351	53404			
80	15234	60935			
90	17116	68465			
100	18999	75996			

US Units	ASME Section VIII [S.C.F.M.]				
	DN _{I+O}	25 x 50	50 x 80	80 x 100	100 x 150
Valve size	1" x 2"	2" x 3"	3" x 4"	4" x 6"	
Actual Orifice diameter d ₀ [inch]	0,79	1,57	2,36	2,91	
Actual Orifice area A ₀ [inch ²]	0,487	1,948	4,383	6,666	
LEO _{S/G} *) [inch ²]	0,399	1,594	3,389	5,456	
Set pressure [psig]	Capacities [S.C.F.M.]				
15	233	931	1980	3187	
20	268	1074	2283	3675	
30	340	1359	2889	4651	
40	418	1673	3556	5724	
50	497	1986	4223	6798	
60	575	2300	4890	7871	
70	653	2614	5557	8945	
80	732	2928	6224	10018	
90	810	3241	6891	11091	
100	889	3555	7558	12165	
120	1046	4182	8891	14312	
140	1202	4810	10225	16459	
160	1359	5437	11559	18606	
180	1516	6065	12893	20753	
200	1673	6692	14227	22900	
220	1830	7319	15560	25047	
240	1987	7947	16894	27193	
260	2144	8574	18228	29340	
280	2300	9202	19562	31487	
300	2457	9829	20896	33634	
320	2614	10456	22229	35781	
340	2771	11084	23563	37928	
360	2928	11711	24897	40075	
380	3085	12338	26231	42222	
400	3241	12966	27565	44369	
500	4026	16103	34234	55104	
600	4810	19240	40903	65838	
700	5594	22377	47572	76573	
800	6378	25514	54241	87307	
900	7163	28651	60910	98042	
1000	7947	31788	67579	108777	
1100	8731	34925	74248	119511	
1200	9515	38062	80917	130246	
1300	10300	41199	87586	140981	
1400	11084	44336	94255	151715	
1450	11476	45904	97589	157083	

*) LEO_{S/G} = LESER Effective Orifice steam/gas please refer to page 00/11
How to use capacity-sheets refer to page 00/09

Capacities – Water

Capacities for water according to AD 2000-Merkblatt A2, based on set pressure plus 10 % overpressure at 20 °C (68 °F).

Capacities at 1 bar (14,5 psig) and below are based on 0,1 bar (1,45 psig) overpressure..

Capacities for water according to ASME Section VIII (UV), based on set pressure plus 10 % overpressure at 21 °C (70 °F).

Capacities at 2,07 bar (30 psig) and below are based on 0,207 bar (3 psig) overpressure.

Metric Units	AD 2000-Merkblatt A2 [10 ³ kg/h]			
DN _{I+O}	25 x 50	50 x 80	80 x 100	100 x 150
Valve size	1" x 2"	2" x 3"	3" x 4"	4" x 6"
Actual Orifice diameter d ₀ [mm]	20	40	60	74
Actual Orifice area A ₀ [mm ²]	314	1257	2827	4301
LEO _L ^{*)} [inch ²]	0,399	1,594	3,389	5,456
Set pressure [bar]	Capacities [10 ³ kg/h]			
2,5	15,9	57,2	119	203
3	17,4	62,7	131	223
4	20,1	72,4	151	257
5	22,5	80,9	169	287
6	24,6	88,7	185	315
7	26,6	95,8	200	340
8	28,4	102	213	363
9	30,2	109	226	385
10	31,8	114	238	406
12	34,8	125	261	445
14	37,6	135	282	481
16	40,2	145	302	514
18	42,7	154	320	545
20	45	162	337	575
22	47,2	170	354	603
24	49,3	177	369	629
26	51,3	185	385	655
28	53,2	192	399	680
30	55,1	198	413	704
32	56,9	205	427	727
34	58,6	211	440	749
36	60,3	217	452	771
38	62	223	465	792
40	63,6	229	477	813
50	71,1	256	533	909
60	77,9	280	584	995
70	84,1	303		
80	89,9	324		
90	95,4	343		
100	101	362		

US Units	ASME Section VIII [US-G.P.M.]			
DN _{I+O}	25 x 50	50 x 80	80 x 100	100 x 150
Valve size	1" x 2"	2" x 3"	3" x 4"	4" x 6"
Actual Orifice diameter d ₀ [inch]	0,79	1,57	2,36	2,91
Actual Orifice area A ₀ [inch ²]	0,487	1,948	4,383	6,666
LEO _L ^{*)} [inch ²]	0,399	1,594	3,389	5,456
Set pressure [psig]	Capacities [US-G.P.M.]			
15	44,8	179	338	614
20	50,7	203	382	694
30	60,7	243	458	831
40	70,1	280	528	960
50	78,4	314	591	1073
60	85,9	343	647	1175
70	92,8	371	699	1270
80	99,2	397	747	1357
90	105	421	793	1440
100	111	443	836	1517
120	121	486	915	1662
140	131	525	989	1795
160	140	561	1057	1919
180	149	595	1121	2036
200	157	627	1182	2146
220	164	658	1239	2251
240	172	687	1294	2351
260	179	715	1347	2447
280	186	742	1398	2539
300	192	768	1447	2628
320	198	793	1495	2714
340	204	818	1541	2798
360	210	841	1585	2879
380	216	864	1629	2958
400	222	887	1671	3035
500	248	992	1868	3393
600	272	1086	2047	3717
700	293	1173	2211	4015
800	314	1254	2363	4292
900	333	1330	2507	4552
1000	351	1402	2642	4799
1100	368	1471	2771	5033
1200	384	1536	2894	5257
1300	400	1599	3012	5471
1400	415	1659	3126	5678
1450	422	1689	3182	5778

*) LEO_L = LESER Effective Orifice liquids please refer to page 00/12

How to use capacity-sheets refer to page 00/09

Determination of coefficient of discharge in case of lift restriction or back pressure

- h = Lift [mm]
- d₀ = Flow diameter [mm] of selected safety valve, refer to table article numbers
- h/d₀ = Ratio of lift / flow diameter
- p_{a0} = Back pressure [bar_a]
- p₀ = Set pressure [bar_a]
- p_{a0}/p₀ = Ratio of back pressure / set pressure
- K_{dr} = Coefficient of discharge acc. to DIN EN ISO 4126-1
- α_w = Coefficient of discharge acc. to AD 2000-Merkblatt A2
- K_b = Back pressure correction factor acc. to API 520 topic 3.3

Diagram for evaluation of ratio of lift / flow diameter (h/d₀) in reference to the coefficient of discharge (K_{dr}/α_w)

DN 25, d₀ 20

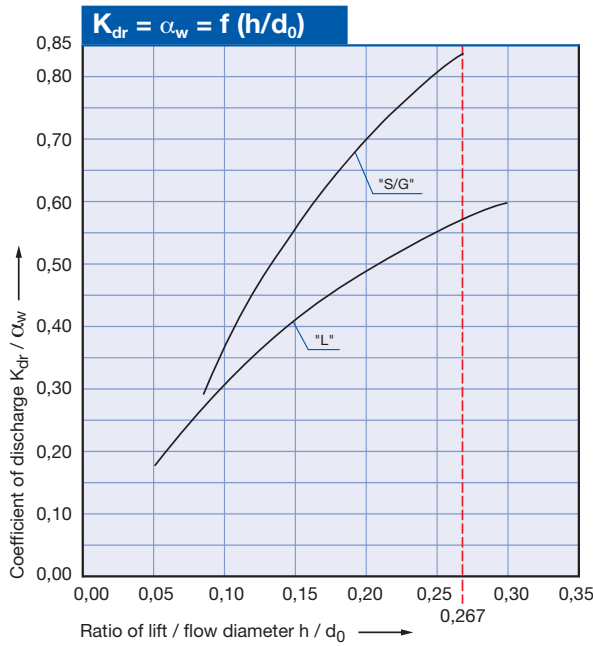

DN 50, d₀ 40

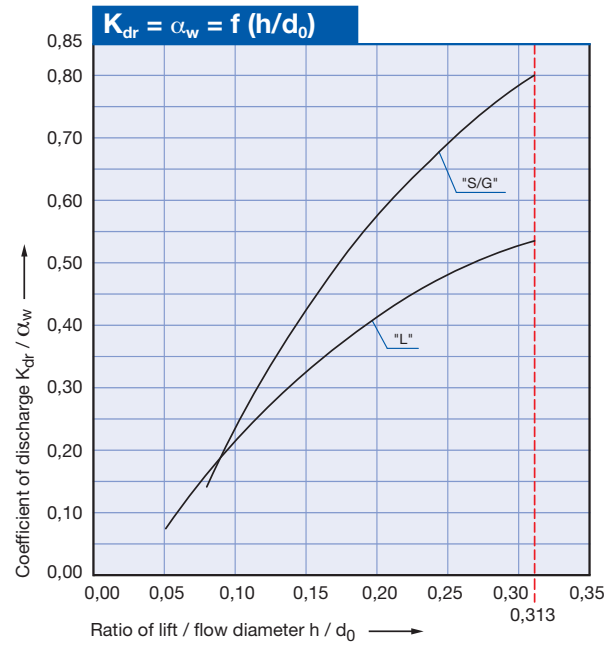
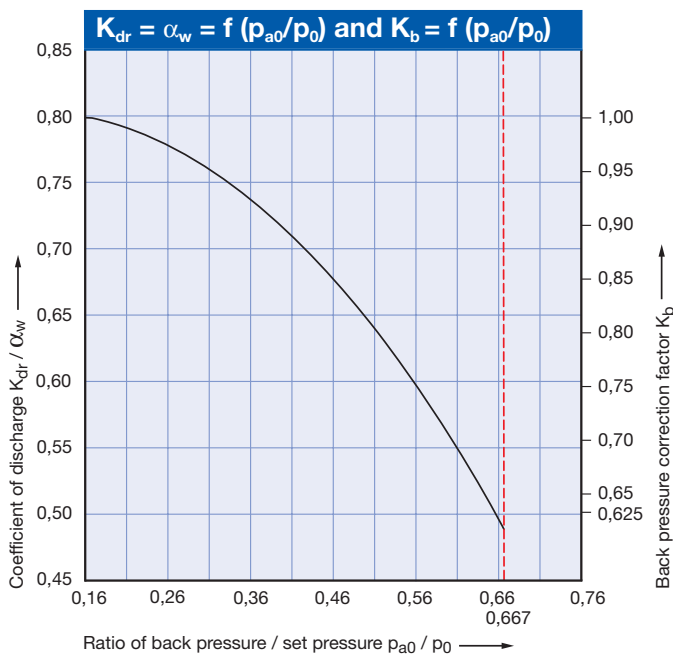
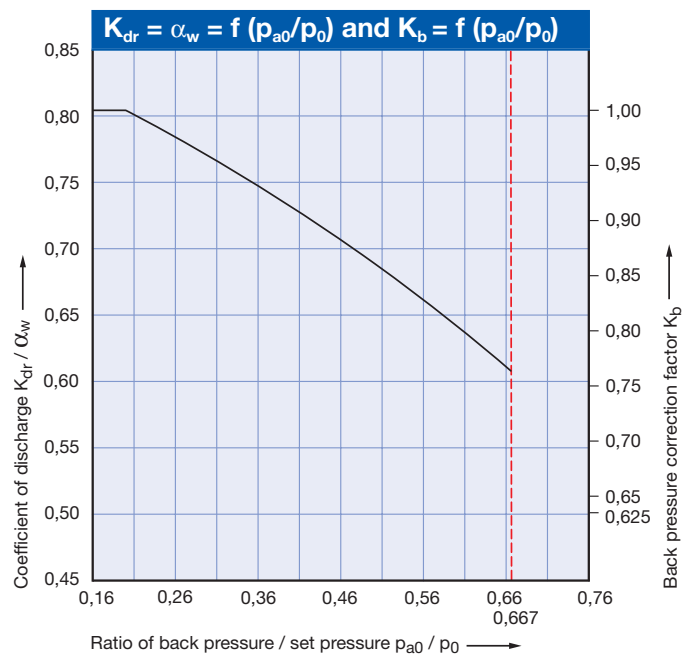

Diagram for evaluation of coefficient of discharge (K_{dr}/α_w) or K_b in reference to the ratio of back pressure / set pressure (p_{a0}/p₀)

DN 25, d₀ 20



DN 50, d₀ 40



How to use please refer to page 00/08

Determination of coefficient of discharge in case of lift restriction or back pressure

- h = Lift [mm]
- d₀ = Flow diameter [mm] of selected safety valve, refer to table article numbers
- h/d₀ = Ratio of lift / flow diameter
- p_{a0} = Back pressure [bar_a]
- p₀ = Set pressure [bar_a]
- p_{a0}/p₀ = Ratio of back pressure / set pressure
- K_{dr} = Coefficient of discharge acc. to DIN EN ISO 4126-1
- α_w = Coefficient of discharge acc. to AD 2000-Merkblatt A2
- K_b = Back pressure correction factor acc. to API 520 topic 3.3

Diagram for evaluation of ratio of lift / flow diameter (h/d₀) in reference to the coefficient of discharge (K_{dr}/α_w)

DN 80, d₀ 60

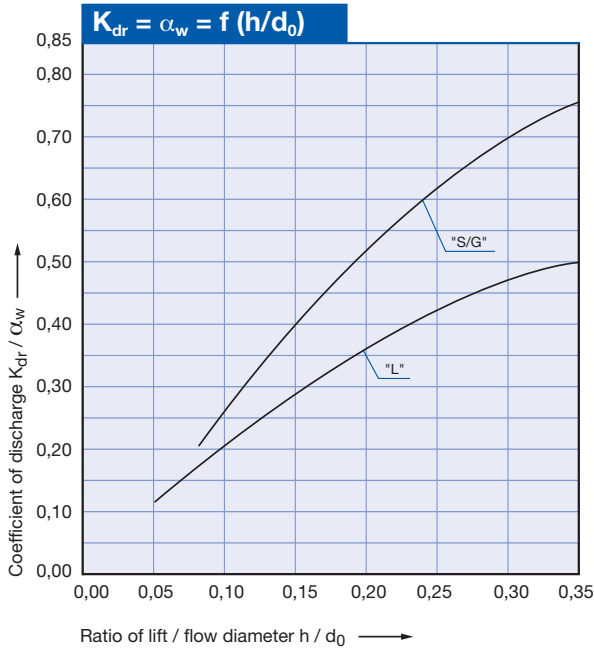

DN 100, d₀ 74

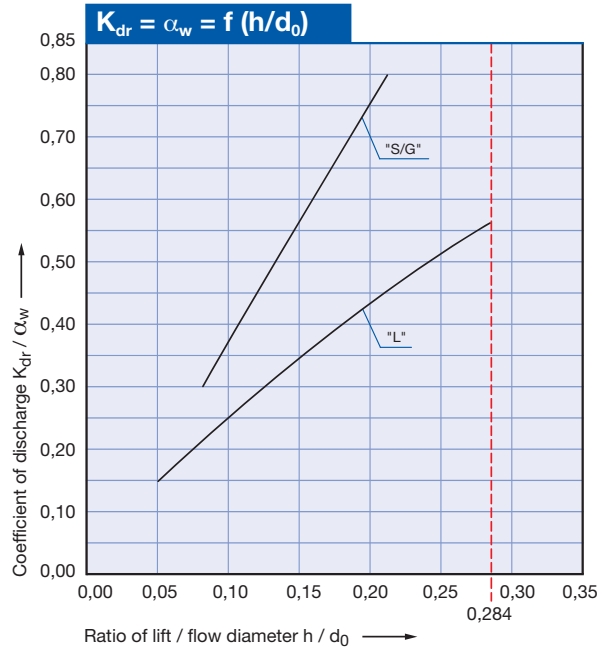
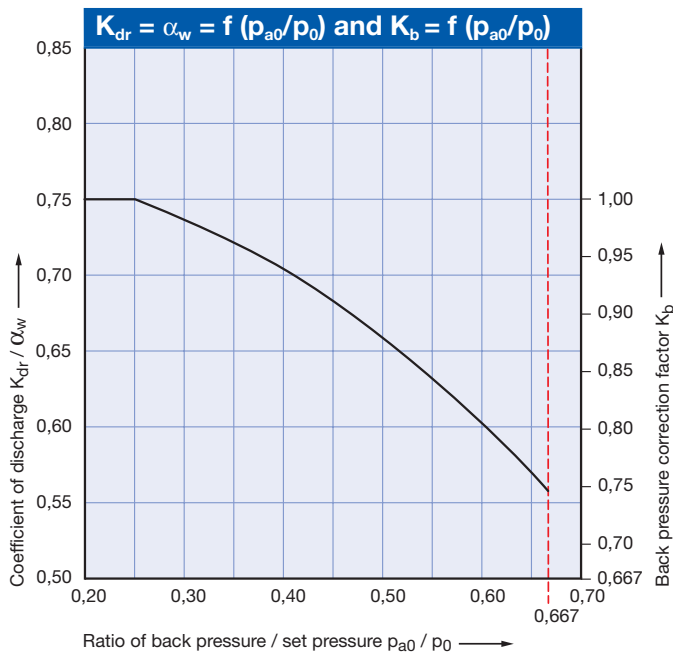
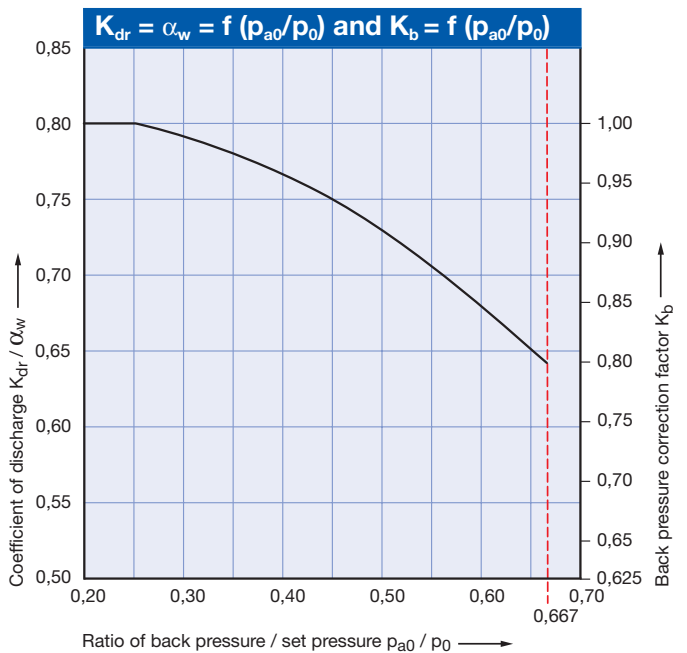

Diagram for evaluation of coefficient of discharge (K_{dr}/α_w) or K_b in reference to the ratio of back pressure / set pressure (p_{a0}/p₀)

DN 80, d₀ 60



DN 100, d₀ 74



How to use please refer to page 00/08

Type 457, 458

Type 458
Packed lever H4
Closed bonnet
Conventional design



Flanged Safety Relief Valves – spring loaded

Contents

Chapter/Page

Materials

- Conventional design 09/02
- Balanced bellows design 09/04

How to order

- Numbering system 09/06
- Article numbers 09/08

Dimensions and weights

- Metric Units 09/10
- US Units 09/11

Pressure temperature ratings

- Metric Units 09/12
- US Units 09/13

Flange drillings and facings 09/14

Order information – Spare parts 09/16

Available options 09/18

Approvals 09/19

Capacities

- Steam [Metric Units + US Units] 09/20
- Air [Metric Units + US Units] 09/22
- Water [Metric Units + US Units] 09/24

Determination of coefficient 09/26

of discharge K_{dr}/α_w

Conventional design

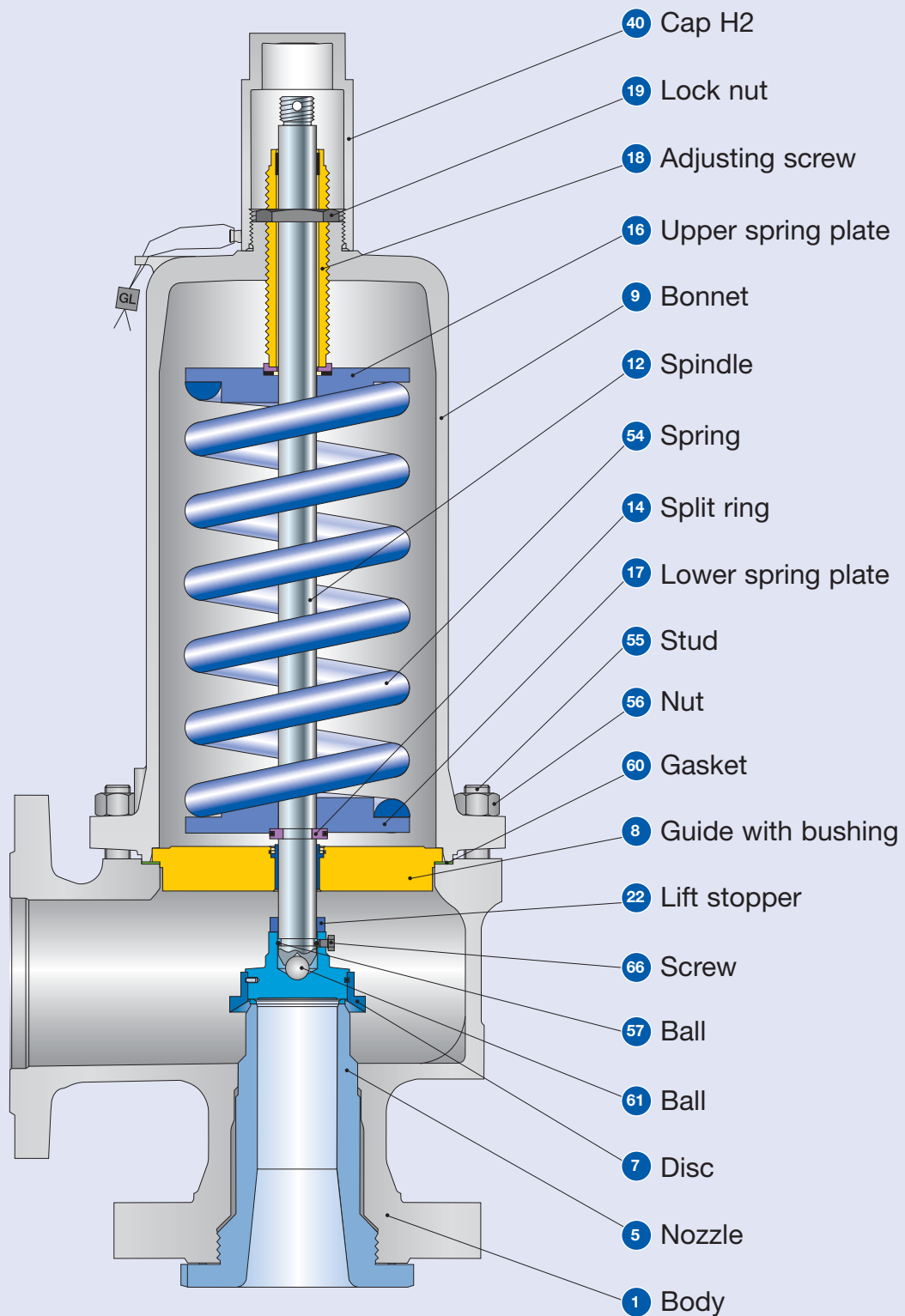

Conventional design

Materials				
Item	Component	Type 4572 / 4582	Type 4577 / 4587	Type 4584
1	Body	1.0619	1.7357	1.4581
		SA 216 WCB	SA 217 WC6	SA 351 CF10M
5	Nozzle	1.4404	1.4404 stellited	1.4404
		316L	316L	316L
7	Disc	1.4122	1.4122	1.4404
		Hardened stainless steel	Hardened stainless steel	316L
8	Guide with bushing	1.0501, 0.7040	1.0501, 0.7040	1.4404
		Chrome or carbon steel	Chrome or carbon steel	316L
		1.4104 tenifer Chrome steel	1.4104 tenifer Chrome steel	-
9	Bonnet	0.7043 (Open bonnet 0.7040), 1.0619	0.7043 (Open bonnet 0.7040), 1.0619	1.4408, 1.4404, 1.4571
		Ductile Gr. 60-40-18, SA 216 WCB	Ductile Gr. 60-40-18, SA 216 WCB	SA 351 CF8M, SA 479 316L, 316Ti
12	Spindle	1.4404	1.4404	1.4404
		316L	316L	316L
14	Split ring	1.4104	1.4104	1.4404
		Chrome steel	Chrome steel	316L
16 / 17	Spring plate	1.0718	1.0718	1.4404
		Steel	Steel	316L
18	Adjusting screw with bushing	1.4104 PTFE	1.4104 PTFE	1.4404 PTFE
		Chrome steel PTFE	Chrome steel PTFE	316L PTFE
19	Lock nut	1.0718	1.0718	1.4404
		Steel	Steel	316L
22	Lift stopper	1.4404	1.4404	1.4404
		316L	316L	316L
40	Cap H2	1.0718	1.4404	1.4404
		12L13	316L	316L
54	Spring standard	1.1200, 1.8159, 1.7102	1.1200, 1.8159, 1.7102	1.4310
		Carbon steel	Carbon steel	Stainless steel
	Spring optional	1.4310	1.4310	-
55	Stud	1.4401	1.4401	1.4401
		B8M	B8M	B8M
56	Nut	1.4401	1.4401	1.4401
		8M	8M	8M
57	Ball	1.4401	1.4401	1.4401
		316	316	316
60	Gasket	Graphite / 1.4401	Graphite / 1.4401	Graphite / 1.4401
		Graphite / 316L	Graphite / 316L	Graphite / 316L
61	Ball	1.3541	1.3541	1.4401
		Hardened stainless steel	Hardened stainless steel	316
66	Screw	1.4401	1.4401	1.4401
		B8M	B8M	B8M

Please notice:

- Modifications reserved by LESER.
- LESER can upgrade materials without notice.
- Every part can be replaced by other material acc. to customer specification.

Type 457, 458

LESER

Balanced bellows design

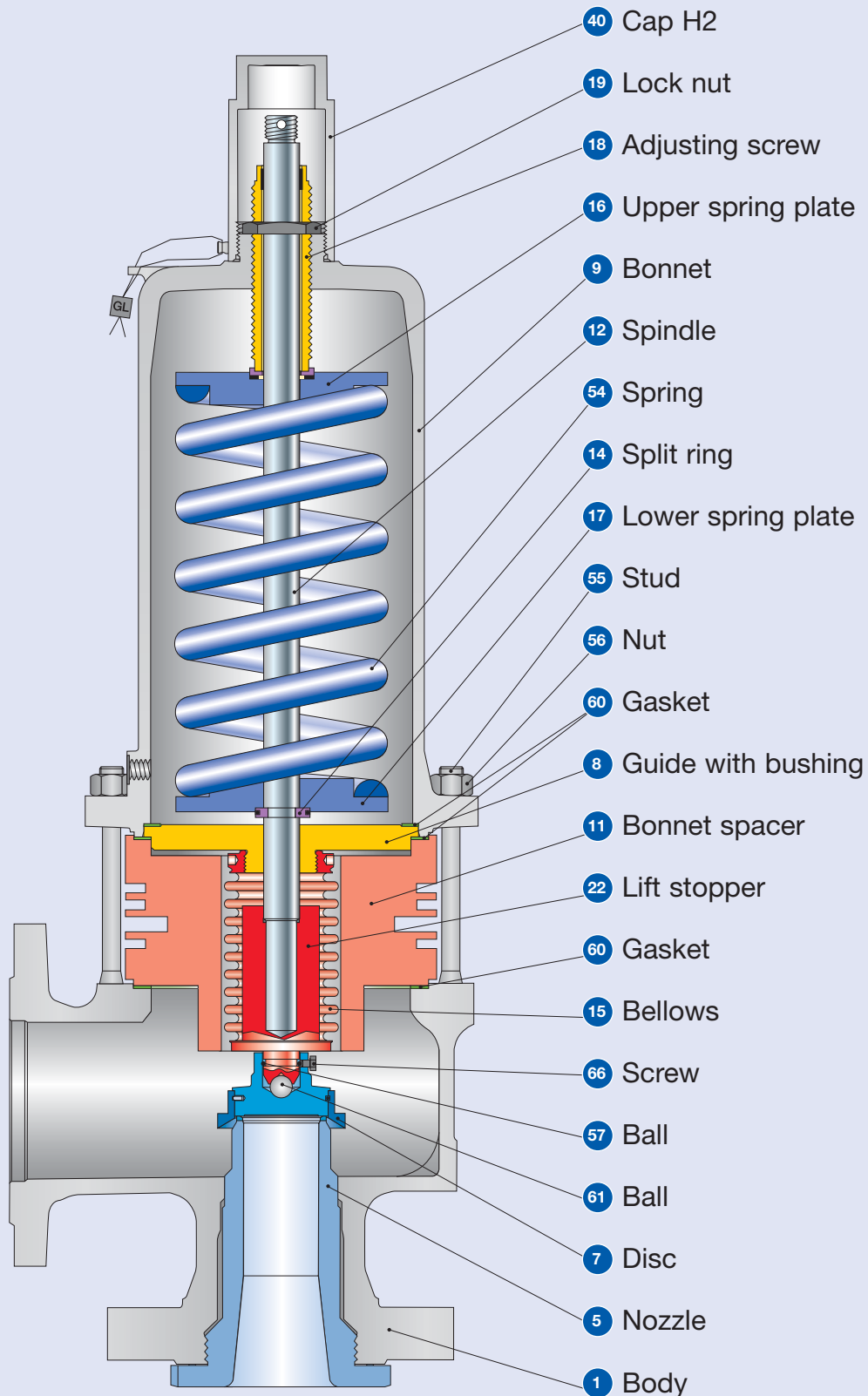

Type 457, 458

Balanced bellows design

Materials				
Item	Component	Type 4572 / 4582	Type 4577 / 4587	Type 4584
1	Body	1.0619	1.7357	1.4581
		SA 216 WCB	SA 217 WC6	SA 351 CF10M
5	Nozzle	1.4404	1.4404 stellited	1.4404
		316L	316L	316L
7	Disc	1.4122	1.4122	1.4404
		Hardened stainless steel	Hardened stainless steel	316L
8	Guide with bushing	1.0501, 0.7040	1.0501, 0.7040	1.4404
		Chrome or carbon steel	Chrome or carbon steel	316L
		1.4104 tenifer Chrome steel	1.4104 tenifer Chrome steel	-
9	Bonnet	0.7043 or 1.0619	0.7043 or 1.0619	1.4408, 1.4404, 1.4571
		Ductile Gr. 60-40-18 or SA 216 WCB	Ductile Gr. 60-40-18 or SA 216 WCB	SA 351 CF8M, SA 479 316L, 316Ti
11	Bonnet spacer	1.0460 Carbon steel	1.0460 Carbon steel	1.4404 316L
12	Spindle	1.4404	1.4404	1.4404
		316L	316L	316L
14	Split ring	1.4104	1.4104	1.4404
		Chrome steel	Chrome steel	316L
15	Bellows	1.4571	1.4571	1.4571
		316Ti	316Ti	316Ti
16 / 17	Spring plate	1.0718	1.0718	1.4404
		Steel	Steel	316L
18	Adjusting screw with bushing	1.4104 PTFE	1.4104 PTFE	1.4404 PTFE
		Chrome steel PTFE	Chrome steel PTFE	316L PTFE
19	Lock nut	1.0718	1.0718	1.4404
		Steel	Steel	316L
22	Lift stopper	1.4404	1.4404	1.4404
		316L	316L	316L
40	Cap H2	1.0718	1.4404	1.4404
		12L13	316L	316L
54	Spring standard	1.1200, 1.8159, 1.7102	1.1200, 1.8159, 1.7102	1.4310
		Carbon steel	Carbon steel	Stainless steel
	Spring optional	1.4310	1.4310	-
55	Stud	1.7709	1.7709	1.4401
		B16	B16	B8M
56	Nut	1.7258	1.7258	1.4401
		7M	7M	8M
57	Ball	1.4401	1.4401	1.4401
		316	316	316
60	Gasket	Graphite / 1.4401	Graphite / 1.4401	Graphite / 1.4401
		Graphite / 316L	Graphite / 316L	Graphite / 316L
61	Ball	1.3541	1.3541	1.4401
		Hardened stainless steel	Hardened stainless steel	316
66	Screw	1.4401	1.4401	1.4401
		B8M	B8M	B8M

Please notice:

- Modifications reserved by LESER.
- LESER can upgrade materials without notice.
- Every part can be replaced by other material acc. to customer specification.

How to order – Numbering system

1

Article Number

1	2	3	4
458	2	611	2

1 Valve Type 457, 458
 Type 458 – with closed bonnet
 Type 457 – with open bonnet

2 Material code

Code	Body material
2	1.0619 (WCB)
4	1.4581 (CF10M)
7	1.7357 (WC6)

3 Valve code
 Identifies valve size and body material, refer to page 09/09.

4

Code	Lifting lever	
	2	screwed cap
3	plain lever	H3
4	packed lever	H4
5	plain lever with open bonnet	H3

4582.6112

Article No.

2

Set Pressure

Please state unit (in gauge)!

Please do not exceed the pressure range defined in the spring charts.

5 bar_g

Set Pressure

3

Connections

Please refer to page 09/16

H47

Connections

4

Options

Type 457, 458

- O-ring-disc

		Option code
CR	"K"	J21
EPDM	"D"	J22
FKM	"L"	J23
FFKM	"C"	J20

- Butt-weld connection **S05**
- Disc 1.4404 / 316L **L44**
- Disc 1.4404 / 316L stellited **J25**
- Stainless steel bellows
 - open bonnet (Type 457) **J68**
 - closed bonnet (Type 458) **J78**
- High temperature equipment **J88**
- High temperature alloy spring **X01**
- Stainless steel spring **X04**
- Adaptor for lift indicator H4 **J39**
- Lift indicator **J93**
- Test gag
 - cap H2 **J70**
 - packed lever H4 **J69**
- Nozzle 1.4404 / 316 L stellited **L62**
- Heating jacket
 - Couplings G 3/8 **H29**
 - G 3/4 **H30**
 - Flanges DN 15 **H31**
 - DN 25 **H32**
 - Spacer **H33**
- Drain hole G 1/4 **J18**
- G 1/2 **J19**
- Free of oil and grease **J85**
- Materials
 - NACE **H01**

Option code applies only if not standard

J22

Options

5

Documentation

Please select requested documentation:

Inspections, tests: **Option Code**
 DIN EN 10204-3.2: TÜV-Nord
 Certificate for test pressure **M33**
 Body material 1.7357/WC6 **H09**

LESER Certificate for Global Application **H03**
 - Inspection certificate 3.1 acc. to DIN EN 10204
 - Declaration of conformity acc. to PED 97/23/EC

Material test certificate:
 DIN EN 10204-3.1

Part	Option code
Body	H01
Nozzle	L59
Bonnet	L30
Cap / ever cover	L31
Disc	L23
Studs	N07
Nuts	N08

H01

L30

Documentation

6

Code and Medium

1 **2**
2 **0**

- 1 Code**
1. ASME Section VIII
 2. CE / VdTUEV
 3. ASME Section VIII + CE / VdTUEV

- 2 Medium**
- .1 Gases
 - .2 Liquids
 - .3 Steam
 - .0 Steam / Gases / Liquids (valid only for CE / VdTUEV)

2.0

Code and Medium

How to order – Article numbers

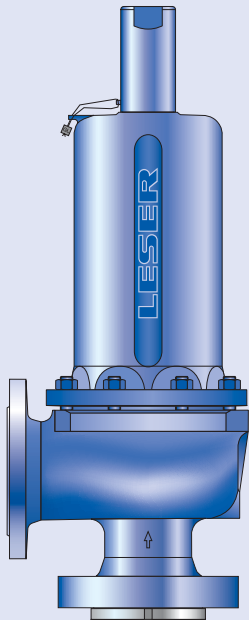

Type 458
Cap H2
Closed bonnet
Conventional design

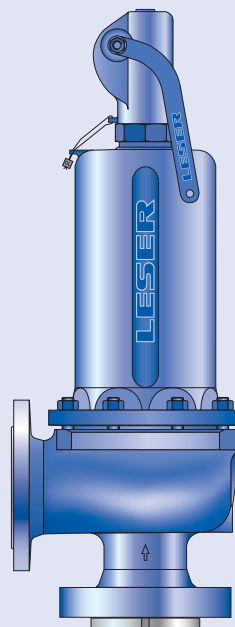

Type 458
Packed lever H4
Closed bonnet
Conventional design

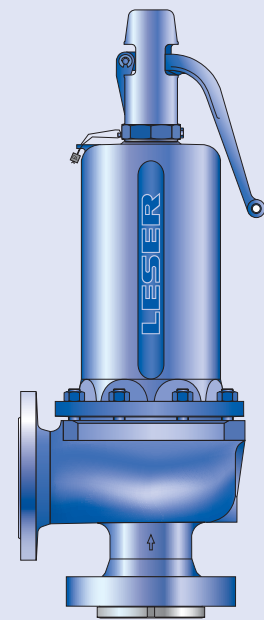

Type 458
Plain lever H3
Closed bonnet
Conventional design

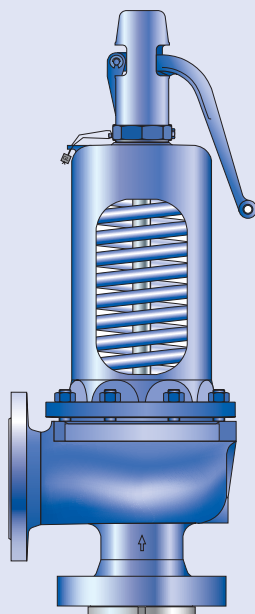

Type 457
Plain lever H3
Open bonnet
Conventional design

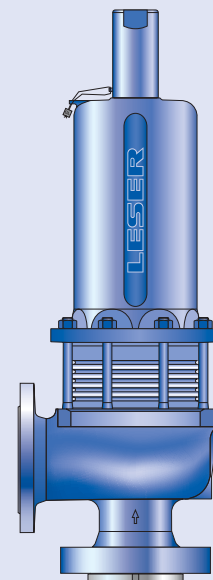

Type 458
Cap H2
Closed bonnet
Balanced bellows design

How to order – Article numbers

Article numbers

DN _{I+O}	25 x 50	25 x 50	50 x 80	50 x 80	80 x 100	80 x 100
Valve size	1" x 2"	1" x 2"	2" x 3"	2" x 3"	3" x 4"	3" x 4"
Actual Orifice diameter d ₀ [mm]	15	20	30	40	50	60
Actual Orifice area A ₀ [mm ²]	177	314	707	1257	1964	2827

Body material: 1.0619 (WCB)

Bonnet closed	H2	Art.-No. 4582.	6102	6112	6122	6132	6142	6152
	H3	Art.-No. 4582.	6103	6113	6123	6133	6143	6153
	H4	Art.-No. 4582.	6104	6114	6124	6134	6144	6154
open	H3	Art.-No. 4572.	6105	6115	6125	6135	6145	6155

Body material: 1.7357 (WC6)

Bonnet closed	H2	Art.-No. 4587.	6302	6312	6322	6332	6342	6352
	H3	Art.-No. 4587.	6303	6313	6323	6333	6343	6353
	H4	Art.-No. 4587.	6304	6314	6324	6334	6344	6354
open	H3	Art.-No. 4577.	6305	6315	6325	6335	6345	6355

Inlet body material: 1.4581 (CF10M)

Bonnet closed	H2	Art.-No. 4584.	6202	6212	6222	6232	6242	6252
	H4	Art.-No. 4584.	6204	6214	6224	6234	6244	6254

Article numbers

DN _{I+O}	100 x 150	100 x 150	100 x 150	100 x 150	150 x 250	
Valve size	4" x 6"	4" x 6"	4" x 6"	4" x 6"	6" x 10"	
Actual Orifice diameter d ₀ [mm]	50	60	74	88	110	
Actual Orifice area A ₀ [mm ²]	1964	2827	4301	6082	9503	

Body material: 1.0619 (WCB)

Bonnet closed	H2	Art.-No. 4582.	6162	6172	6182	6192	4602	
	H3	Art.-No. 4582.	-	-	-	-	-	
	H4	Art.-No. 4582.	6164	6174	6184	6194	4604	
open	H3	Art.-No. 4572.	6165	6175	6185	6195	4605	

Body material: 1.7357 (WC6)

Bonnet closed	H2	Art.-No. 4587.	6362	6372	6382	6392	-	
	H3	Art.-No. 4587.	-	-	-	-	-	
	H4	Art.-No. 4587.	6364	6374	6384	6394	-	
open	H3	Art.-No. 4577.	6365	6375	6385	6395	-	

Body material: 1.4581 (CF10M)

Bonnet closed	H2	Art.-No. 4584.	6262	6272	6282	6292	4732	
	H4	Art.-No. 4584.	6264	6274	6284	6294	4734	

1.4408 (CF8M)

Dimensions and weights

Metric Units

	DN _{I/O}	25 x 50	25 x 50	50 x 80	50 x 80	80 x 100	80 x 100	100 x 150	100 x 150	100 x 150	100 x 150	150 x 250
	Valve size	1" x 2"	1" x 2"	2" x 3"	2" x 3"	3" x 4"	3" x 4"	4" x 6"	4" x 6"	4" x 6"	4" x 6"	6" x 10"
Actual Orifice diameter d ₀ [mm]		15	20	30	40	50	60	50	60	74	88	110
Actual Orifice area A ₀ [mm ²]		177	314	707	1257	1964	2827	1964	2827	4301	6082	9503
Weight [kg]		20	20	45	45	88	88	157	157	157	157	131
	with bellows	22	22	48	48	108	108	188	188	188	188	162
Center to face [mm]	Inlet a	135	135	170	170	190	190	225	225	225	225	300
	Outlet b PN 40	120	120	145	145	180	180	235	235	235	235	225
	Outlet b PN 63	120	120	145	145	205	205	265	265	265	265	–
	Outlet b PN 160	130	130	–	–	–	–	–	–	–	–	–
Measure [mm]	PN 40 – 160 s	41	41	53	53	53	53	60	60	60	60	43
Used to find bolt length for inlet flange	PN 250 s	41	41	53	53	60	60	68	68	68	68	–
	PN 400 s	50	50	–	–	–	–	–	–	–	–	–
Height (H4) [mm]	Standard H max.	506	506	699	699	832	832	1079	1079	1079	1079	1098
	Bellows H max.	541	541	779	779	930	930	1170	1170	1170	1170	1156
Support brackets [mm]	A	140	140	184	184	278	278	364	364	364	364	320
	B	–	–	110	110	160	160	210	210	210	210	185
(drilled only on request)	C	Ø 14	Ø 14	Ø 14	Ø 14	Ø 18	Ø 18	Ø 18	Ø 18	Ø 18	Ø 18	Ø 18
	D	162	162	209	209	240	240	303	303	303	303	392
	E	18	18	18	18	27	27	32	32	32	32	28
Body material: 1.0619 (WCB)												
DIN Flange	Inlet	PN 63 – 250					PN 63 – 160					PN 40
	Outlet	PN 40 – 63					PN 40					PN 16
Body material: 1.7357 (WC6)												
DIN Flange	Inlet	PN 63 – 250					PN 63 – 160					–
	Outlet	PN 40 – 63					PN 40					–
Body material: 1.4581 (CF10M)												1.4408 (CF8M)
DIN Flange	Inlet	PN 63 – 250					PN 63 – 160					PN 40
	Outlet	PN 40 – 63					PN 40					PN 16

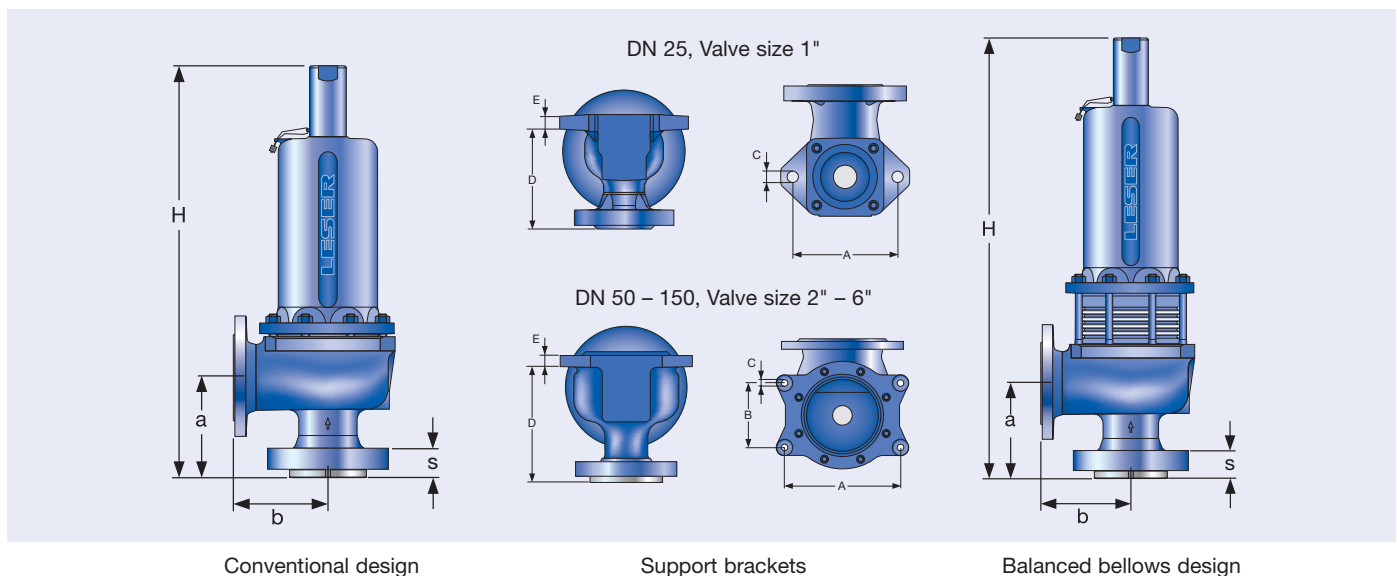

Dimensions and weights

US Units														
		DN _{in} O	25 x 50	25 x 50	50 x 80	50 x 80	80 x 100	80 x 100	100 x 150	100 x 150	100 x 150	100 x 150	150 x 250	
		Valve size	1" x 2"	1" x 2"	2" x 3"	2" x 3"	3" x 4"	3" x 4"	4" x 6"	4" x 6"	4" x 6"	4" x 6"	6" x 10"	
		Actual Orifice diameter d ₀ [inch]	0,59	0,79	1,18	1,57	1,97	2,36	1,97	2,36	2,91	3,46	4,33	
		Actual Orifice area A ₀ [inch ²]	0,274	0,487	1,096	1,948	3,043	4,383	3,043	4,383	6,666	9,427	14,730	
Weight [lbs]			44	44	99	99	194	194	346	346	346	346	289	
	with bellows		49	49	106	106	238	238	415	415	415	415	357	
Center to face [inch]	Inlet a		5 5/16	5 5/16	6 11/16	6 11/16	7 15/32	7 15/32	8 27/32	8 27/32	8 27/32	8 27/32	11 13/16	
	Outlet b	CL150	4 23/32	4 23/32	5 23/32	5 23/32	7 3/32	7 3/32	9 1/4	9 1/4	9 1/4	9 1/4	8 27/32	
	Outlet b	CL300	4 23/32	4 23/32	5 23/32	5 23/32	-	-	-	-	-	-	-	
Measure [inch]	CL150	s	-	-	-	-	-	-	-	-	-	-	1 11/16	
	Used to find bolt length for inlet flange	CL300 – 600	s	1 5/8	1 5/8	2 1/16	2 1/16	2 1/16	2 1/16	2 3/8	2 3/8	2 3/8	2 3/8	-
		CL300 – 1500	s	1 5/8	1 5/8	2 1/16	2 1/16	-	-	-	-	-	-	-
Height (H4) [inch]	Standard H max.		19 29/32	19 29/32	27 17/32	27 17/32	32 3/4	32 3/4	42 1/2	42 1/2	42 1/2	42 1/2	43 7/32	
	Bellows H max.		21 5/16	21 5/16	30 21/32	30 21/32	36 5/8	36 5/8	46 1/16	46 1/16	46 1/16	46 1/16	45 1/2	
Support brackets [mm]	A		5 1/2	5 1/2	7 1/4	7 1/4	10 15/16	10 15/16	41 1/32	41 1/32	41 1/32	41 1/32	12 19/32	
	B		-	-	4 11/32	4 11/32	6 5/16	6 5/16	8 9/32	8 9/32	8 9/32	8 9/32	7 9/32	
	C		Ø 9/16	Ø 9/16	Ø 9/16	Ø 9/16	Ø 23/32	Ø 23/32	Ø 23/32	Ø 23/32	Ø 23/32	Ø 23/32	Ø 23/32	
	D		6 3/8	6 3/8	8 7/32	8 7/32	9 7/16	9 7/16	11 11/32	11 11/32	11 11/32	11 11/32	15 7/16	
	E		23/32	23/32	23/32	23/32	1 1/16	1 1/16	1 1/4	1 1/4	1 1/4	1 1/4	1 3/32	
Body material: 1.0619 (WCB)														
ANSI Flange Class	Inlet		CL300 – 1500				CL300 – 600				CL150			
	Outlet		CL150 – 300				CL150				CL150			
Body material: 1.7357 (WC6)														
ANSI Flange Class	Inlet		CL300 – 1500				CL300 – 600				-			
	Outlet		CL150 – 300				CL150				-			
Body material: 1.4581 (CF10M)													1.4408 (CF8M)	
ANSI Flange Class	Inlet		CL300 – 1500				CL300 – 600				CL150			
	Outlet		CL150 – 300				CL150				CL150			

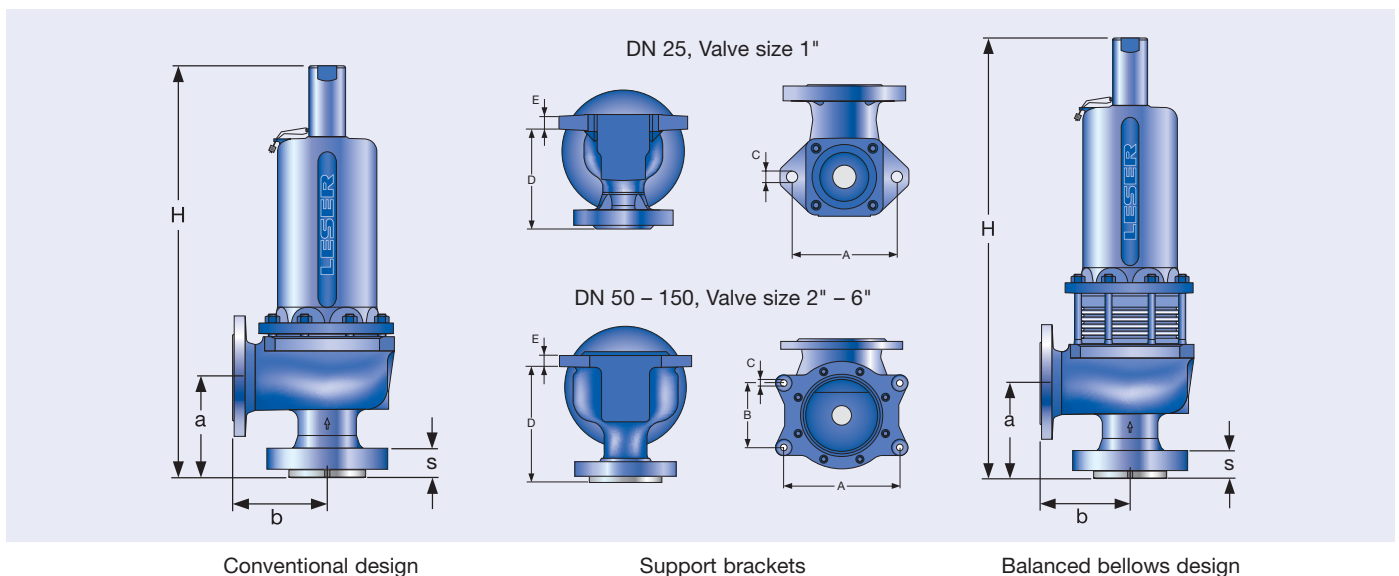

Pressure temperature ratings

Metric Units

		DN _{r,o}	25 x 50	25 x 50	50 x 80	50 x 80	80 x 100	80 x 100	100 x 150	100 x 150	100 x 150	100 x 150	150 x 250	
		Valve size	1" x 2"	1" x 2"	2" x 3"	2" x 3"	3" x 4"	3" x 4"	4" x 6"	4" x 6"	4" x 6"	4" x 6"	6" x 10"	
		Actual Orifice diameter d ₀ [mm]	15	20	30	40	50	60	50	60	74	88	110	
		Actual Orifice area A ₀ [mm ²]	177	314	707	1257	1964	2827	1964	2827	4301	6082	9503	
Body material: 1.0619 (WCB)														
DIN Flange	Inlet		PN 63 – 250				PN 63 – 160						PN 40	
	Outlet		PN 40 – 63				PN 40						PN 16	
Minimum set pressure	p [bar _g]	S/G/L	2,5	2,5	2,5	2,5	2,5	2,5	2,5	2,5	2,5	2,5	2,5	
Min. set pressure¹⁾ standard bellows	p [bar _g]	S/G/L	13,5	13,5	20	2,5	10	10	10	6	5	5	5	
Min. set pressure low press. bellows	p [bar _g]	S/G/L					on request							
Maximum set pressure	p [bar _g]	S/G/L	300	180	125	98	130	77	43	46	53	34	18	
Max. set pressure with special spring	p [bar _g]	S/G/L	300	180	210	114,5	160	77	160	160	77	53	40	
Temperature acc. to DIN EN	min. [°C]								-85					
	max. [°C]								+450					
Temperature acc. to ASME	min. [°C]								-29					
	max. [°C]								+427					

Body material: 1.7357 (WCB)														
DIN Flange	Inlet		PN 63 – 250				PN 63 – 160						–	
	Outlet		PN 40 – 63				PN 40						–	
Minimum set pressure	p [bar _g]	S/G/L	2,5	2,5	2,5	2,5	2,5	2,5	2,5	2,5	2,5	2,5	–	
Min. set pressure¹⁾ standard bellows	p [bar _g]	S/G/L	13,5	13,5	20	2,5	10	10	10	6	5	5	–	
Min. set pressure low press. bellows	p [bar _g]	S/G/L					on request						–	
Maximum set pressure	p [bar _g]	S/G/L	300	180	125	98	130	77	43	46	53	34	–	
Max. set pressure with special spring	p [bar _g]	S/G/L	300	180	210	114,5	160	77	160	160	77	53	–	
Temperature acc. to DIN EN	min. [°C]								-85					
	max. [°C]								+550					
Temperature acc. to ASME	min. [°C]								-29					
	max. [°C]								+538					

Body material: 1.4581 (CF10M)													1.4408 (CF8M)	
DIN Flange	Inlet		PN 63 – 250				PN 63 – 160						PN 40	
	Outlet		PN 40 – 63				PN 40						PN 16	
Minimum set pressure	p [bar _g]	S/G/L	2,5	2,5	2,5	2,5	2,5	2,5	2,5	2,5	2,5	2,5	2,5	
Min. set pressure¹⁾ standard bellows	p [bar _g]	S/G/L	13,5	13,5	20	2,5	10	10	10	6	5	5	5	
Min. set pressure low press. bellows	p [bar _g]	S/G/L					on request						–	
Maximum set pressure	p [bar _g]	S/G/L	250	146	82	61	61	35	15,8	11	16,9	0	4,4	
Max. set pressure with special spring	p [bar _g]	S/G/L	250	146	130	65	104	51,5	71	55	49	32	10	
Temperature acc. to DIN EN	min. [°C]								-85					
	max. [°C]								+550					
Temperature acc. to ASME	min. [°C]								-29					
	max. [°C]								+538					

¹⁾ Min. set pressure standard bellows = Max. set pressure low pressure bellows.

Pressure temperature ratings

US Units														
		DN _{ISO}	25 x 50	25 x 50	50 x 80	50 x 80	80 x 100	80 x 100	100 x 150	100 x 150	100 x 150	100 x 150	150 x 250	
		Valve size	1" x 2"	1" x 2"	2" x 3"	2" x 3"	3" x 4"	3" x 4"	4" x 6"	4" x 6"	4" x 6"	4" x 6"	6" x 10"	
		Actual Orifice diameter d ₀ [inch]	0,59	0,79	1,18	1,57	1,97	2,36	1,97	2,36	2,91	3,46	4,33	
		Actual Orifice area A ₀ [inch ²]	0,274	0,487	1,096	1,948	3,043	4,383	3,043	4,383	6,666	9,427	14,730	
Body material: 1.0619 (WCB)														
ANSI Flange Class ¹⁾	Inlet		CL300 – 1500				CL300 – 600				CL150			
	Outlet		CL150 – 300				CL150				CL150			
Minimum set pressure	p [psig]	S/G/L	36	36	36	36	36	36	36	36	36	36	36	
Min. set pressure²⁾ standard bellows	p [psig]	S/G/L	196	196	290	36	145	145	145	87	73	73	73	
Min. set pressure low press. bellows	p [psig]	S/G/L					on request							
Maximum set pressure	p [psig]	S/G/L	4350	2610	1813	1421	1885	1117	624	667	769	493	261	
Max. set pressure with special spring	p [psig]	S/G/L	4350	2610	3045	1660	2320	1117	2320	2320	1117	769	580	
Temperature	min. [°F]								-121					
acc. to DIN EN	max. [°F]								+842					
Temperature	min. [°F]								-20					
acc. to ASME	max. [°F]								+800					
Body material: 1.7357 (WCB)														
ANSI Flange Class ¹⁾	Inlet		CL300 – 1500				CL300 – 600				-			
	Outlet		CL150 – 300				CL150				-			
Minimum set pressure	p [psig]	S/G/L	36	36	36	36	36	36	36	36	36	36	-	
Min. set pressure²⁾ standard bellows	p [psig]	S/G/L	196	196	290	36	145	145	145	87	73	73	-	
Min. set pressure low press. bellows	p [psig]	S/G/L					on request						-	
Maximum set pressure	p [psig]	S/G/L	4350	2610	1813	1421	1885	1117	624	667	769	493	-	
Max. set pressure with special spring	p [psig]	S/G/L	4350	2610	3045	1660	2320	1117	2320	2320	1117	769	-	
Temperature	min. [°F]								-121					
acc. to DIN EN	max. [°F]								+1022					
Temperature	min. [°F]								-20					
acc. to ASME	max. [°F]								+1000					
Body material: 1.4581 (CF10M)														
ANSI Flange Class ¹⁾	Inlet		CL300 – 1500				CL300 – 600				CL150			
	Outlet		CL150 – 300				CL150				CL150			
Minimum set pressure	p [psig]	S/G/L	36	36	36	36	36	36	36	36	36	36	36	
Min. set pressure²⁾ standard bellows	p [psig]	S/G/L	196	196	290	36	145	145	145	87	73	73	73	
Min. set pressure low press. bellows	p [psig]	S/G/L					on request						-	
Maximum set pressure	p [psig]	S/G/L	3625	2117	1189	885	885	508	229	160	245	0	64	
Max. set pressure with special spring	p [psig]	S/G/L	3625	2117	1885	943	1508	747	1030	798	711	464	145	
Temperature	min. [°F]								-121					
acc. to DIN EN	max. [°F]								+1022					
Temperature	min. [°F]								-20					
acc. to ASME	max. [°F]								+1000					

¹⁾ For flange rating class 150 the pressure temperature ratings according to ASME ANSI B 16.34 apply

²⁾ Min. set pressure standard bellows = Max. set pressure low pressure bellows.

Flange drillings

Flange drillings		DN _{r,o}	25 x 50	25 x 50	50 x 80	50 x 80	80 x 100	80 x 100	100 x 150	100 x 150	100 x 150	100 x 150	150 x 250	
		Valve size	1" x 2"	1" x 2"	2" x 3"	2" x 3"	3" x 4"	3" x 4"	4" x 6"	4" x 6"	4" x 6"	4" x 6"	6" x 10"	
		Actual Orifice diameter d ₀ [mm]	15	20	30	40	50	60	50	60	74	88	110	
		Actual Orifice area A ₀ [mm ²]	177	314	707	1257	1964	2827	1694	2827	4301	6082	9503	
Body material: 1.0619 (WCB), 1.7357 (WC6), 1.4581 (CF10M), 1.4408 (CF8M)														
Inlet	DIN EN 1092	PN 16	H47	H47	H47	H47	H47	H47	-	-	-	-	-	
		PN 25	H47	H47	H47	H47	H47	H47	H47	H47	H47	H47	*	
		PN 40	H47	H47	H47	H47	H47	H47	H47	H47	H47	H47	*	
		PN 63	*	*	H10	H10	H10	H10	H10	H10	H10	H10	S01	
		PN 100	*	*	*	*	*	*	*	*	*	*	*	-
		PN 160	*	*	*	*	*	*	*	*	*	*	*	-
		PN 250	H12	H12	H12	H12	S01	S01	S01	S01	S01	S01	S01	-
		PN 320	S01	S01	S01	S01	S01	S01	S01	S01	S01	S01	S01	-
	PN 400	S01	S01	S01	S01	S01	S01	S01	S01	S01	S01	S01	-	
	ASME B16.5	CL150	-	-	-	-	-	-	-	-	-	-	-	H64
		CL300	H65	H65	H65	H65	H65	H65	H65	H65	H65	H65	H65	-
		CL600	H67	H67	H67	H67	H67	H67	H67	H67	H67	H67	H67	-
		CL900	H69	H69	H69	H69	S01	S01	S01	S01	S01	S01	S01	-
		CL1500	H69	H69	H69	H69	S01	S01	S01	S01	S01	S01	S01	-
CL2500		S01	S01	S01	S01	S01	S01	S01	S01	S01	S01	S01	-	
Outlet	DIN EN 1092	PN 10	*	*	*	*	H51	H51	H51	H51	H51	H51	H50	
		PN 16	*	*	*	*	H51	H51	H51	H51	H51	H51	*	
		PN 25	*	*	*	*	*	*	*	*	*	*	-	
		PN 40	*	*	*	*	*	*	*	*	*	*	-	
	PN 63	H16	H16	H16	H16	S01	S01	S01	S01	S01	S01	S01	-	
	ASME B16.5	CL150	H79	H79	H79	H79	H79	H79	H79	H79	H79	H79	H79	H79
		CL300	H80	H80	H80	H80	S01	S01	S01	S01	S01	S01	S01	-

Flange facings

Flange facings													
Indication	Standard	Inlet		Outlet		Remark							
General													
Flange undrilled	–	H38		H39									
Linde-V-Nut, Form V48	Linde Standard 420-08	J07		J08		Groove: Rz 16							
Linde-V-Nut, Form V48A	LWN 313.36	J05		J06		Groove: Rz 4, e.g. with hydrogen							
Lens seal form L (without sealing lens)	DIN 2696 LWN 313.35	J11		J12									
Acc. to DIN EN													
Flange facing		Inlet		Outlet		Remark							
DIN EN 1092 (new)		DIN 2526 (old)		PN 10 – PN 40	PN 63 – PN 400	PN 10 – PN 40	PN 63	Rz-data according to DIN EN 1092 in µm					
see also LWN 313.40)													
Raised face	Type B1	Type C		*	–	*	–	Facing: Rz = 12,5 – 50					
	Type B2	Type D											
	Type B2	Type E		–	*	L38	*	Facing: Rz = 3,2 – 12,5					
Tongue face C ¹⁾		Tongue face F		L56		H92		Steel flanges only					
Groove face D ¹⁾		Groove face N		L55		H91							
Male face E		Male face V13		I90		H98							
Female face F		Female face R13		I91		H99							
O-ring male face G		Male face V14		I93		J02							
O-ring female face H		Female face R14		I92		J04							
Acc. to ASME B16.5													
Body material	Inlet	Outlet	Smooth finish ²⁾		Serrated finish		RTJ-groove						
			Inlet	Outlet	Inlet	Outlet	Inlet					Outlet	
			Option code	Option code	CL300	CL600	CL900	CL1500	CL2500	CL150	CL300		
all	1"	2"	L52	L53	–	*	L58	L58	L58	L58	L58	H63	H63
	2"	3"	L52	L53	–	*	L58	L58	L58	L58	L58	H63	H63
	3"	4"	L52	L53	–	*	L58	L58	L58	L58	L58	–	H63
	4"	6"	L52	L53	–	*	L58	L58	L58	L58	–	–	H63

¹⁾ According to DIN EN 1092 groove depths and tongue heights increased compared to the formerly valid DIN (refer to LWN 313.40).
LESER manufactures the groove at flanged valves by milling. If a customer demands a turned surface in the soil of the groove according to DIN 2512 and/or DIN EN 1092-1 an additional option code is necessary: „S01: bottom of the groove drilled“. Groove and tongue for PN160 flanges refer to DIN 2512/LWN 313.32.
²⁾ Smooth finish is not defined in the effective standards. For LESER's definition for smooth finish see page 00/07.

For signs and symbols refer to page 00/07

Note: Flange drillings and facings meet always the requirements of mentioned flange standards. Flange thickness and outer diameter may vary from flange standard.

Order information – Spare parts

Spare parts							
	DN _{fl,o}	25 x 50	25 x 50	50 x 80	50 x 80	80 x 100	80 x 100
	Valve size	1" x 2"	1" x 2"	2" x 3"	2" x 3"	3" x 4"	3" x 4"
	Actual Orifice diameter d ₀ [mm]	15	20	30	40	50	60
	Actual Orifice area A ₀ [mm ²]	177	314	707	1257	1964	2827
Disc (Item 7): Metal to metal seat				Material-No. / Art.-No.			
Disc	1.4122	200.0139.9000	200.0239.9000	200.0339.9000	200.0439.9000	200.0539.9000	200.0639.9000
detachable lifting aid	1.4404	200.0169.9000	200.0269.9000	200.0369.9000	200.0469.9000	200.0569.9000	200.0669.9000
Disc (Item 7): Soft seal				Material-No. / Art.-No.			
Disc	CR	"K"	–	200.1149.9053	200.1249.9053	200.1349.9053	200.1449.9053
	EPDM	"D"	–	200.1149.9043	200.1249.9043	200.1349.9043	200.1449.9043
	FKM	"L"	–	200.1149.9073	200.1249.9073	200.1349.9073	200.1449.9073
	FFKM	"C"	–	200.1149.9093	200.1249.9093	200.1349.9093	200.1449.9093
Disc (Item 7.4): Soft seal				Material-No. / Art.-No.			
O-ring	CR	"K"	–	502.0154.3553	502.0247.5353	502.0342.5353	502.0438.5353
	EPDM	"D"	–	502.0154.3543	502.0247.5343	502.0342.5343	502.0438.5343
	FKM	"L"	–	502.0154.3573	502.0247.5373	502.0342.5373	502.0438.5373
	FFKM	"C"	–	502.0154.3593	502.0247.5393	502.0342.5393	502.0438.5393
Bellows (Item 15)				Material-No. / Art.-No.			
Standard bellows		400.5749.0000	400.5749.0000	400.5849.0000	400.5949.0000	400.6049.0000	400.6149.0000
Conversion kit standard¹⁾		on request	on request	on request	on request	on request	on request
Low pressure bellows		on request	on request	on request	on request	on request	on request
Conversion kit low pressure¹⁾		on request	on request	on request	on request	on request	on request
Gasket – body / bonnet (Item 60)				Material-No. / Art.-No.			
Gasket	Graphite + 1.4401	500.1007.0000	500.1007.0000	500.1607.0000	500.1607.0000	500.2107.0000	500.2107.0000
Option code L68	Gylon (filled PTFE)	500.1005.0000	500.1005.0000	500.1605.0000	500.1605.0000	500.2105.0000	500.2105.0000
Ball (Item 61)				Material-No. / Art.-No.			
Ball	Ball Ø [mm]	9	9	12	12	15	15
	1.4401	510.0204.0000	510.0204.0000	510.0304.0000	510.0304.0000	510.0404.0000	510.0404.0000
Split ring (Item 14)				Material-No. / Art.-No.			
Split ring	Spindle Ø [mm]	16	16	20	20	24	24
	1.4404	251.0249.0000	251.0249.0000	251.0349.0000	251.0349.0000	251.0449.0000	251.0449.0000
Ball (Item 57)				Material-No. / Art.-No.			
Ball (15 pieces)	Ball Ø [mm]	3	3	3	3	3	3
	1.4310	510.0604.0000	510.0604.0000	510.0604.0000	510.0604.0000	510.0604.0000	510.0604.0000
Screw (Item 66)				Material-No. / Art.-No.			
Screw	1.4401	451.0114.0000	451.0114.0000	451.0114.0000	451.0114.0000	451.0114.0000	451.0114.0000

¹⁾ For pressure range see page 09/12 – 09/13.
A conversion kit contains the following components:

Item	Component	No.
8	Guide	1
11	Bonnet spacer	1
12	Spindle	1
15	Bellows	1
55	Stud	4, 8 depends on valve size
60	Gasket	2, 3 depends on valve size
	Installation instruction LWN 037.05	1

Refer to page 09/04

Order information – Spare parts

Spare parts							
	DN _{H₂O}	100 x 150	100 x 150	100 x 150	100 x 150	150 x 250	
	Valve size	4" x 6"	4" x 6"	4" x 6"	4" x 6"	6" x 10"	
	Actual Orifice diameter d ₀ [mm]	50	60	74	88	110	
	Actual Orifice area A ₀ [mm ²]	1964	2827	4301	6082	9503	
Disc (Item 7): Metal to metal seat				Material-No. / Art.-No.			
Disc	1.4122	200.0539.9000	200.0839.9000	200.0939.9000	200.1039.9000	220.0939.9000	
detachable lifting aid	1.4404	200.0569.9000	200.0869.9000	200.0969.9000	200.1069.9000	220.0969.9000	
Disc (Item 7): Soft seal				Material-No. / Art.-No.			
Disc	CR	"K"	200.1449.9053	200.1749.9053	200.1849.9053	200.1949.9053	–
	EPDM	"D"	200.1449.9043	200.1749.9043	200.1849.9043	200.1949.9043	–
	FKM	"L"	200.1449.9073	200.1749.9073	200.1849.9073	200.1949.9073	–
	FFKM	"C"	200.1449.9093	200.1749.9093	200.1849.9093	200.1949.9093	–
Disc (Item 7.4): Soft seal				Material-No. / Art.-No.			
O-ring	CR	"K"	502.0438.5353	502.0533.5353	502.0692.5353	502.0819.5353	–
	EPDM	"D"	502.0438.4353	502.0533.5343	502.0692.5343	502.0819.5343	–
	FKM	"L"	502.0438.7353	502.0533.5373	502.0692.5373	502.0819.5373	–
	FFKM	"C"	502.0438.9353	502.0533.5393	502.0692.5393	502.0819.5393	–
Bellows (Item 15)				Material-No. / Art.-No.			
Standard bellows			400.6049.0000	400.6149.0000	400.6249.0000	400.6249.0000	400.7849.0000
Conversion kit standard¹⁾			on request	on request	on request	on request	on request
Low pressure bellows			on request	on request	on request	on request	on request
Conversion kit low pressure¹⁾			on request	on request	on request	on request	on request
Gasket – body / bonnet (Item 60)				Material-No. / Art.-No.			
Gasket	Graphite + 1.4401		500.2207.0000	500.2207.0000	500.2207.0000	500.2207.0000	500.2207.0000
Option code L68	Gylon (filled PTFE)		500.2205.0000	500.2205.0000	500.2205.0000	500.2205.0000	500.2205.0000
Ball (Item 61)				Material-No. / Art.-No.			
Ball	Ball Ø [mm]	15	15	15	15	15	
	1.4401	510.0404.0000	510.0404.0000	510.0404.0000	510.0404.0000	510.0404.0000	
Split ring (Item 14)				Material-No. / Art.-No.			
Split ring	Spindle Ø [mm]	30	30	30	30	30	
	1.4404	251.0549.0000	251.0549.0000	251.0549.0000	251.0549.0000	251.0549.0000	
Ball (Item 57)				Material-No. / Art.-No.			
Ball (15 pieces)	Ball Ø [mm]	3	3	3	3	3	
	1.4310	510.0604.0000	510.0604.0000	510.0604.0000	510.0604.0000	510.0604.0000	
Screw (Item 66)				Material-No. / Art.-No.			
Screw	1.4401	451.0114.0000	451.0114.0000	451.0114.0000	451.0114.0000	451.0114.0000	

¹⁾ For pressure range see page 09/12 – 09/13.
A conversion kit contains the following components:

Item	Component	No.
8	Guide	1
11	Bonnet spacer	1
12	Spindle	1
15	Bellows	1
55	Stud	8, 12 depends on valve size
60	Gasket	2, 3 depends on valve size
	Installation instruction LWN 037.05	1

Refer to page 09/04

Available Options

For further information refer to "Accessories and Options", page 99/01

Heating jacket

H29, H30: Couplings G 3/8, G 3/4
H31, H32: Flanges DN 15, DN 25

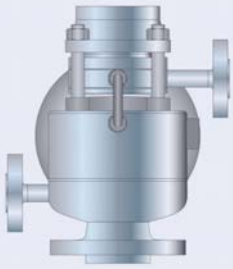

Drain hole

J18: G 1/4
J19: G 1/2

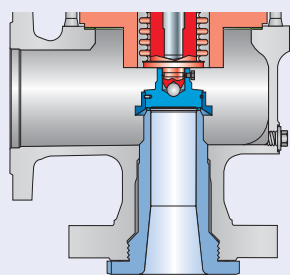

Open bonnet

See Art.-No.

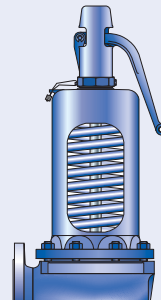

Butt-welded connection

S05

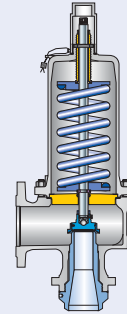

O-ring-disc

J20: FFKM "C"
J21: CR "K"
J22: EPDM "D"
J23: FKM "L"

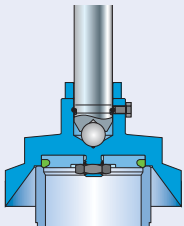

Stainless steel bellows

J68: Open bonnet
J78: Closed bonnet

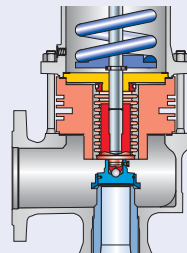

Conversion kit for stainless steel bellows

on request

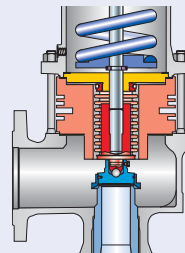

High temperature equipment

J88

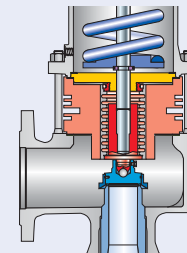

Screwed cap H2

H2

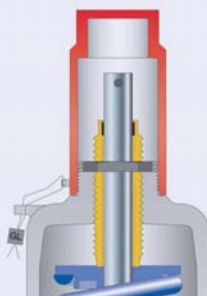

Plain lever H3

H3



Packed lever H4

H4

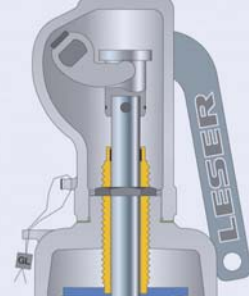

Test gag

J69: H4
J70: H2

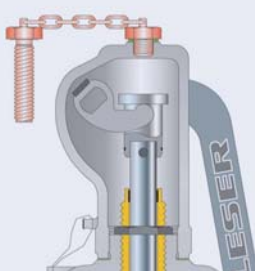

Lift indicator

J39: Adaptor H4
J93: Lift indicator

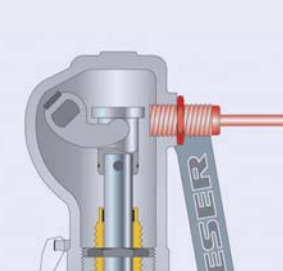

O-ring-damper H2

J65

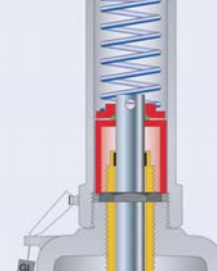

O-ring-damper H4

J66

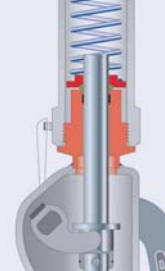

Approvals

Approvals												
	DN _{I+O}	25 x 50	25 x 50	50 x 80	50 x 80	80 x 100	80 x 100	100 x 150	100 x 150	100 x 150	100 x 150	150 x 250
	Valve size	1" x 2"	1" x 2"	2" x 3"	2" x 3"	3" x 4"	3" x 4"	4" x 6"	4" x 6"	4" x 6"	4" x 6"	6" x 10"
	Actual Orifice diameter d ₀ [mm]	15	20	30	40	50	60	50	60	74	88	110
	Actual Orifice area A ₀ [mm ²]	177	314	707	1257	1964	2827	1694	2827	4301	6082	9503
Europe Coefficient of discharge K_{dr}												
DIN EN ISO 4126-1	Approval No.	072020111Z0008/0/12										
	S/G	0,83	0,84	0,84	0,8	0,83	0,75	0,84	0,8	0,8	0,75	0,7
	L	0,63	0,6	0,58	0,54	0,58	0,5	0,6	0,54	0,56	0,49	0,45
Germany Coefficient of discharge α_w												
AD 2000-Merkblatt A2	Approval No.	TÜV SV 934										
	S/G	0,83	0,84	0,84	0,8	0,83	0,75	0,84	0,8	0,8	0,75	0,7
	L	0,63	0,6	0,58	0,54	0,58	0,5	0,6	0,54	0,56	0,49	0,45
United States Coefficient of discharge K												
ASME Sec. VIII	Approval No.	M37066	M37066	M37066	M37066	M37066	M37088	M37066	M37066	M37066	M37088	M37088
	S/G	0,798	0,798	0,798	0,798	0,798	0,754	0,798	0,798	0,798	0,754	0,754
	Approval No.	M37077	M37077	M37077	M37077	M37077	M37099	M37077	M37077	M37077	M37099	M37099
	L	0,572	0,572	0,572	0,572	0,572	0,479	0,572	0,572	0,572	0,479	0,479
Canada Coefficient of discharge K												
Canada: CRN	Approval No.	-										
	S/G	0,798	0,798	0,798	0,798	0,798	0,754	0,798	0,798	0,798	0,754	0,754
	L	0,572	0,572	0,572	0,572	0,572	0,479	0,572	0,572	0,572	0,479	0,479
China Coefficient of discharge α_w												
CSBQTS	Approval No.											
	S/G	0,83	0,84	0,84	0,8	0,83	0,75	0,84	0,8	0,8	0,75	0,7
	L	0,63	0,6	0,58	0,54	0,58	0,5	0,6	0,54	0,56	0,49	0,45
Russia Coefficient of discharge α_w												
GGTN/ GOSGORTECHNADZOR	Approval No.	PPC 00-18458										
GOST R		1989-06										
	S/G	0,83	0,84	0,84	0,8	0,83	0,75	0,84	0,8	0,8	0,75	0,7
	L	0,63	0,6	0,58	0,54	0,58	0,5	0,6	0,54	0,56	0,49	0,45
Belarus Coefficient of discharge α_w												
PROMATOMNADZOR	Approval No.	15-171-2006										
	S/G	0,83	0,84	0,84	0,8	0,83	0,75	0,84	0,8	0,8	0,75	0,7
	L	0,63	0,6	0,58	0,54	0,58	0,5	0,6	0,54	0,56	0,49	0,45
Classification societies												
												on request

Capacities – Steam

Capacities for saturated steam according to AD 2000-Merkblatt A2, based on set pressure plus 10 % overpressure.
 Capacities at 1 bar (14,5 psig) and below are based on 0,1 bar (1,45 psig) overpressure.

Metric Units	AD 2000-Merkblatt A2 [kg/h]										
DN _{ISO}	25 x 50	25 x 50	50 x 80	50 x 80	80 x 100	80 x 100	100 x 150	100 x 150	100 x 150	100 x 150	150 x 250
Valve size	1" x 2"	1" x 2"	2" x 3"	2" x 3"	3" x 4"	3" x 4"	4" x 6"	4" x 6"	4" x 6"	4" x 6"	6" x 10"
Act. Orifice dia. d ₀ [mm]	15	20	30	40	50	60	50	60	74	88	110
Act. Orifice area A ₀ [mm ²]	177	314	707	1257	1964	2827	1694	2827	4301	6082	9503
LEO _{SG} ^{*)} [inch ²]	0,224	0,399	0,897	1,594	2,491	3,389	2,491	3,587	5,456	7,29	11,391
Set pressure [bar]	Capacities [kg/h]										
2,5	305	535	1205	2036	3429	4403	3388	4641	7149	9470	13998
3	352	619	1409	2385	3915	5094	3915	5366	8265	10958	15980
4	439	781	1779	3011	4882	6352	4940	6775	10306	13664	19926
5	526	946	2129	3605	5844	7604	5914	8111	12338	16358	23855
6	612	1102	2479	4197	6803	8853	6885	9443	14363	19043	27771
7	697	1253	2820	4774	7739	10070	7832	10742	16339	21662	31591
8	782	1407	3167	5362	8692	11310	8797	12064	18351	24329	35480
9	868	1562	3513	5949	9643	12548	9760	13385	20360	26992	39364
10	953	1715	3860	6535	10594	13785	10722	14704	22367	29653	43244
12	1124	2023	4552	7707	12494	16257	12645	17341	26378	34972	51000
14	1292	2324	5230	8855	14355	18678	14527	19923	30306	40179	58594
16	1463	2631	5921	10024	16250	21145	16446	22555	34308	45486	66333
18	1633	2939	6612	11195	18149	23615	18367	25189	38316	50799	74081
20	1804	3247	7305	12368	20050	26089	20291	27828	42330	56120	81842
22	1970	3545	7977	13506	21894	28489	22158	30388	46224	61283	89371
24	2142	3854	8671	14681	23799	30967	24085	33031	50245	66614	97145
26	2314	4163	9366	15859	25708	33452	26018	35682	54276	71958	104939
28	2486	4473	10064	17040	27623	35943	27956	38340	58319	77318	112756
30	2659	4784	10764	18225	29544	38443	29900	41006	62374	82695	120596
32	2832	5096	11466	19414	31471	40950	31850	43680	66443	88089	128463
34	2998	5394	12137	20549	33311	43345	33713	46235	70328	93240	135975
36	3172	5707	12842	21743	35247	45863	35671	48921	74414	98657	143875
38	3347	6022	13549	22941	37189	48391	37637	51617	78515	104094	151804
40	3523	6338	14260	24144	39140	50929	39611	54324	82632	109553	159765
50	4411	7937	17858	30235	49014	63777	49605	68029	103480	137192	
60	5306	9546	21479	36366	58952	76709	59663	81823	124462		
70	6236	11221	25246	42745	69294	90166	70129	96177	146296		
80	7174	12907	29042	49171	79711		80671	110634			
90	8160	14682	33035	55932	90670		91763	125846			
100	9156	16473	37065	62756	101733		102959	141201			
120	11326	20378	45850		125844		127361	174666			
140	13773	24781	55758		153039		154882	212410			
160	16604	29873	67215		184485		186707	256056			
180	20171	36291	81656								
200	24970		101082								

*) LEO_{SG} = LESER Effective Orifice steam/gas please refer to page 00/11
 How to use capacity-sheets refer to page 00/09

Capacities – Steam

Capacities for saturated steam according to ASME Section VIII (UV), based on set pressure plus 10% overpressure.
 Capacities at 2,07 bar (30 psig) and below are based on 0,207 bar (3 psig) overpressure.

US Units		ASME Section VIII [lb/h]									
DN _{I+O}	25 x 50	25 x 50	50 x 80	50 x 80	80 x 100	80 x 100	100 x 150	100 x 150	100 x 150	100 x 150	150 x 250
Valve size	1" x 2"	1" x 2"	2" x 3"	2" x 3"	3" x 4"	3" x 4"	4" x 6"	4" x 6"	4" x 6"	4" x 6"	6" x 10"
Act. Orifice dia. d ₀ [inch]	0,59	0,79	1,18	1,57	1,97	2,36	1,97	2,36	2,91	3,46	4,33
Act. Orifice area A ₀ [inch ²]	0,274	0,487	1,096	1,948	3,043	4,383	3,043	4,383	6,666	9,427	14,730
LEO _{S/G} ^{*)} [inch ²]	0,224	0,399	0,897	1,594	2,491	3,389	2,491	3,587	5,456	7,29	11,391
Set pressure [psig]	Capacities [lb/h]										
40	660	1174	2641	4695	7336	9982	7336	10565	16070	21472	33551
50	784	1394	3136	5576	8712	11854	8712	12546	19083	25499	39843
60	908	1614	3632	6456	10088	13726	10088	14527	22097	29526	46134
70	1032	1834	4127	7337	11464	15598	11464	16508	25111	33553	52426
80	1156	2054	4622	8217	12840	17470	12840	18489	28124	37580	58718
90	1279	2275	5118	9098	14216	19342	14216	20471	31138	41606	65010
100	1403	2495	5613	9979	15591	21214	15591	22452	34152	45633	71302
120	1651	2935	6604	11740	18343	24958	18343	26414	40179	53687	83886
140	1899	3375	7594	13501	21095	28702	21095	30377	46206	61740	96469
160	2146	3815	8585	15262	23846	32446	23846	34339	52233	69794	109053
180	2394	4256	9575	17023	26598	36189	26598	38301	58261	77848	121637
200	2641	4696	10566	18784	29350	39933	29350	42264	64288	85901	134221
220	2889	5136	11557	20545	32101	43677	32101	46226	70315	93955	146804
240	3137	5577	12547	22306	34853	47421	34853	50188	76342	102008	159388
260	3384	6017	13538	24067	37605	51165	37605	54151	82370	110062	171972
280	3632	6457	14528	25828	40356	54909	40356	58113	88397	118115	184555
300	3880	6897	15519	27589	43108	58653	43108	62076	94424	126169	197139
320	4127	7338	16510	29350	45860	62397	45860	66038	100451	134223	209723
340	4375	7778	17500	31111	48611	66141	48611	70000	106478	142276	222307
360	4623	8218	18491	32872	51363	69885	51363	73963	112506	150330	234890
380	4870	8658	19481	34633	54115	73629	54115	77925	118533	158383	247474
400	5118	9099	20472	36395	56866	77373	56866	81888	124560	166437	260058
500	6356	11300	25425	45200	70625	96092	70625	101700	154696	206705	322976
600	7594	13501	30378	54005	84383	114812	84383	121512	184833	246973	
700	8833	15703	35331	62810	98141	133531	98141	141324	214969	287241	
800	10071	17904	40284	71616	111900	152251	111900	161136	245105		
900	11309	20105	45237	80421	125658	170970	125658	180948	275241		
1000	12547	22307	50190	89226	139416	189690	139416	200759	305377		
1100	13786	24508	55143	98032	153175	208410	153175	220571	335514		
1200	15024	26709	60096	106837	166933		166933	240383			
1300	16262	28911	65049	115642	180691		180691	260195			
1400	17476	31068	69903	124273	194176		194176	279614			
1500	18829	33473	75314	133892	209206		209206	301256			
2000	26033	46281	104132		289256		289256	416528			
2500	34450	61245	137802								
3000	37312		149250								

^{*)} LEO_{S/G} = LESER Effective Orifice steam/gas please refer to page 00/11
 How to use capacity-sheets refer to page 00/09

Capacities – Air

Capacities for air according to AD 2000-Merkblatt A2, based on set pressure plus 10 % overpressure at 0 °C and 1013 mbar.
 Capacities at 1 bar (14,5 psig) and below are based on 0,1 bar (1,45 psig) overpressure.

Metric Units		AD 2000-Merkblatt A2 [m_n^3/h]									
DN _{I+O}	25 x 50	25 x 50	50 x 80	50 x 80	80 x 100	80 x 100	100 x 150	100 x 150	100 x 150	100 x 150	150 x 250
Valve size	1" x 2"	1" x 2"	2" x 3"	2" x 3"	3" x 4"	3" x 4"	4" x 6"	4" x 6"	4" x 6"	4" x 6"	6" x 10"
Act. Orifice dia. d_o [mm]	15	20	30	40	50	60	50	60	74	88	110
Act. Orifice area A_o [mm ²]	177	314	707	1257	1964	2827	1694	2827	4301	6082	9503
LEO _{S/G} ^{*)} [inch ²]	0,224	0,399	0,897	1,594	2,491	3,389	2,491	3,587	5,456	7,29	11,391
Set pressure [bar]	Capacities [m_n^3/h]										
2,5	371	652	1466	2478	4173	5357	4122	5647	8700	11524	17033
3	430	756	1722	2914	4783	6224	4783	6556	10098	13388	19524
4	540	961	2187	3704	6004	7812	6076	8333	12676	16805	24507
5	650	1170	2632	4457	7225	9401	7312	10027	15253	20222	29490
6	760	1368	3077	5210	8445	10989	8547	11722	17830	23639	34474
7	870	1565	3522	5963	9666	12578	9783	13416	20407	27056	39457
8	980	1763	3967	6716	10887	14166	11018	15111	22985	30473	44440
9	1090	1961	4411	7469	12108	15755	12254	16805	25562	33890	49423
10	1200	2158	4856	8222	13328	17343	13489	18499	28139	37307	54406
12	1419	2554	5746	9728	15770	20520	15960	21888	33294	44141	64372
14	1639	2949	6635	11234	18211	23697	18431	25277	38449	50974	74338
16	1859	3344	7525	12740	20653	26874	20902	28665	43603	57808	84304
18	2079	3740	8414	14246	23094	30051	23373	32054	48758	64642	94270
20	2298	4135	9304	15752	25536	33228	25844	35443	53912	71476	104236
22	2518	4530	10193	17258	27977	36404	28315	38831	59067	78310	114202
24	2738	4926	11083	18764	30419	39581	30785	42220	64221	85144	124168
26	2957	5321	11972	20271	32860	42758	33256	45609	69376	91978	134134
28	3177	5716	12862	21777	35302	45935	35727	48997	74531	98812	144100
30	3397	6112	13751	23283	37744	49112	38198	52386	79685	105645	154066
32	3617	6507	14641	24789	40185	52289	40669	55775	84840	112479	164032
34	3836	6902	15530	26295	42627	55466	43140	59164	89994	119313	173998
36	4056	7298	16420	27801	45068	58643	45611	62552	95149	126147	183964
38	4276	7693	17310	29307	47510	61820	48082	65941	100304	132981	193930
40	4496	8088	18199	30813	49951	64997	50553	69330	105458	139815	203897
50	5594	10065	22647	38344	62159	80881	62907	86273	131231	173984	
60	6693	12042	27094	45874	74366	96766	75262	103217	157004		
70	7792	14019	31542	53404	86574	112650	87617	120160	182777		
80	8890	15995	35990	60935	98781		99971	137104			
90	9989	17972	40437	68465	110989		112326	154047			
100	11088	19949	44885	75996	123196		124681	170991			
120	13285	23902	53780		147611		149390	204877			
140	15482	27856	62676		172026		174099	238764			
160	17680	31809	71571		196442		198808	272651			
180	19877	35763	80466								
200	22074		89362								
220	24272										
240	26469										
260	28667										
280	30864										
300	33061										

^{*)} LEO_{S/G} = LESER Effective Orifice steam/gas please refer to page 00/11
 How to use capacity-sheets refer to page 00/09

Capacities – Air

Capacities for air according to AD 2000-Merkblatt A2, based on set pressure plus 10 % overpressure at 0 °C and 1013 mbar.
Capacities at 1 bar (14,5 psig) and below are based on 0,1 bar (1,45 psig) overpressure.

US Units	ASME Section VIII [S.C.F.M.]										
DN _{I+O}	25 x 50	25 x 50	50 x 80	50 x 80	80 x 100	80 x 100	100 x 150	100 x 150	100 x 150	100 x 150	150 x 250
Valve size	1" x 2"	1" x 2"	2" x 3"	2" x 3"	3" x 4"	3" x 4"	4" x 6"	4" x 6"	4" x 6"	4" x 6"	6" x 10"
Act. Orifice dia. d ₀ [inch]	0,59	0,79	1,18	1,57	1,97	2,36	1,97	2,36	2,91	3,46	4,33
Act. Orifice area A ₀ [inch ²]	0,274	0,487	1,096	1,948	3,043	4,383	3,043	4,383	6,666	9,427	14,730
LEO _{S/G} ^{*)} [inch ²]	0,224	0,399	0,897	1,594	2,491	3,389	2,491	3,587	5,456	7,29	11,391
Set pressure [psig]	Capacities [S.C.F.M.]										
40	235	418	941	1673	2613	3556	2613	3764	5724	7649	11951
50	279	497	1118	1986	3103	4223	3103	4470	6798	9083	14193
60	324	575	1294	2300	3593	4890	3593	5175	7871	10517	16434
70	368	653	1471	2614	4083	5557	4083	5881	8945	11952	18675
80	412	732	1647	2928	4573	6224	4573	6587	10018	13386	20916
90	456	810	1824	3241	5063	6891	5063	7293	11091	14821	23158
100	500	889	2000	3555	5553	7558	5553	7999	12165	16255	25399
120	588	1046	2353	4182	6533	8891	6533	9410	14312	19124	29881
140	677	1202	2706	4810	7513	10225	7513	10822	16459	21993	34364
160	765	1359	3059	5437	8493	11559	8493	12234	18606	24861	38847
180	853	1516	3412	6065	9473	12893	9473	13645	20753	27730	43329
200	941	1673	3765	6692	10454	14227	10454	15057	22900	30599	47812
220	1030	1830	4118	7319	11434	15560	11434	16468	25047	33468	52294
240	1118	1987	4471	7947	12414	16894	12414	17880	27193	36336	56777
260	1206	2144	4824	8574	13394	18228	13394	19292	29340	39205	61259
280	1294	2300	5177	9202	14374	19562	14374	20703	31487	42074	65742
300	1383	2457	5530	9829	15354	20896	15354	22115	33634	44943	70224
320	1471	2614	5883	10456	16334	22229	16334	23527	35781	47811	74707
340	1559	2771	6236	11084	17314	23563	17314	24938	37928	50680	79189
360	1647	2928	6589	11711	18294	24897	18294	26350	40075	53549	83672
380	1736	3085	6942	12338	19274	26231	19274	27762	42222	56418	88154
400	1824	3241	7295	12966	20254	27565	20254	29173	44369	59286	92637
500	2265	4026	9060	16103	25155	34234	25155	36231	55104	73630	115050
600	2706	4810	10825	19240	30055	40903	30055	43290	65838	87974	
700	3147	5594	12590	22377	34955	47572	34955	50348	76573	102318	
800	3589	6378	14355	25514	39855	54241	39855	57406	87307		
900	4030	7163	16120	28651	44756	60910	44756	64464	98042		
1000	4471	7947	17885	31788	49656	67579	49656	71522	108777		
1100	4912	8731	19650	34925	54556	74248	54556	78581	119511		
1200	5354	9515	21415	38062	59457		59457	85639			
1300	5795	10300	23180	41199	64357		64357	92697			
1400	6236	11084	24945	44336	69257		69257	99755			
1500	6677	11868	26709	47473	74158		74158	106813			
2000	8884	15789	35534		98659		98659	142104			
2500	11090	19711	44359								
3000	13296		53184								
3500	15502										
4000	17708										
4350	19253										

*) LEO_{S/G} = LESER Effective Orifice steam/gas please refer to page 00/11
How to use capacity-sheets refer to page 00/09

Capacities – Water

Capacities for water according to AD 2000-Merkblatt A2, based on set pressure plus 10 % overpressure at 20 °C (68 °F).
Capacities at 1 bar (14,5 psig) and below are based on 0,1 bar (1,45 psig) overpressure..

Metric Units	AD 2000-Merkblatt A2 [10 ³ kg/h]										
DN _{ISO}	25 x 50	25 x 50	50 x 80	50 x 80	80 x 100	80 x 100	100 x 150	100 x 150	100 x 150	100 x 150	150 x 250
Valve size	1" x 2"	1" x 2"	2" x 3"	2" x 3"	3" x 4"	3" x 4"	4" x 6"	4" x 6"	4" x 6"	4" x 6"	6" x 10"
Act. Orifice dia. d ₀ [mm]	15	20	30	40	50	60	50	60	74	88	110
Act. Orifice area A ₀ [mm ²]	177	314	707	1257	1964	2827	1694	2827	4301	6082	9503
LEO _L ^{*)} [inch ²]	0,241	0,429	0,964	1,714	2,678	3,230	2,678	3,857	5,866	6,947	10,855
Set pressure [bar]	Capacities [10 ³ kg/h]										
2,5	9,39	15,9	34,6	57,2	96,1	119	99,4	129	203	251	361
3	10,3	17,4	37,9	62,7	105	131	109	141	223	275	395
4	11,9	20,1	43,7	72,4	122	151	126	163	257	318	456
5	13,3	22,5	48,9	80,9	136	169	141	182	287	355	510
6	14,5	24,6	53,6	88,7	149	185	154	200	315	389	559
7	15,7	26,6	57,9	95,8	161	200	166	215	340	421	604
8	16,8	28,4	61,9	102	172	213	178	230	363	450	645
9	17,8	30,2	65,6	109	182	226	189	244	385	477	684
10	18,8	31,8	69,2	114	192	238	199	258	406	503	721
12	20,6	34,8	75,8	125	210	261	218	282	445	551	790
14	22,2	37,6	81,8	135	227	282	235	305	481	595	854
16	23,8	40,2	87,5	145	243	302	251	326	514	636	913
18	25,2	42,7	92,8	154	258	320	267	346	545	675	968
20	26,6	45	97,8	162	272	337	281	364	575	711	1020
22	27,9	47,2	103	170	285	354	295	382	603	746	1070
24	29,1	49,3	107	177	298	369	308	399	629	779	1118
26	30,3	51,3	112	185	310	385	320	415	655	811	1163
28	31,4	53,2	116	192	321	399	333	431	680	841	1207
30	32,5	55,1	120	198	333	413	344	446	704	871	1250
32	33,6	56,9	124	205	344	427	356	461	727	899	1291
34	34,6	58,6	128	211	354	440	366	475	749	927	1330
36	35,6	60,3	131	217	365	452	377	489	771	954	1369
38	36,6	62	135	223	374	465	387	502	792	980	1406
40	37,6	63,6	138	229	384	477	397	515	813	1005	1443
50	42,0	71,1	155	256	430	533	444	576	909	1124	
60	46,0	77,9	169	280	471	584	487	631	995		
70	49,7	84,1	183	303	508	631	526	681	1075		
80	53,1	89,9	196	324	543		562	729			
90	56,3	95,4	207	343	576		596	773			
100	59,4	101	219	362	608		628	814			
120	65,1	110	240		666		688	892			
140	70,3	119	259		719		744	964			
160	75,1	127	277		768		795	1030			
180	79,7	135	293								
200	84,0		309								
220	88,1										
240	92,0										
260	95,8										
280	99,4										
300	103										

*) LEO_L = LESER Effective Orifice liquids please refer to page 00/12
How to use capacity-sheets refer to page 00/09

Capacities – Water

Capacities for water according to ASME Section VIII (UV), based on set pressure plus 10 % overpressure at 21 °C (70 °F).
 Capacities at 2,07 bar (30 psig) and below are based on 0,207 bar (3 psig) overpressure.

US Units		ASME Section VIII [US-G.P.M.]									
DN _{I+O}	25 x 50	25 x 50	50 x 80	50 x 80	80 x 100	80 x 100	100 x 150	100 x 150	100 x 150	100 x 150	150 x 250
Valve size	1" x 2"	1" x 2"	2" x 3"	2" x 3"	3" x 4"	3" x 4"	4" x 6"	4" x 6"	4" x 6"	4" x 6"	6" x 10"
Act. Orifice dia. d ₀ [inch]	0,59	0,79	1,18	1,57	1,97	2,36	1,97	2,36	2,91	3,46	4,33
Act. Orifice area A ₀ [inch ²]	0,274	0,487	1,096	1,948	3,043	4,383	3,043	4,383	6,666	9,427	14,730
LEO _L ^{*)} [inch ²]	0,241	0,429	0,964	1,714	2,678	3,230	2,678	3,857	5,866	6,947	10,855
Set pressure [psig]	Capacities [US-G.P.M.]										
40	39,4	70,1	158	280	438	528	438	631	960	1137	1776
50	44,1	78,4	176	314	490	591	490	706	1073	1271	1986
60	48,3	85,9	193	343	537	647	537	773	1175	1392	2175
70	52,2	92,8	209	371	580	699	580	835	1270	1504	2349
80	55,8	99,2	223	397	620	747	620	892	1357	1607	2511
90	59,2	105	237	421	657	793	657	947	1440	1705	2664
100	62,4	111	249	443	693	836	693	998	1517	1797	2808
120	68,3	121	273	486	759	915	759	1093	1662	1969	3076
140	73,8	131	295	525	820	989	820	1181	1795	2126	3322
160	78,9	140	316	561	876	1057	876	1262	1919	2273	3552
180	83,7	149	335	595	929	1121	929	1339	2036	2411	3767
200	88,2	157	353	627	980	1182	980	1411	2146	2541	3971
220	92,5	164	370	658	1027	1239	1027	1480	2251	2665	4165
240	96,6	172	387	687	1073	1294	1073	1546	2351	2784	4350
260	101	179	402	715	1117	1347	1117	1609	2447	2898	4528
280	104	186	417	742	1159	1398	1159	1670	2539	3007	4699
300	108	192	432	768	1200	1447	1200	1728	2628	3113	4863
320	112	198	446	793	1239	1495	1239	1785	2714	3215	5023
340	115	204	460	818	1277	1541	1277	1840	2798	3314	5178
360	118	210	473	841	1314	1585	1314	1893	2879	3410	5328
380	122	216	486	864	1350	1629	1350	1945	2958	3503	5474
400	125	222	499	887	1385	1671	1385	1995	3035	3594	5616
500	139	248	558	992	1549	1868	1549	2231	3393	4018	6279
600	153	272	611	1086	1697	2047	1697	2444	3717	4402	
700	165	293	660	1173	1833	2211	1833	2640	4015	4755	
800	176	314	706	1254	1959	2363	1959	2822	4292		
900	187	333	748	1330	2078	2507	2078	2993	4552		
1000	197	351	789	1402	2191	2642	2191	3155	4799		
1100	207	368	827	1471	2297	2771	2297	3309	5033		
1200	216	384	864	1536	2400	2400	3456				
1300	225	400	900	1599	2498	2498	3597				
1400	233	415	934	1659	2592	2592	3733				
1500	242	429	966	1717	2683	2683	3864				
2000	279	496	1116	3098	3098	4462					
2500	312	554	1247								
3000	342	1367									
3500	369										
4000	394										
4350	411										

*) LEO_L = LESER Effective Orifice liquids please refer to page 00/12
 How to use capacity-sheets refer to page 00/09

Determination of coefficient of discharge in case of lift restriction or back pressure

- h = Lift [mm]
- d₀ = Flow diameter [mm] of selected safety valve, refer to table article numbers
- h/d₀ = Ratio of lift / flow diameter
- p_{a0} = Back pressure [bar_a]
- p₀ = Set pressure [bar_a]
- p_{a0}/p₀ = Ratio of back pressure / set pressure
- K_{dr} = Coefficient of discharge acc. to DIN EN ISO 4126-1
- α_w = Coefficient of discharge acc. to AD 2000-Merkblatt A2
- K_b = Back pressure correction factor acc. to API 520 topic 3.3

Diagram for evaluation of ratio of lift / flow diameter (h/d₀) in reference to the coefficient of discharge (K_{dr}/α_w)

DN 25, d₀ 15

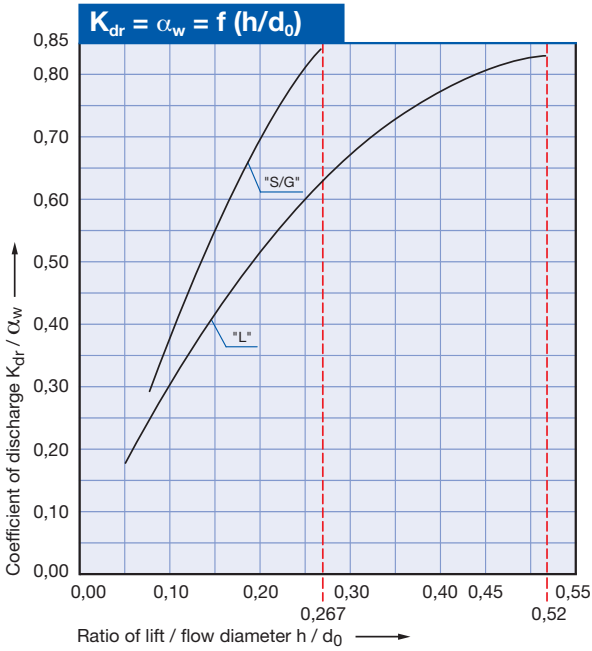

DN 25, d₀ 20

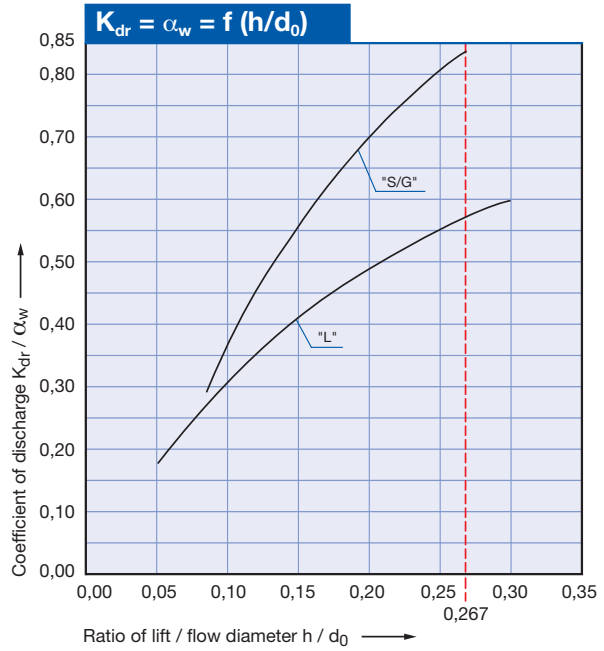
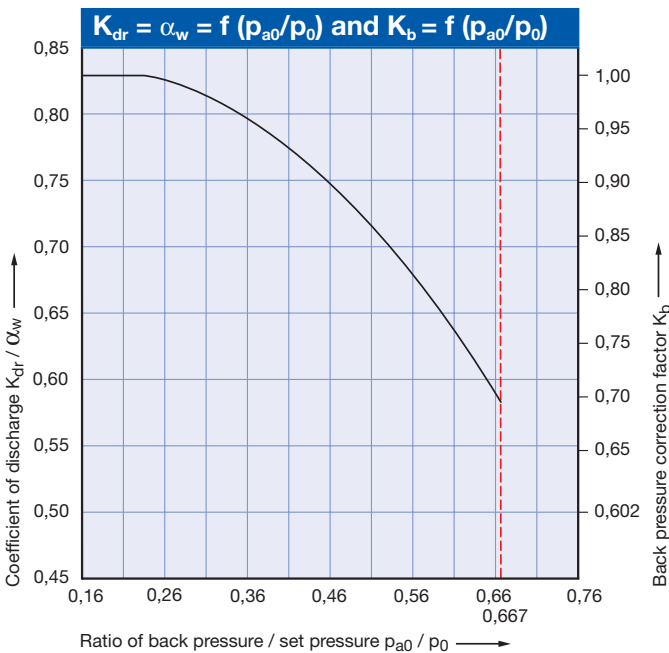
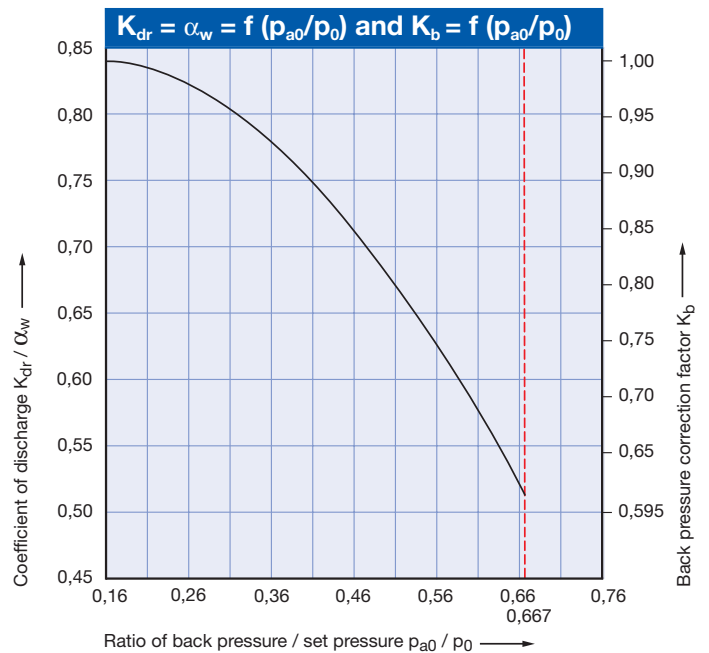

Diagram for evaluation of coefficient of discharge (K_{dr}/α_w) or K_b in reference to the ratio of back pressure / set pressure (p_{a0}/p₀)

DN 25, d₀ 15



DN 25, d₀ 20



Determination of coefficient of discharge in case of lift restriction or back pressure

- h = Lift [mm]
- d₀ = Flow diameter [mm] of selected safety valve, refer to table article numbers
- h/d₀ = Ratio of lift / flow diameter
- p_{a0} = Back pressure [bar_a]
- p₀ = Set pressure [bar_a]
- p_{a0}/p₀ = Ratio of back pressure / set pressure
- K_{dr} = Coefficient of discharge acc. to DIN EN ISO 4126-1
- α_w = Coefficient of discharge acc. to AD 2000-Merkblatt A2
- K_b = Back pressure correction factor acc. to API 520 topic 3.3

Diagram for evaluation of ratio of lift / flow diameter (h/d₀) in reference to the coefficient of discharge (K_{dr}/α_w)

DN 50, d₀ 30

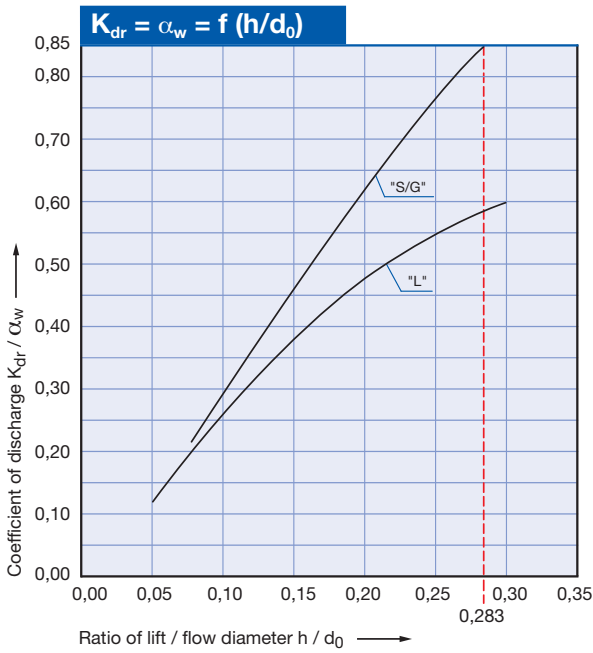

DN 50, d₀ 40

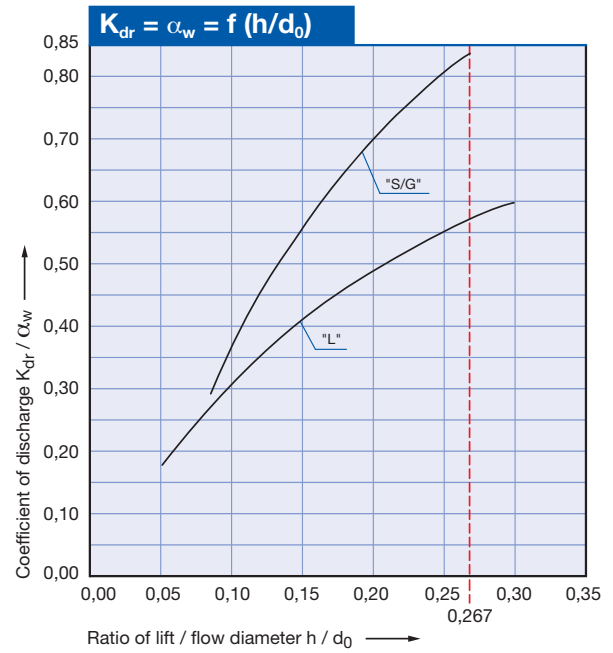
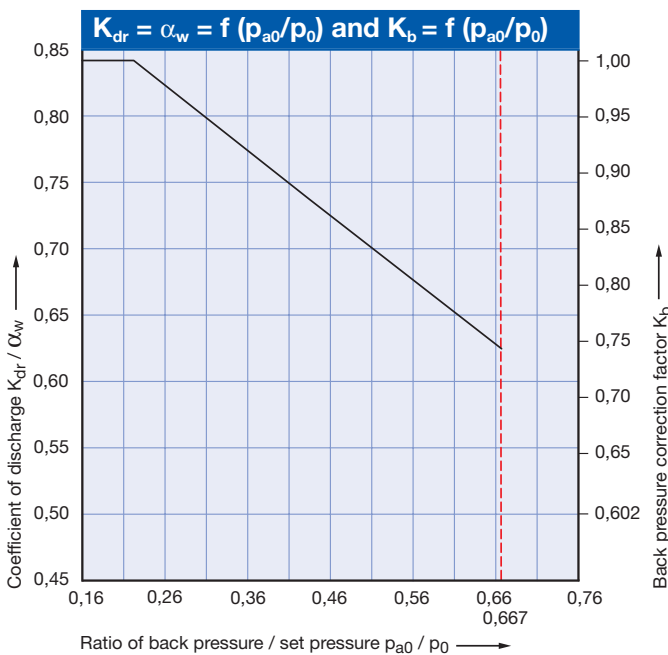
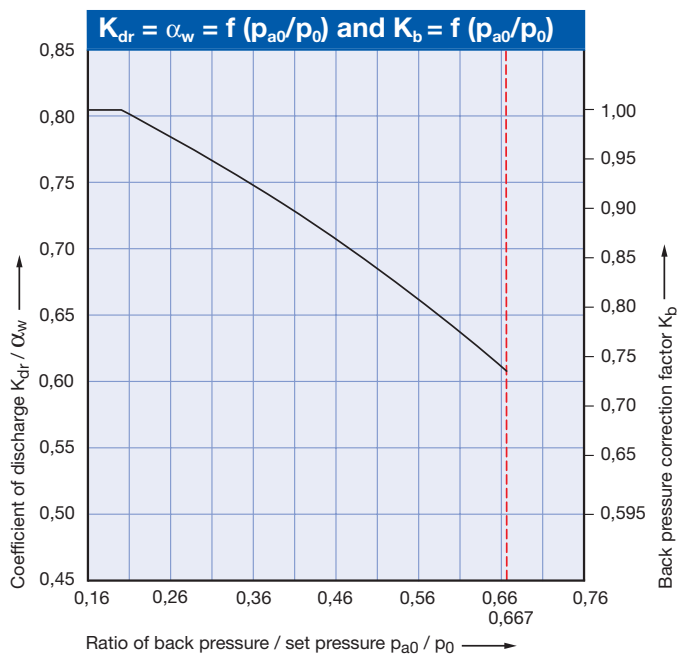

Diagram for evaluation of coefficient of discharge (K_{dr}/α_w) or K_b in reference to the ratio of back pressure / set pressure (p_{a0}/p₀)

DN 50, d₀ 30



DN 50, d₀ 40



Determination of coefficient of discharge in case of lift restriction or back pressure

- h = Lift [mm]
- d₀ = Flow diameter [mm] of selected safety valve, refer to table article numbers
- h/d₀ = Ratio of lift / flow diameter
- p_{a0} = Back pressure [bar_a]
- p₀ = Set pressure [bar_a]
- p_{a0}/p₀ = Ratio of back pressure / set pressure
- K_{dr} = Coefficient of discharge acc. to DIN EN ISO 4126-1
- α_w = Coefficient of discharge acc. to AD 2000-Merkblatt A2
- K_b = Back pressure correction factor acc. to API 520 topic 3.3

Diagram for evaluation of ratio of lift / flow diameter (h/d₀) in reference to the coefficient of discharge (K_{dr}/α_w)

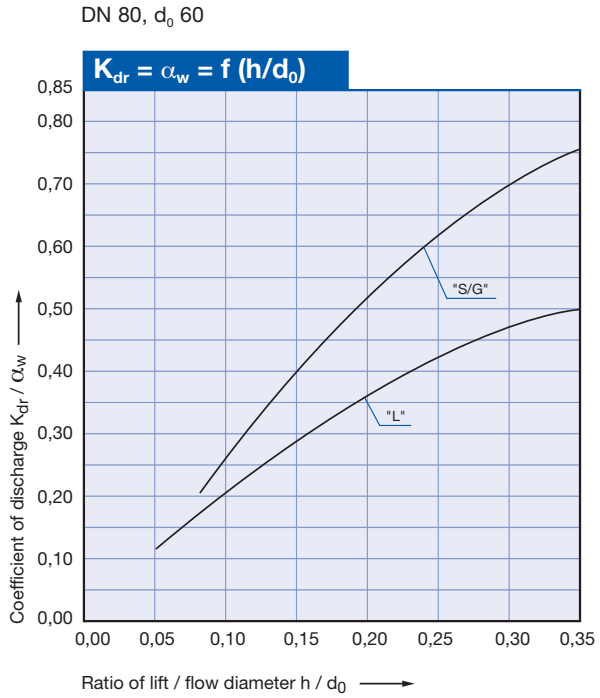
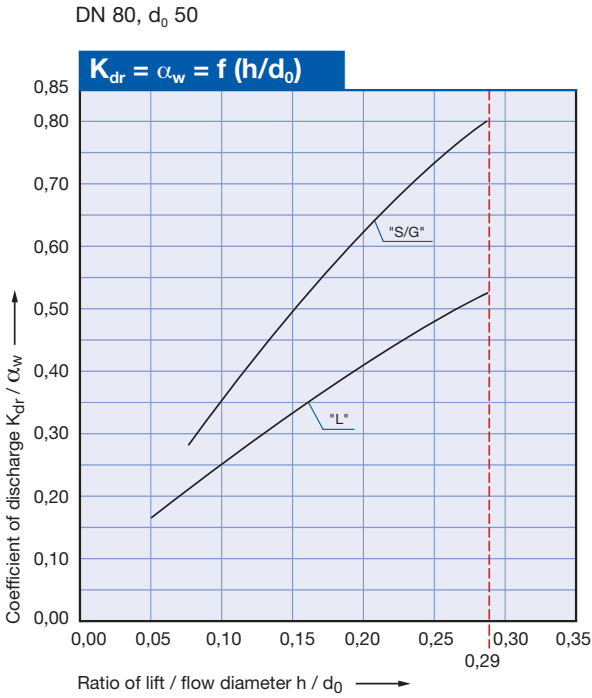
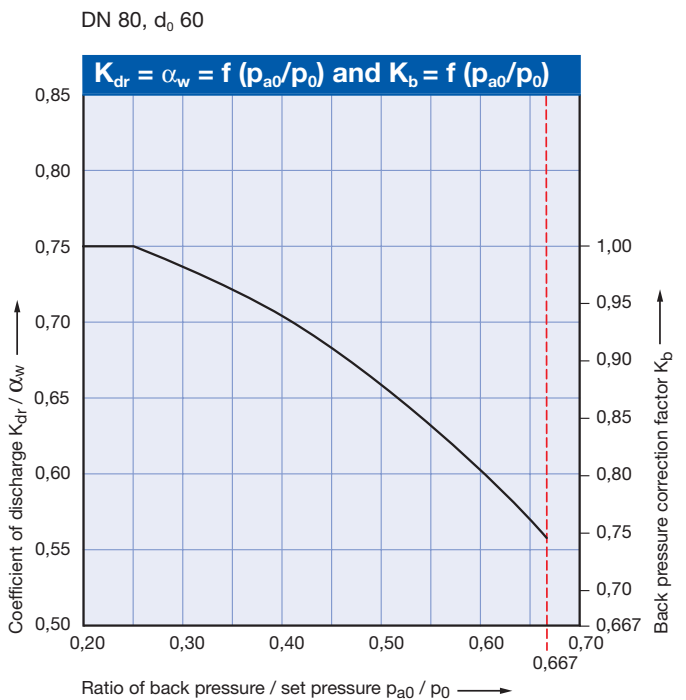
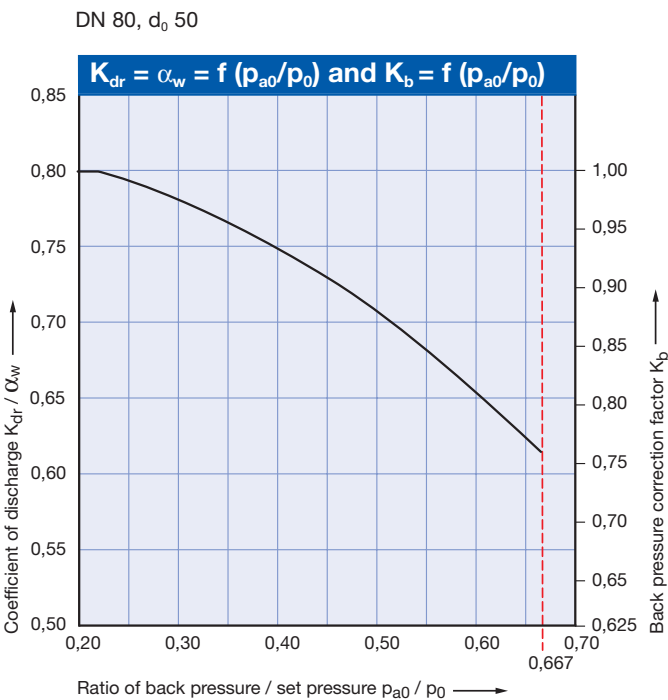

Diagram for evaluation of coefficient of discharge (K_{dr}/α_w) or K_b in reference to the ratio of back pressure / set pressure (p_{a0}/p₀)



How to use please refer to page 00/08

Type 457, 458

Determination of coefficient of discharge in case of lift restriction or back pressure

- h = Lift [mm]
- d₀ = Flow diameter [mm] of selected safety valve, refer to table article numbers
- h/d₀ = Ratio of lift / flow diameter
- p_{a0} = Back pressure [bar_a]
- p₀ = Set pressure [bar_a]
- p_{a0}/p₀ = Ratio of back pressure / set pressure
- K_{dr} = Coefficient of discharge acc. to DIN EN ISO 4126-1
- α_w = Coefficient of discharge acc. to AD 2000-Merkblatt A2
- K_b = Back pressure correction factor acc. to API 520 topic 3.3

Diagram for evaluation of ratio of lift / flow diameter (h/d₀) in reference to the coefficient of discharge (K_{dr}/α_w)

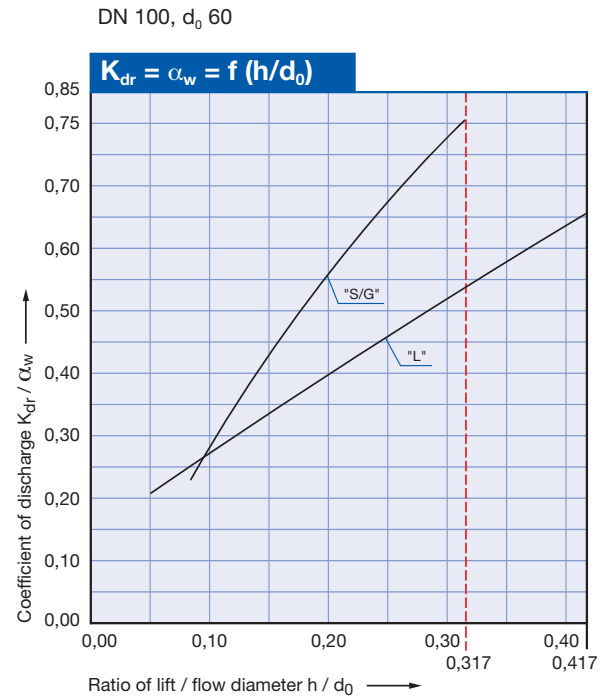
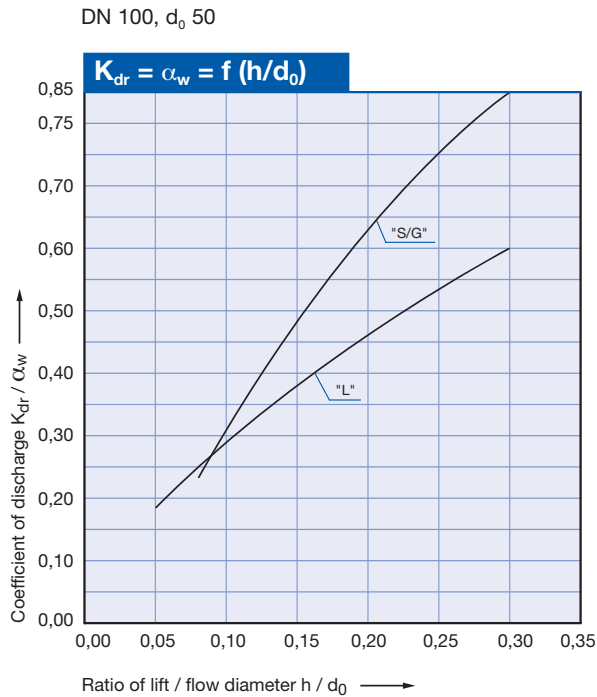
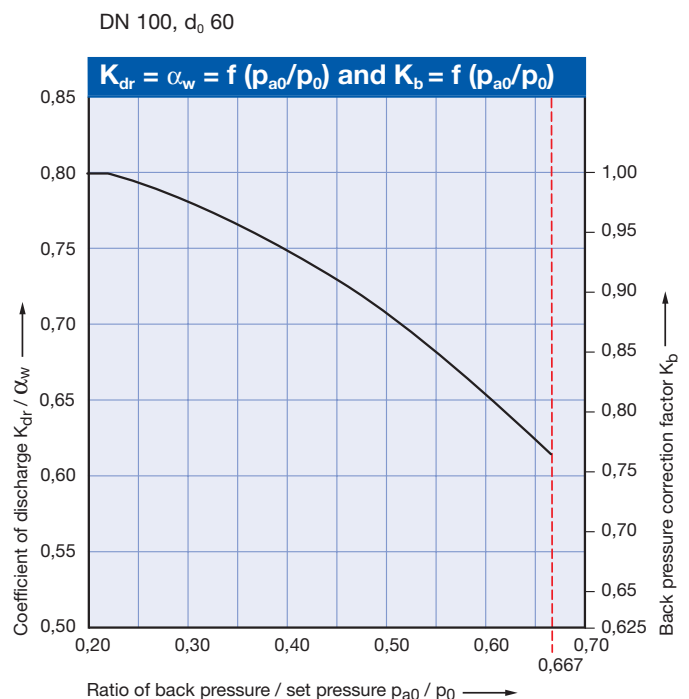
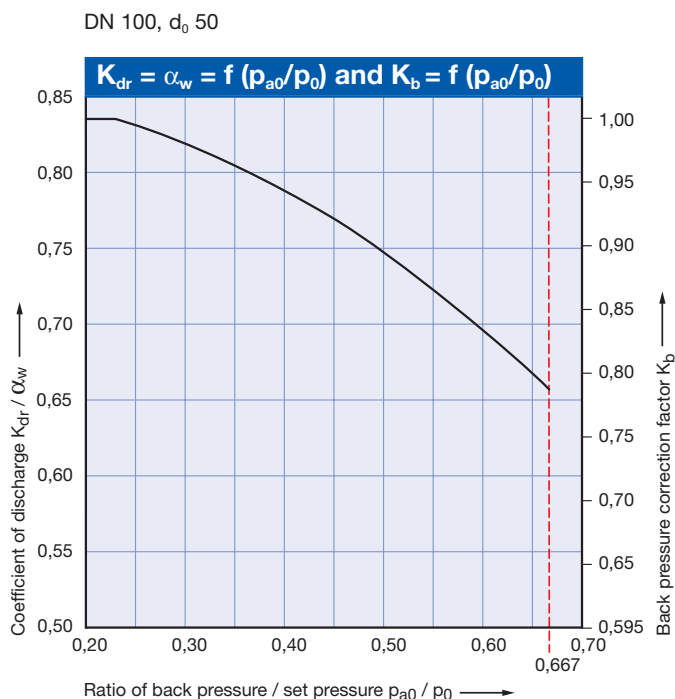

Diagram for evaluation of coefficient of discharge (K_{dr}/α_w) or K_b in reference to the ratio of back pressure / set pressure (p_{a0}/p₀)



Determination of coefficient of discharge in case of lift restriction or back pressure

- h = Lift [mm]
- d₀ = Flow diameter [mm] of selected safety valve, refer to table article numbers
- h/d₀ = Ratio of lift / flow diameter
- p_{a0} = Back pressure [bar_a]
- p₀ = Set pressure [bar_a]
- p_{a0}/p₀ = Ratio of back pressure / set pressure
- K_{dr} = Coefficient of discharge acc. to DIN EN ISO 4126-1
- α_w = Coefficient of discharge acc. to AD 2000-Merkblatt A2
- K_b = Back pressure correction factor acc. to API 520 topic 3.3

Diagram for evaluation of ratio of lift / flow diameter (h/d₀) in reference to the coefficient of discharge (K_{dr}/α_w)

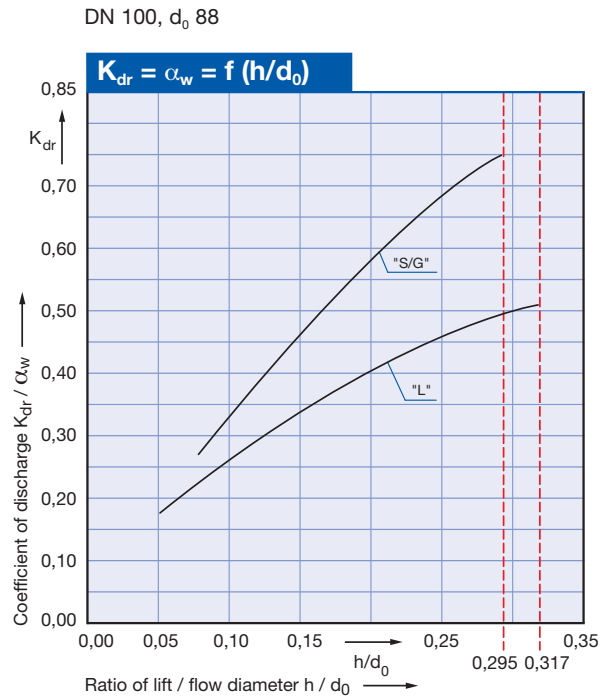
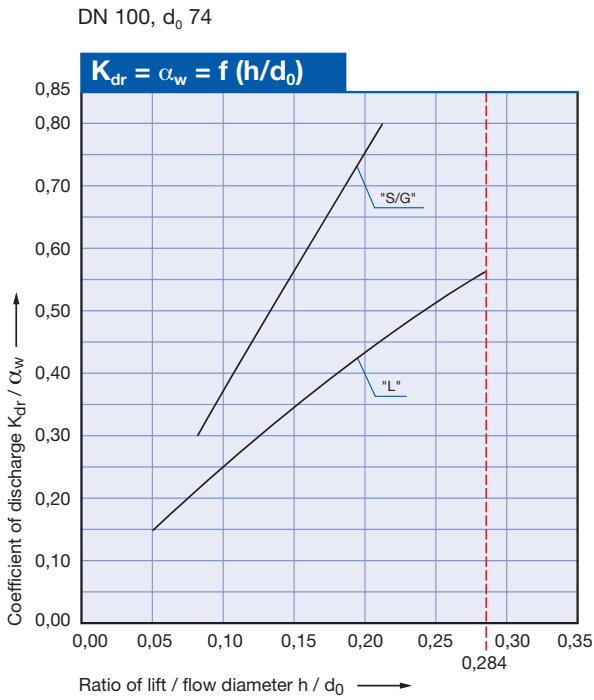
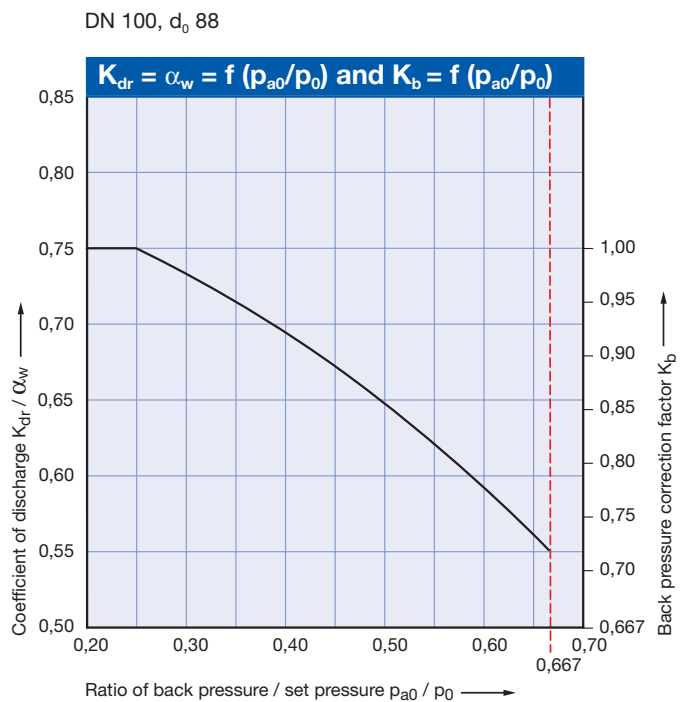
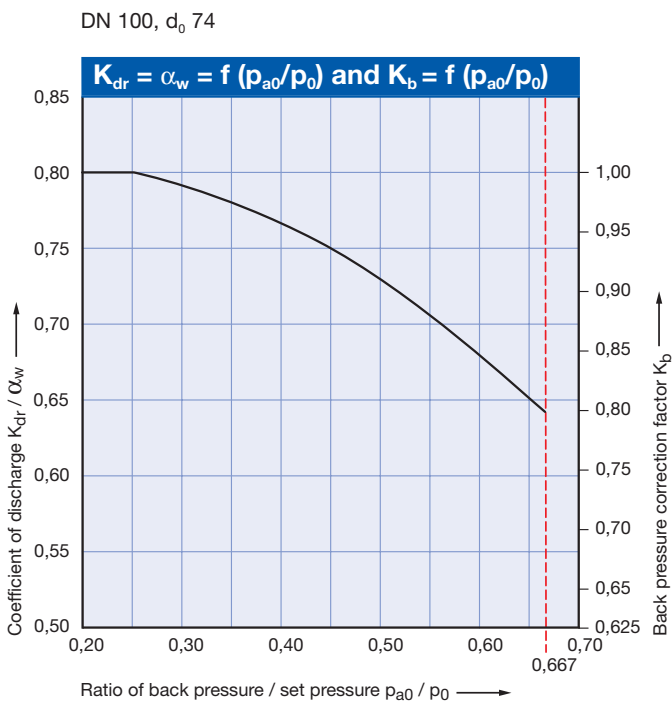

Diagram for evaluation of coefficient of discharge (K_{dr}/α_w) or K_b in reference to the ratio of back pressure / set pressure (p_{a0}/p₀)



How to use please refer to page 00/08

Determination of coefficient of discharge in case of lift restriction or back pressure

- h = Lift [mm]
- d₀ = Flow diameter [mm] of selected safety valve, refer to table article numbers
- h/d₀ = Ratio of lift / flow diameter
- p_{a0} = Back pressure [bar.]
- p₀ = Set pressure [bar.]
- p_{a0}/p₀ = Ratio of back pressure / set pressure
- K_{dr} = Coefficient of discharge acc. to DIN EN ISO 4126-1
- α_w = Coefficient of discharge acc. to AD 2000-Merkblatt A2
- K_b = Back pressure correction factor acc. to API 520 topic 3.3

Diagram for evaluation of ratio of lift / flow diameter (h/d₀) in reference to the coefficient of discharge (K_{dr}/α_w)

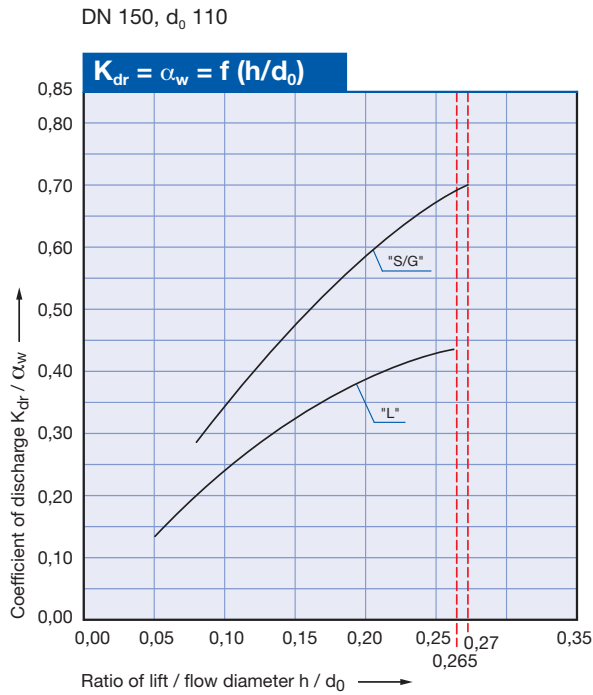
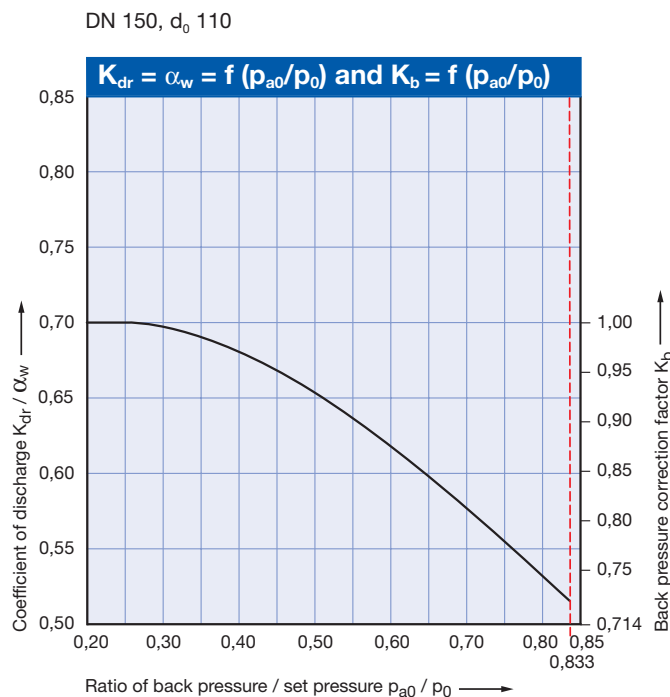
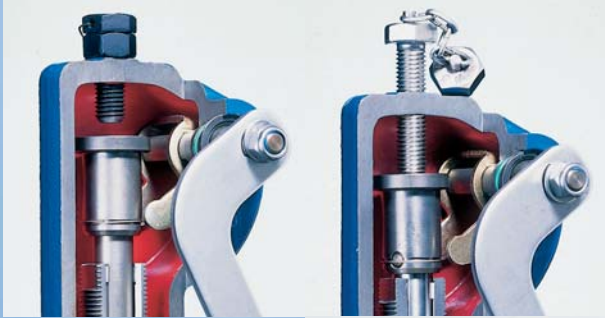
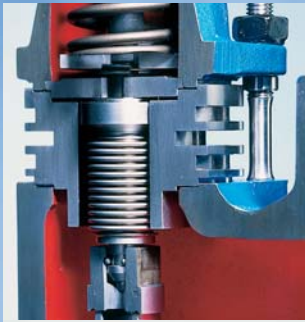

Diagram for evaluation of coefficient of discharge (K_{dr}/α_w) or K_b in reference to the ratio of back pressure / set pressure (p_{a0}/p₀)



How to use please refer to page 00/08

Accessories and Options



Contents

Chapter/Page

Overview	99/02
Caps and Levers	99/04
Caps and Levers – bolted	99/06
Metal seat	99/08
Soft seal disc	99/10
Soft seal	99/12
Balanced bellows	99/14
High temperature equipment	99/16
Elastomer bellows	99/17
Disc	99/18
Heating jacket	99/20
O-ring damper	99/22
Lift indicator	99/24
Lift restriction	99/25
First in safety	
Fax Order	

Overview

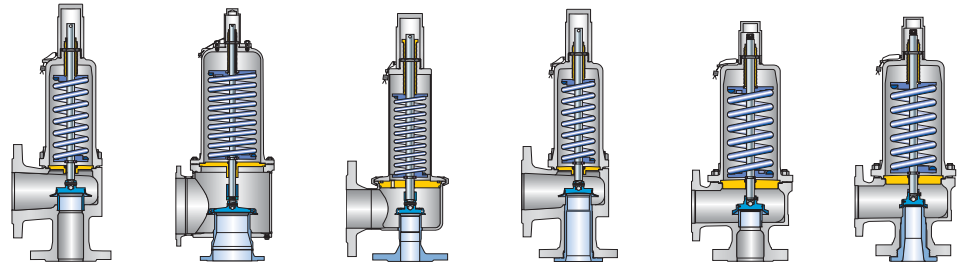

Options		441, 442 DIN 441, 442 ANSI	441, 442 XXL	444 DIN 444 ANSI	441 Full nozzle DIN 441 Full nozzle ANSI 442 Full nozzle DIN 442 Full nozzle ANSI	455/456	457/458
Disc (Item 7)							
	Disc with detachable lifting aid	✓	*	*	✓	*	*
	Bull race disc	✓	✓	✓	✓	*	*
Type of sealing (Item 5 and 7)							
Metal seat	Metal-to-metal	✓	✓	✓	✓	✓	✓
	Metal-to-metal stellite	✓	✓	✓	✓	✓	✓
Soft seat	O-ring	✓	on request	-	✓	✓	✓
	Sealing plate	✓	-	-	✓	-	-
Bellows (Item 15, item70)							
	Stainless steel	✓	✓	select 4414	✓	✓	✓
	low pressure	✓	-	select 4414	✓	on request	on request
	Hastelloy® or special materials	✓	✓	select 4414	✓	✓	✓
	High temperature equipment	-	-	-	-	✓	✓
	Elastomer	✓	-	select 4414	✓	-	-
Caps and levers (Item 40)							
	H2	✓	✓	✓	✓	✓	✓
	H3	✓	-	-	✓	✓	✓
	H4	✓	✓	✓	✓	✓	✓
Bolted	H1	-	✓	-	-	-	-
	H6	-	✓	-	-	-	-

Item – Numbers of the components please refer to standard master bill of materials and sectional drawing.

Overview

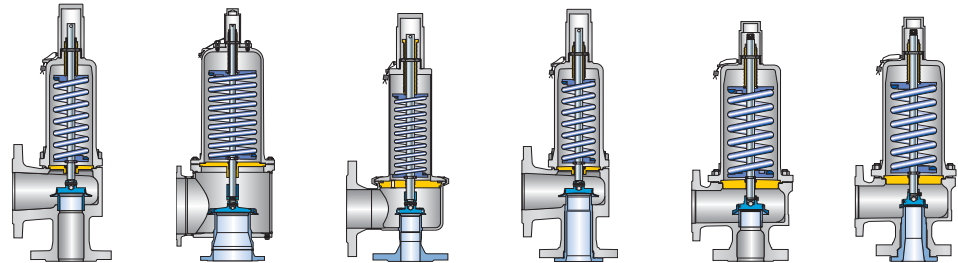

Options		Type	441, 442 DIN 441, 442 ANSI	441, 442 XXL	444 DIN 444 ANSI	441 Full nozzle DIN 441 Full nozzle ANSI 442 Full nozzle DIN 442 Full nozzle ANSI	455/456	457/458
Test gag								
	H2 (H1)	✓	✓	✓	✓	✓	✓	✓
	H4 (H6)	✓	✓	✓	✓	✓	✓	✓
Bonnet (Item 9)								
	closed	✓	✓	✓	✓	✓	✓	✓
	open	✓	✓	-	✓	✓	✓	✓
Heating jacket								
		✓	-	-	✓	✓	✓	✓
Lift indicator								
	Lifting device H2 (H1), H4 (H6)	✓	✓	✓	✓	✓	✓	✓
	bonnet	-	-	✓	-	-	-	-
Lift stopper								
	bush	✓	✓	✓	✓	✓	✓	✓
	gag	✓	✓	✓	✓	✓	✓	✓
Drain hole								
		✓	✓	-	✓	✓	✓	✓
O-ring damper (Item 40)								
	H2	✓	-	✓	✓	-	-	-
	H4	✓	-	✓	✓	-	-	-
Bursting disc KUB								
		✓	-	✓	✓	✓	✓	✓
refer to catalog "Best Availability"								

Caps and levers – Subassembly item 40

Cap H2

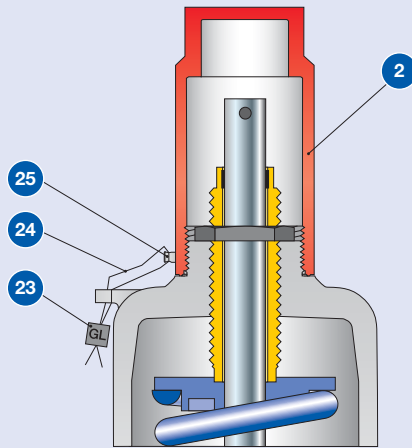

Packed lever H4

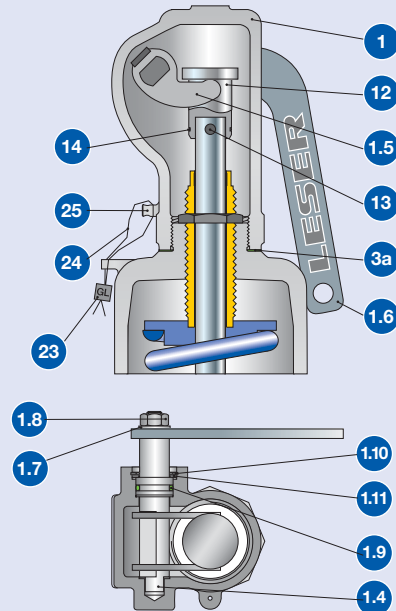

Plain lever H3

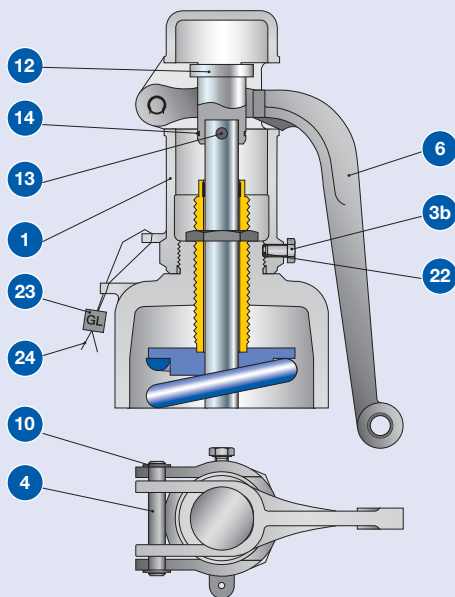

Test gag

Cap H2: J70
Packed lever H4: J69

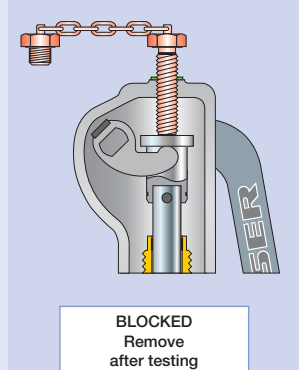
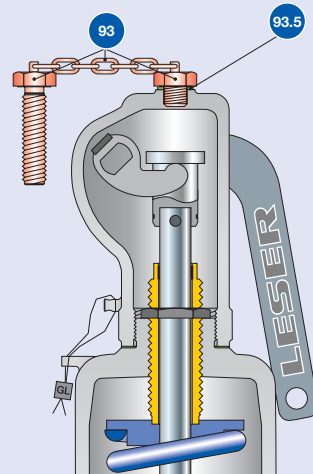

Test gag

The test gag blockades the spindle and keeps the safety valve tight while the system pressure exceeds the set pressure.

The test gag is used for:

- to perform pressure tests in a system without dismantling of the safety valve
- the individual adjustment of safety valves installed in the same system

After testing the test gag must be removed because otherwise the safety valve cannot protect the system against unallowable overpressure!

Caps and levers – Subassembly item 40

Materials		Steel			Stainless steel	
Item	Component	Cap H2	Plain lever H3	Packed lever H4	Cap H2	Packed lever H4
1	Lever cover	–	0.7040	0.7040	–	1.4408
		–	Gr. 60-40-18	Gr. 60-40-18	–	CF8M
2	Cap	1.0718	–	–	1.4404	–
		Steel	–	–	316L	–
3a	Spacer	–	–	1.4571	–	1.4571
		–	–	316Ti	–	316Ti
3b	Hex screw	–	1.4401	–	–	–
		–	B8M	–	–	–
4 / 1.4	Shaft / bolt	–	1.4021	1.0718	–	1.4404
		–	420	Steel	–	316L
1.5	Lifting fork	–	–	1.0531	–	1.4571
		–	–	Steel	–	316Ti
6 / 1.6	Lever	–	0.7040	1.0036	–	1.4301
		–	Gr. 60-40-18	Steel	–	304
1.7	Washer	–	–	1.4401	–	1.4301
		–	–	316	–	304
1.8	Nut	–	–	A2/Poly	–	1.4401
		–	–	2H	–	8M
1.9	O-ring	–	–	Viton®	–	–
		–	–	--	–	–
1.9	Bushing	–	–	–	–	Graphite
		–	–	–	–	--
10/1.10	Retaining clip	–	Carbon steel	Carbon steel	–	–
		–	--	--	–	–
1.10	Nut	–	–	–	–	1.4104
		–	–	–	–	Chrome steel
1.10	Packing gland	–	–	–	–	1.4404
		–	–	–	–	316L
1.11	Support ring	–	–	Carbon steel	–	–
		–	–	--	–	–
12	Spindle cap	–	1.0718	1.0718	–	1.4404
		–	Carbon steel	Carbon steel	–	316L
13	Pin	–	Steel	Steel	–	1.4401
		–	--	--	–	8M
14	Retaining clip	–	1.4571	1.4571	–	1.4571
		–	316Ti	316Ti	–	316Ti
22	Plug	–	Plastic	–	–	–
		–	--	–	–	–
23	Seal	Plastic	Plastic	Plastic	Plastic	Plastic
		--	--	--	--	--
24	Seal wire	1.4541	1.4541	1.4541	1.4541	1.4541
		321	321	321	321	321
25	Sealing nose	1.4435	–	–	1.4435	1.4435
		316L	–	–	316L	316L
93	Test gag	1.4401	–	1.4401	1.4401	1.4401
		B8M	–	B8M	B8M	B8M
93.5	Washer	Fiber	–	Fiber	Fiber	Fiber
		--	–	--	--	--

Please notice:

- Modifications reserved by LESER.
- LESER can upgrade materials without notice.
- Every part can be replaced by other material acc. to customer specification.

Caps and levers bolted – Subassembly item 40

Bolted Cap H1

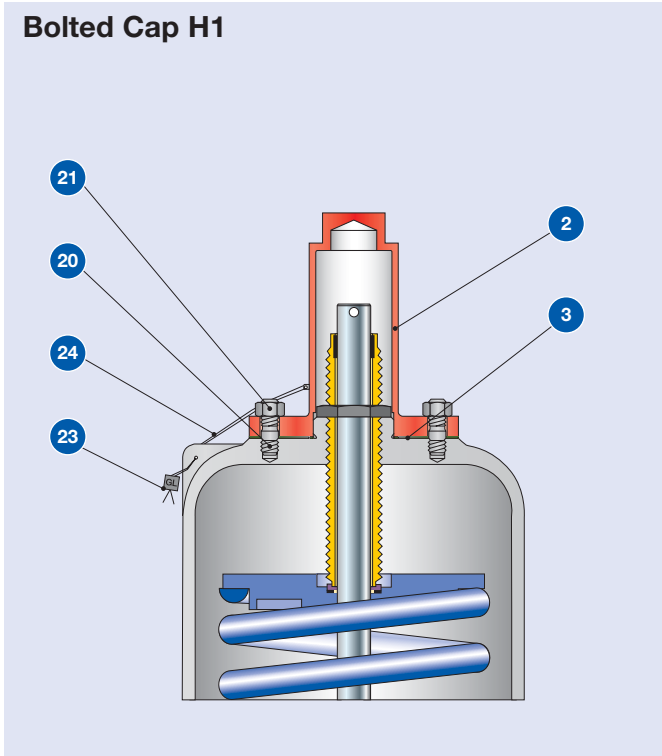

Bolted lifting device H6

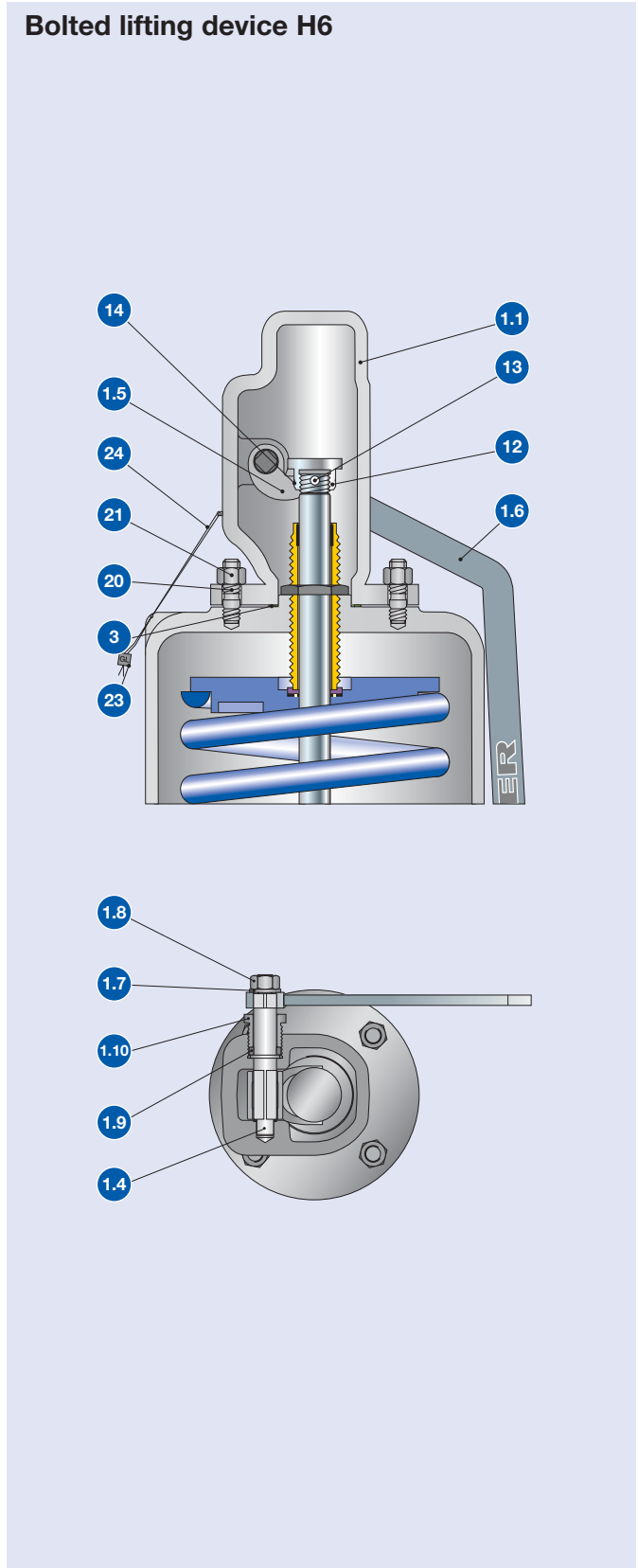

Test gag

Bolted cap H1: J70
Bolted lifting device H6: J69

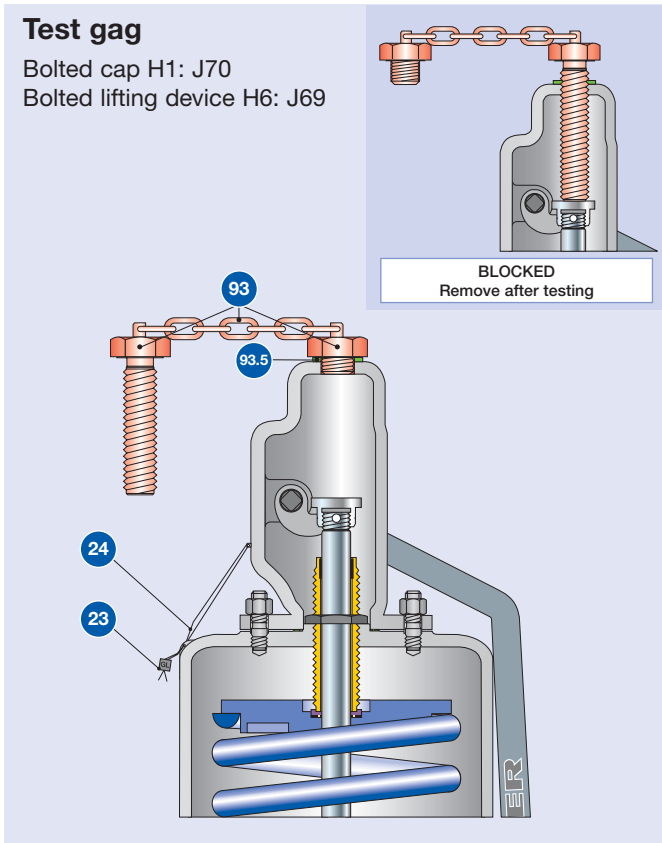
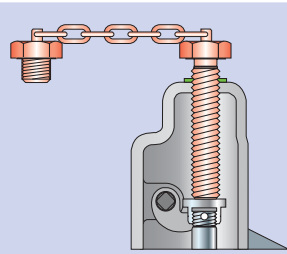

Description of the test gag please refer to page 99/04.

Caps and levers bolted – Subassembly item 40

Materials		Steel		Stainless steel	
Item	Component	Bolted cap H1	Bolted lifting device H6	Bolted cap H1	Bolted lifting device H6
1.1	Lever cover	–	0.7040	–	1.4408
		–	Gr. 60-40-18	–	CF8M
1.4	Shaft/bolt	–	1.0718	–	1.4404
		–	Steel	–	316L
1.5	Lifting fork	–	1.4408	–	1.4408
		–	CF8M	–	CF8M
1.6	Lever	–	1.0036	–	1.4571
		–	Carbon steel	–	316Ti
1.7	Washer	–	Steel	–	1.4401
		–	--	–	AISI 316
1.8	Nut	–	A4	–	1.4401
		–	2H	–	8M
1.9	Bushing	–	Graphite	–	Graphite
		–	--	–	--
1.10	Packing gland	–	1.4104	–	1.4404
		–	AISI 430F	–	316L
2	Cap	0.7040	–	1.4408	–
		Gr. 60-40-18	–	CF8M	–
3	Gasket	Graphite / 1.4401	Graphite / 1.4401	1.4571	1.4571
		Graphite / 316L	Graphite / 316L	316Ti	316Ti
12	Spindle cap	–	1.0718	–	1.4404
		–	Carbon steel	–	316L
13	Pin	–	Steel	–	A4
		–	--	–	8M
14	Retaining clip	–	1.4571	–	1.4571
		–	316Ti	–	316Ti
20	Stud	1.1181	1.1181	1.4401	1.4401
		B7	B7	B8M	B8M
21	Nut	1.0501	1.0501	1.4401	1.4401
		2H	2H	8M	8M
23	Seal	Plastic	Plastic	Plastic	Plastic
		--	--	--	--
24	Seal wire	1.4541	1.4541	1.4541	1.4541
		321	321	321	321
93	Test gag	1.4401	1.4401	1.4401	1.4401
		B8M	B8M	B8M	B8M
93.5	Washer	Fiber	Fiber	Fiber	Fiber
		--	--	--	--

Please notice:

- Modifications reserved by LESER.
- LESER can upgrade materials without notice.
- Every part can be replaced by other material acc. to customer specification.

Metal seat – Seat/nozzle item 5 and disc subassembly item 7

The LESER metal seats (disc and nozzle) are lapped to optical flatness to ensure a tight seal. LESER safety relief valves are supplied with standard leak tightness according to API 527. Improved tightness is available on request.

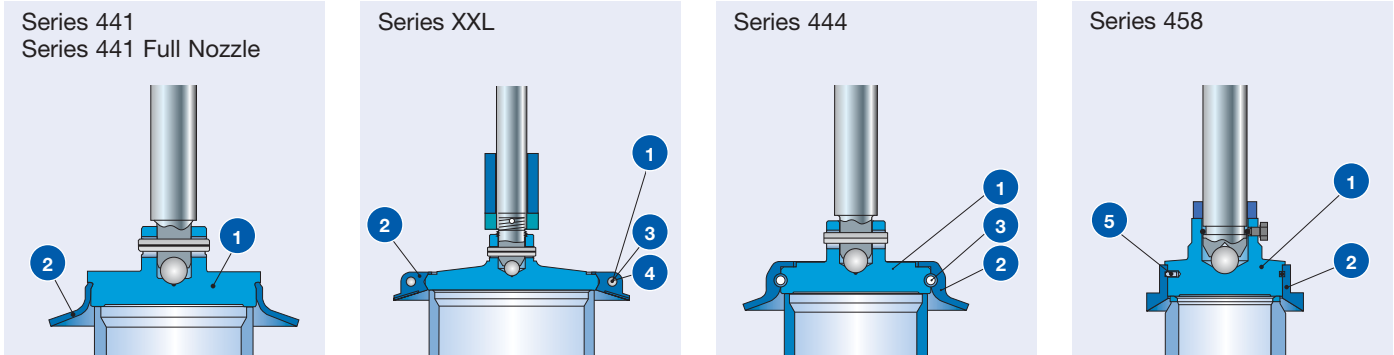

Stellited sealing surfaces

The sealing surfaces of stainless steel disc and nozzle can be stellited by build-up welding. Stellite is a cobalt-chromium based, non-ferrous alloy with increased hardness, corrosion resistance and wear resistance up to high temperatures.

LESER recommends stellited sealing surfaces for High Performance valves (seat and disc 1.4404 / 316L) in the following cases:

- high pressure applications, due to the high stress of the sealing surfaces
- high temperature applications to avoid a permanent deformation of the sealing surfaces, due to the material properties of the seat and disc
- applications with abrasive fluids to increase the wear resistance of the sealing surfaces

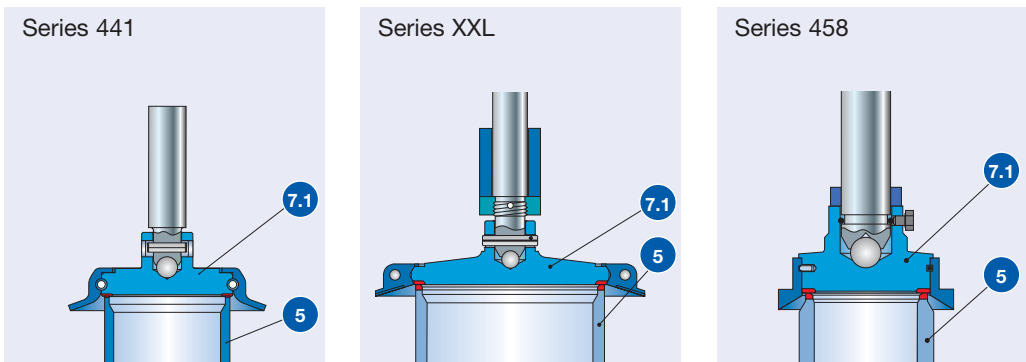

Materials for disc and seat/nozzle see page 99/09.

Hardness metal seat

Material		Hardness of sealing surfaces		
EN	ASME	Values from standards or manufacturers specification		Average value LESER stock
EN 10088-3, 1.4122 hardened	Hardened stainless steel	≥ 40 HRC	LWN 325.01 Hardening procedure	42 – 46 HRC
EN 10272, 1.4404	SA 479 316L	≤ 215 HBW	EN 10272 Table 7	16 – 19 HRC ¹⁾
EN 10272, 1.4404 stellited	SA 479 316L stellited	≥ 35 HRC	Manufacturers specification	40 HRC

HBW: BRINELL hardness acc. DIN EN ISO 6506-1 / HRC: ROCKWELL hardness acc. DIN EN ISO 6508-1

¹⁾ Rockwell hardness values below 20 HRC are not allowed according to DIN EN ISO 6508-1.

Lower, fictitious values were created for better comparison.

Metal seat – Seat/nozzle item 5 and disc subassembly item 7

Standard and corrosive service

Materials		Disc – Subassembly item 7	
Item	Component	Steel	Stainless steel
Series 441, 441 Full nozzle			
1	Disc	1.4122 hardened	1.4404
		Hardened stainless steel	316L
2	Lifting aid	1.4404	1.4404
		316L	316L
Series XXL			
1	Disc	1.4404, 1.4571	1.4404, 1.4571
		316L, 316Ti	316L, 316Ti
2	Lifting aid	1.4581, 1.4571	1.4581, 1.4571
		CF10M, 316Ti	CF10M, 316Ti
5	Screw	1.4401 B8M	1.4401 B8M
6	Nut	1.4401	1.4401
		8M	8M
7	Washer	1.4401	1.4401
		Stainless steel	Stainless steel
Series 444			
1	Disc	–	1.4404
		–	316L
2	Lifting aid	–	1.4404
		–	316L
3	Securing ring (DN 25/1" only)	–	1.4571
		–	316Ti
3	Rollpin	–	1.4310
		–	Stainless steel
Series 458			
1	Disc	1.4122 hardened	1.4404
		Hardened stainless steel	316L
2	Lifting aid	1.4404	1.4404
		316L	316L
3	Securing ring	1.4571	1.4571
		316Ti	316Ti

Materials		Seat / nozzle – Item 5	
Item	Component	Steel	Stainless steel
All Series			
5	Seat / nozzle	refer to respective master bill of materials	

Stellited sealing surfaces

Materials		Seat / nozzle – Item 5, disc – Item 7	
Item	Component	Option code	
Series 441, XXL, 458			
7.1	Disc	J25	1.4404 stellited, 1.4571 stellited
			316L stellited, 316Ti stellited
5	Seat / nozzle	L61 / L62	1.4404 stellited, 1.0305 stellited, 1.4571 stellited
			316L stellited, carbon steel stellited, 316Ti stellited

Soft seal disc – Subassembly item 7

LESER soft seal solutions allow for superior tightness.

Features and Benefits

- two different designs with o-ring or sealing plate (Series 441 and 441 Full Nozzle only) for a wide variety application
- large selection of soft seal materials to best adapt to the application
- increased service life of sealing surfaces compared to a metal to metal seat
- simple replacement of the soft seal reduces maintenance costs
- standard ARP O-ring sizes for easy worldwide procurement
- one standard durometer per O-ring material for all set pressures to reduce stocking expenses

Design of soft seal

O-ring disc

Series 441
Series 441 Full Nozzle

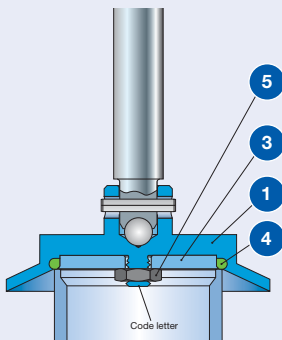

Series XXL

*Please contact LESER
for special design
sales@leser.com*

Series 458

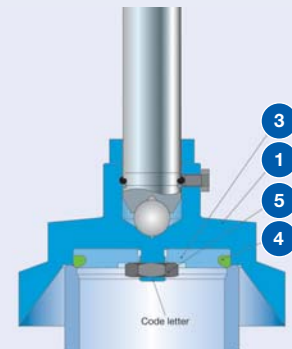

Design of soft seal

Disc with sealing plate

Series 441
Series 441 Full Nozzle

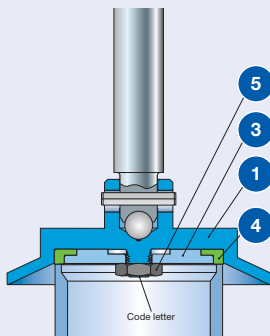

For temperature limits, medium resistance and option codes please refer to the soft seal selection table, page 99/12.
Materials for soft seal discs see page 99/11.

Soft seal disc – Subassembly item 7

Materials		O-ring disc	
Item	Component	Steel	Stainless steel
Series 441, 441 Full nozzle, 458			
1	Disc with lifting aid	1.4404 316L	1.4404 316L
3	Retainer	1.4404 316L	1.4404 316L
4	O-ring	See soft seal selection table page 99/12	See soft seal selection table page 99/12
5	Nut	1.4401 8M	1.4401 8M

Materials		Disc with sealing plate	
Item	Component	Steel	Stainless steel
Series 441, 441 Full nozzle			
1	Disc with lifting aid	1.4404 316L	1.4404 316L
3	Retainer	1.4404 316L	1.4404 316L
4	Sealing plate	See soft seal selection table page 99/12	See soft seal selection table page 99/12
5	Nut	1.4401 8M	1.4401 8M

Soft seal

Soft seal selection								
Abbreviation ASTM 1418	Trade name (Designation)	Code- letter ¹⁾	Option Code	T _{min}		T _{max}		Application ²⁾
				[°C]	[°F]	[°C]	[°F]	
O-ring								
CR	Neoprene®	K	J21	-40	-40	100	212	Parafin oil, silicone oil and grease, water and waterbased solvents, refrigerants, ozone
NBR	Buna-N® (Nitrile-Butadiene)	N	J30	-25	-13	100	212	Hydraulic oil, vegetable and animal grease and oil
EPDM	Buna-EP® (Ethylene-Propylene-Diene)	D	J22	-45	-49	150	302	Hot water and superheated steam up to 150 °C, 302 °F, some organic and inorganic acids, silicone oil and grease, FDA compliant
FKM	Viton® (Fluorocarbon)	L	J23	20	-4	180	356	High temperature service (no superheated steam), mineral oil and grease, silicone oil and grease, vegetable and animal grease and oil, ozone, FDA compliant compound available on request
FFKM	Kalrez® (Perfluoro)	C	J20	0	32	250	482	Nearly all chemicals, standard compound is Kalrez® 6375 with steam resistance, FDA compliant compound available on request
Sealing plate								
SP	VESPEL SP-1® ³⁾ (Polyimide)	T	J49	-270	-454	300	572	High temperature and high pressure applications (no steam), for chemical resistance refer to manufacturers guide
PCTFE	KEL-F® (Polychlorotrifluoroethylene)	G	J48	-270	-454	204	400	Cryogenic and refrigeration applications, flammable media applications, (e.g. gaseous oxygen) up to 50 bar, 725 psig at 60 °C, 140 °F
PTFE	Teflon® (Polytetrafluoroethylene)	A	J44	-184	-300	150	302	Nearly all chemicals
Other than listed		X	For other materials please contact your local representative or sales@leser.com					

¹⁾ The code letters will be stamped on the disc (Item 1).

²⁾ Pressure and temperature service must be considered in any case.

Chemical resistance information is supplied by the O-ring manufacturer. LESER can not take any warranty.

³⁾ For valve size DN 25, 1" x 2" only.

Soft seal

Soft seal disc		Set pressure and size limits				DIN Valve size
Material	Pressure range					
	min.		max.			
	[bar]	[psig]	[bar]	[psig]		
Series 441, 441 Full nozzle						
CR NBR EPDM FKM FFKM	0,1	1,5	51	740	DN 20 – 150 1" – 6"	
VESPEL SP-1®	10	150	51	740	DN 25 1"	
Kel-F®	1	15	51	740	DN 25 – 125 1" – 5"	
Teflon®	1	15	10	145	DN 25 – 125 1" – 5"	
Series 458						
CR NBR EPDM FKM FFKM	–	–	–	–	DN 25/1", d ₀ 15	
	4	9	105	225	DN 25/1", d ₀ 20	
	8,6	19	102	225	DN 50/2", d ₀ 30	
	3,5	8	102	225	DN 50/2", d ₀ 40	
	4	9	77	170	DN 80/3", d ₀ 50	
	5	11	77	170	DN 80/3", d ₀ 60	
	4	9	77	170	DN 100/4", d ₀ 50	
	5	11	77	170	DN 100/4", d ₀ 60	
	2,5	6	60	132	DN 100/4", d ₀ 74	
	2,5	6	51	112	DN 100/4", d ₀ 88	
2,5	6	40	88	DN 150/6", d ₀ 110		

Trademarks	Soft seal
Registered trademarks	Company
Buna-N®, Teflon® Viton®, VESPEL SP-1® Neoprene®, Kalrez®	DuPont
Buna EP®	Bayer
Kel-F®	3M

Balanced bellows – Subassembly item 15

LESER is able to provide a balanced bellows design through the use of stainless steel bellows.

Balanced bellows are generally used for two applications:

- to compensate for back pressure
- to seal off the bonnet from the outlet chamber

Compensation for back pressure

The back pressure acts on the reverse side of the disc, creating a force in the closing direction (F_c) of the safety valve. The magnitude of this force depends on the seat area and the level of the back pressure. The balanced bellows constitute an opposite area with the same area like the seat. The back pressure acts on, thereby reducing or eliminating the closing force. This reduction of the force in the closing direction can be viewed as a compensating force acting in the opening direction (F_o).

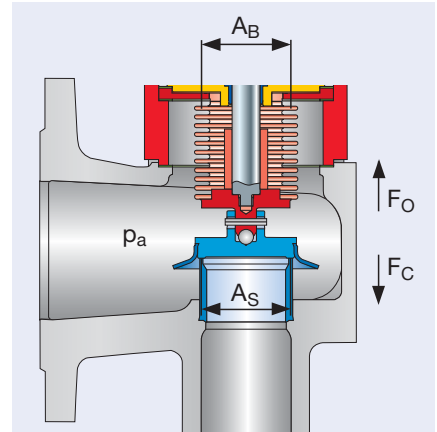

A quantitative representation is shown in the table below:

Actual area	Back pressure	Actual force	Direction of force	Compensation criteria
Seat area = A_s	p_a	$F_c = p_a \times A_s$	closing	$A_s = A_b$
Bellows area = A_b	p_a	$F_o = p_a \times A_b$	opening	$F_c = F_o$

Sealing the bonnet from the outlet chamber

LESER's balanced bellows reliably seal the bonnet from the outlet chamber; protecting the guide, moving parts and the spring from problems associated with the fluid, such as dirt, corrosion, impurities of temperature.

Balanced bellows

Series	441, 441 Full nozzle	XXL	458
Design			
Bonnet spacer	*	-	*
Bellows housing	-	*	*
The bellows housing protects the bellows against turbulences during discharge to avoid bellows vibration and to guarantee a longer life-time.			
Control thread	DIN ISO 228-1, G 1/4	*	*
	ASME B1.20.1 NPT 1/2	✓	✓

A control thread DIN ISO 228-1 size G 1/4 is fitted into the bonnet to monitor the condition of the bellows. A discharge pipe can be fitted to the G 1/4 control thread to allow safe discharge of aggressive or toxic fluids.

Option code

Open bonnet	Standard bellows	J68	J68	J68
	Low pressure bellows	J68, J63	J68, J63	J68, J63
	Other materials than stand.	S15 + material designation	S15 + material designation	S15 + material designation
Closed bonnet	Standard bellows	J78	J78	J78
	Low pressure bellows	J78, J63	J78, J63	J78, J63
	Other materials than stand.	S15 + material designation	S15 + material designation	S15 + material designation
	Control thread NPT 1/2	J95	J95	J95

The dimensions and weights of a safety valve with balanced bellows are displayed in the tables "Dimensions and weights" for each type. The set pressure range as well as the temperature range are displayed in the tables "Pressure temperature ratings" for each type.

Balanced bellows – Subassembly item 15

Materials		Standard bellows		
Item	Component	Series 441, 441 Full nozzle	Series XXL	Series 458
15.1	Lower adaptor	1.4404	1.4404	1.4404
		316L	316L	316L
15.2	Upper adaptor	1.4404	1.4571	1.4404
		316L	316Ti	316L
15.3	Bellows	1.4571	1.4571	1.4571
		316Ti	316Ti	316Ti
15.5	Housing	–	1.4571	see item 11
		–	316Ti	--
11	Bonnet spacer	1.4404	–	1.0460 or 1.4404
		316L	–	Carbon steel or 316L
55	Studs	1.4401	1.4401	1.7709
		B8M	B8M	B16
60	Gaskets	Graphite / 1.4401	–	Graphite / 1.4401
		Graphite / 316	–	Graphite / 316

Hastelloy bellows or special materials are available on request.

Materials		Special bellows		
Hastelloy®		✓	✓	✓
Inconel®		✓	✓	✓

Balanced bellows conversion kits

LESER balanced bellows conversion kits are available to convert from a conventional design into a balanced bellows design with little effort. The conversion kits contain all the necessary parts for conversion as well as instructions.

Conversion kits				
Item	Component	Quantity	Material	Remarks
8	Guide	1	1.4404	
			316L	
11	Bonnet spacer	1	1.4404	
			316L	
12	Spindle	1	1.4404	
			316L	
15	Bellows	1	1.4571	
			316Ti	
55	Stud	4, 8, 12 depends on valve size	1.4401	
			B8M	
60	Gasket	2, 3 depends on valve size	Graphite / 1.4401	
			Graphite / 316	
–	Installation instruction	1		LWN 037.05

For article no. and spare parts please refer to spare part page for each type.

High temperature equipment

For fluid temperatures higher than 400 °C / 752 °F high temperature equipment is necessary to protect the inner parts and the spring against inadmissible influence of temperature. The maximum inlet temperature is 550 °C / 1022 °F. The equipment shown is only fitted in Type 457 / 458. For all other Types an open bonnet and a stainless steel bellows is necessary for fluid temperatures exceeding 400 °C / 752 °F up to max. 450 °C / 842 °F.

Specification

Series 458

Design

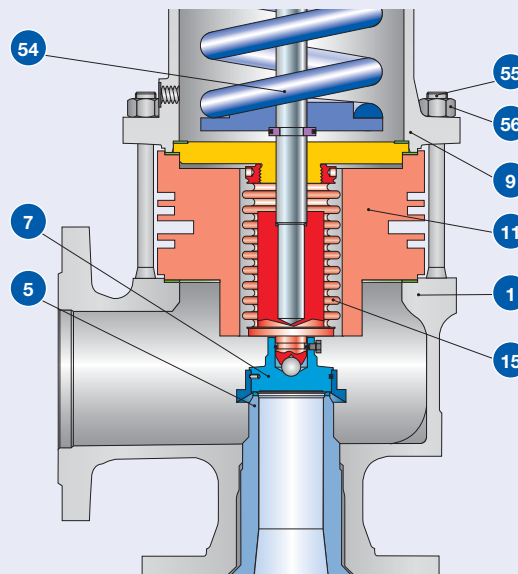

Option code

J88

Operating conditions

Temperature limits	[°C]	> 400 fluid temperature
	[°F]	> 752 fluid temperature
	max. [°C]	550 inlet temperature
	max. [°F]	1022 inlet temperature

Materials

High temperature equipment

Item	Component	
1	Body	1.7357
		WC6
5	Nozzle	1.4404
		316L
7	Disc	1.4404 stellited
		316L stellited
9	Bonnet open	1.0619
		WCB
11	Cooling spool	1.4404
		316L
15	Bellows	1.4571
		316L
54	Spring	1.7102, 1.8159
		High temperature alloy steel
55	Studs	1.7709
		B16
56	Nuts	1.7258
		7M

Elastomer bellows

Application

Elastomer bellows reliably seal the bonnet from the outlet chamber, protecting the guides, moving parts and the spring from problems associated with the media, such as dirt, corrosion or impurities, which can cause the valve to fail. The elastomer bellows is a cost effective alternative to the stainless steel bellows.

The range of application for the elastomer bellows is limited by:

- chemical resistance of the bellows
- fluid temperature
- set pressure
- back pressure

Elastomer bellows

Design	
Bellows design	The bellows simple, compact, single wall design allows it to be used in small relieving spaces. Its one-piece construction also allows to be easily replaced and extends its service life.
Flexibility	The bending of the elastomer bellows provides maximum flexibility for spindle movement and reduces wear.
Bonnet vent	A control bore Ø 10 mm / 0,4 inch is designed in the bonnet to vent and to monitor the tightness of the bellows.
Design height	No alteration.

Materials

		Valve size	DN 20 – 65	DN 80 – 150	DN 20 – 150
			1" – 3"	4"	1" – 4"
		Option code	J79	J79	J87
Item	Component				
70	Elastomer Bellows	70 EPDM 281	55 EPDM 259	45 NBR 670 optional	
		--	--	--	
71	Hose clamp	1.4301	1.4301	1.4301	
		304	304	304	
72	Hose clamp	1.4301	1.4301	1.4301	
		304	304	304	

Operating conditions

Temperature limits	[°C]	-50 up to +130	-50 up to +130	-25 up to +100
	[°F]	-58 up to +266	-58 up to +266	-13 up to +212
Set pressure	max. [bar _g]	10		
	max. [psig]	145		
Built-up back pressure	[bar _g]	up to 3		
	[psig]	up to 43,5		

Disc – Subassembly item 7

Disc with detachable lifting aid

As a variation on the standard disc with an integrally fixed lifting aid, a detachable lifting aid for the disc can be supplied if requested. The advantage when servicing the safety valve is that damage to the sealing surface can be rectified on site by removal and lapping.

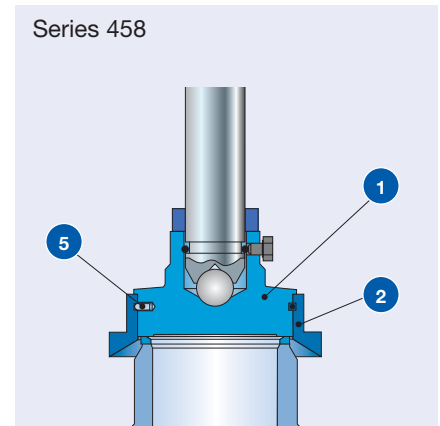
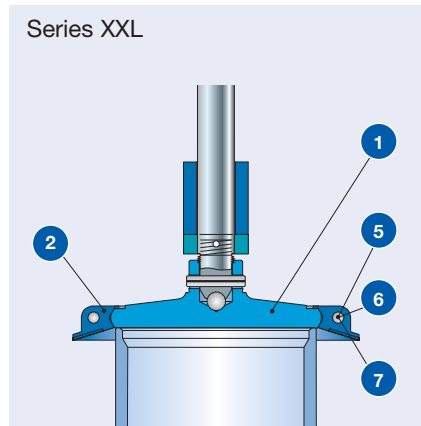
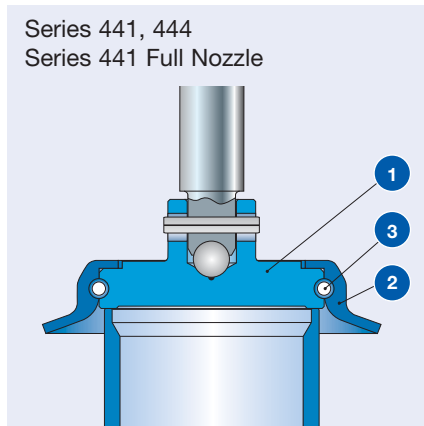

Materials see page 99/19.

Bull race disc

To avoid damages on the sealing surfaces due to frequent dismantling, specially on safety valves which have shortand/or regular maintenance intervals, a bull race disc can be supplied. For Series 458 a bull race disc is standard.

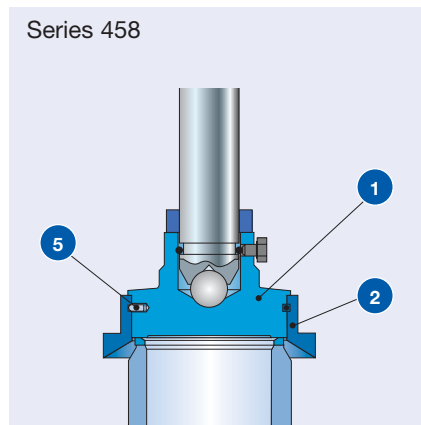
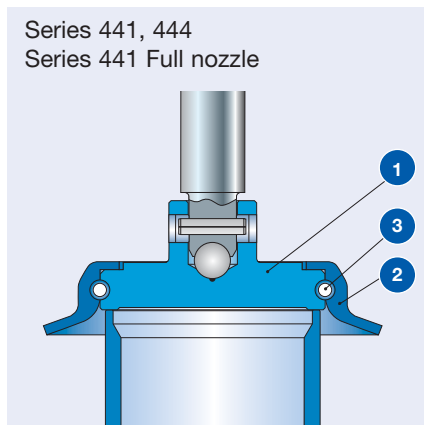

Availability						
Type	441, 442 DIN 441, 442 ANSI	441, 442 XXL	444 DIN 444 ANSI	441 Full nozzle DIN 441 Full nozzle ANSI 442 Full nozzle DIN 442 Full nozzle ANSI	455/456	457/458
Disc	Option code					
Disc with detachable lifting aid	J26	*	*	J26	*	*
Bull race disc	J24	J24	J24	J24	*	*

Disc – Subassembly item 7

Materials		Disc with detachable lifting aid	
Item	Component	Standard service	Corrosive service
Series 441, 441 Full nozzle			
1	Disc	1.4122 hardened	1.4404
		Hardened stainless steel	316L
2	Lifting aid	1.4581	1.4581
		CF10M	CF10M
3	Rollpin	1.4310	1.4310
		Stainless steel	Stainless steel
Series XXL			
1	Disc	1.4404	1.4404
		316L	316L
2	Lifting aid	1.4581	1.4581
		CF10M	CF10M
5	Screw	1.4401	1.4401
		Stainless steel	Stainless steel
6	Nut	1.4401	1.4401
		Stainless steel	Stainless steel
7	Washer	1.4401	1.4401
		Stainless steel	Stainless steel
Series 458			
1	Disc	1.4122 hardened	1.4404
		Hardened stainless steel	316L
2	Lifting aid	1.4404	1.4404
		316L	316L
5	Securing ring	1.4571	1.4571
		316Ti	316Ti

Heating jacket

Application and design

Safety valves in systems which need to be protected from media that are viscous, sticky, or have the tendency to crystallize out of solution can be fitted with a heating jacket.

The heating jacket is constructed with a welded design and covers the body, allowing heating medias (steam, heat transfer oil, etc.) to pass through the space created.

To protect the spindle and the moving parts against sticking LESER recommends the use of a heating jacket in combination with the balanced bellows design.

For safety valves with balanced bellows, the bonnet spacer required to house the bellows is fitted with an additional heating jacket. Both heating jackets are joined by a tubing.

If there is no risk of solidification of the media at the outlet a safety valve without balanced bellows can be used as well.

The position of the heating connections is shown in figure 1 to 3.

Specifications of the Heating Jacket

The operating data for the heating jacket are shown on a separate name plate.

Slip on flanges

Flanged heating connections are supplied as slip on flanges for better alignment of the flange connection.

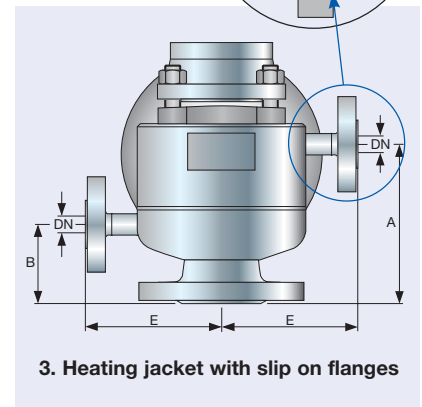
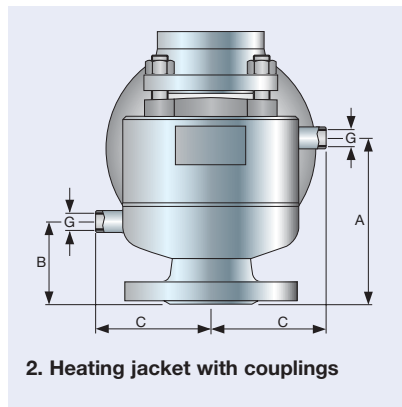
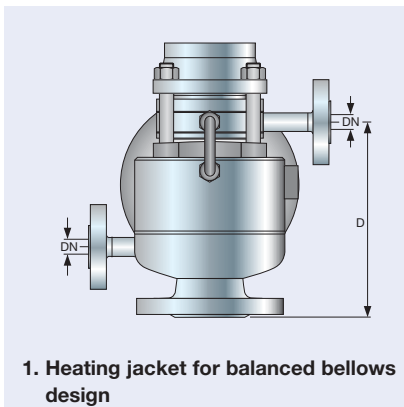
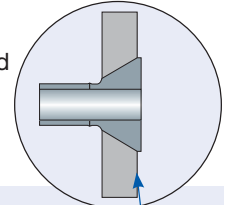

Heating jacket													
	DN _i	25	32	40	50	65	80	100	125	150	200	≥ 250	
	Valve size inlet	1"	1 1/2"	1 1/2"	2"	2 1/2"	3"	4"	5"	6"	8"	≥ 10"	
	Actual Orifice diameter d ₀ [mm]	23	29	37	46	60	74	92	98	125	165	≥ 200	
Materials													
Body	Series 441					1.4408	1.4408	1.4408	1.4408	1.4408			
	Series 441 Full nozzle	1.4408	1.4408	1.4408	1.4408	optional 1.0619	optional 1.0619	optional 1.0619	optional 1.0619	optional 1.0619	1.0619	-	
	Series XXL	-	-	-	-	-	-	-	-	-	1.0460 1.0425	1.0460 1.0425	
	Series 458	1.4581	1.4581	1.4581	1.4581	optional 1.0619	optional 1.0619	optional 1.0619	optional 1.0619	optional 1.0619	-	-	
Heating jacket						1.4541 321							
Connections													
Slip on flange	Option code	DN 15, PN 25	1.4571, 1.4404						-				
			316Ti, 316L						-				
DIN	Option code	DN 25, PN 25	-						1.4571, 1.4404				
			-						316Ti, 316L				
Slip on flange	Option code	1/2", CL150	1.4404						-				
			316L						-				
ANSI B16.5	Option code	1", CL150	-						1.4404				
			-						316L				
Couplings	Option code	G 3/8					1.4571						
							316Ti						
DIN 2986	Option code	G 3/4					1.4571						
							316Ti						
Heating jacket spacer	Option code	H 33					1.4404						
							316L						

Heating jacket

Metric Units												
	DN _i	25	32	40	50	65	80	100	125	150	200	≥ 250
	Valve size inlet	1"	1 1/2"	1 1/2"	2"	2 1/2"	3"	4"	5"	6"	8"	≥ 10"
	Actual Orifice diameter d ₀ [mm]	23	29	37	46	60	74	92	98	125	165	≥ 200
Series 441, Series 441 Full nozzle, Series XXL												
Dimensions												
[mm]	A	115	130	160	160	200	165	160	170	390	on request	on request
	B	70	70	75	80	90	80	80	125	125	on request	on request
	C	95	95	110	110	135	145	145	162	162	on request	on request
	D	152	170	198	220	255	300	300	370	445	on request	on request
	E	121	121	121	136	161	176	176	200	200	on request	on request
	Slip on flange DN	15	15	15	15	15	25	25	25	25	25	25
[inch]	Couplings G	3/8	3/8	3/8	3/8	3/8	3/4	3/4	3/4	3/4	3/4	3/4
Operating conditions												
Operating pressure [bar]												
Operating temperature	20°C	25	25	25	25	15	15	15	15	12	12	on request
	300°C	18	18	18	18	11	11	11	11	9	9	on request
Series 458												
Dimensions												
[mm]	A	130	–	–	170	–	on request	on request	–	–	–	–
	B	88	–	–	112	–	on request	on request	–	–	–	–
	C	96	–	–	123	–	on request	on request	–	–	–	–
	D	185	–	–	251	–	on request	on request	–	–	–	–
	E	122	–	–	149	–	on request	on request	–	–	–	–
	Slip on flange DN	15	–	–	15	–	on request	on request	–	–	–	–
[inch]	Couplings G	3/8	–	–	3/8	–	on request	on request	–	–	–	–
Operating conditions												
Operating pressure [bar]												
Operating temperature	20°C	25	–	–	15	–	15	12	–	–	–	–
	300°C	18	–	–	11	–	11	9	–	–	–	–
US Units												
	DN _i	25	32	40	50	65	80	100	125	150	200	≥ 250
	Valve size inlet	1"	1 1/2"	1 1/2"	2"	2 1/2"	3"	4"	5"	6"	8"	≥ 10"
	Actual Orifice diameter d ₀ [mm]	23	29	37	46	60	74	92	98	125	165	≥ 200
Series 441, Series 441 Full nozzle, Series XXL												
Dimensions												
[inch]	A	4 1/2	5 1/8	6 5/16	6 5/16	7 7/8	6 1/2	6 5/16	6 11/16	15 3/8	on request	on request
	B	2 3/4	2 3/4	3	3 1/8	3 1/2	3 1/8	4 1/2	5	5	on request	on request
	C	3 3/4	3 3/4	4 5/16	4 5/16	5 5/16	5 11/16	6 3/8	6 3/8	6 3/8	on request	on request
	D	6	6 11/16	7 13/16	8 11/16	10 1/16	11 3/4	13 3/8	14 5/8	17 1/2	on request	on request
	E	4 3/4	4 3/4	4 3/4	5 3/8	6 3/8	6 15/16	7 7/8	7 7/8	7 7/8	on request	on request
	Slip on flange DN _i	1/2	1/2	1/2	1/2	1/2	1	1	1	1	1	1
[inch]	Couplings G	3/8	3/8	3/8	3/8	3/8	3/4	3/4	3/4	3/4	3/4	3/4
Operating conditions												
Operating pressure [psig]												
Operating temperature	68°F	363	363	363	363	217	217	217	217	174	174	on request
	572°F	261	261	261	261	160	160	160	160	131	131	on request
Series 458												
Dimensions												
[inch]	A	130	–	–	170	–	on request	on request	–	–	–	–
	B	88	–	–	112	–	on request	on request	–	–	–	–
	C	96	–	–	123	–	on request	on request	–	–	–	–
	D	185	–	–	251	–	on request	on request	–	–	–	–
	E	122	–	–	149	–	on request	on request	–	–	–	–
	Slip on flange DN	1/2	–	–	1/2	–	on request	on request	–	–	–	–
[inch]	Couplings G	3/8	–	–	3/8	–	on request	on request	–	–	–	–
Operating conditions												
Operating pressure [psig]												
Operating temperature	68°F	363	–	–	217	–	217	174	–	–	–	–
	572°F	261	–	–	160	–	160	131	–	–	–	–

O-ring damper – Subassembly item 40

The O-ring damper can be employed to suppress or reduce oscillations of moving parts in a safety valve.

Background:

In every spring loaded safety valve the movable parts disc, spindle, lower spring plate and the spring form a so called spring-mass system. As with all spring-mass systems, these parts can become excited by unfavorable operating conditions (e.g. inlet pressure drop) or by vibrations transferred from other equipment. Vibrations occurring at resonance frequency can cause the safety valve to undergo rapid, uncontrolled opening and closing, which will cause the valve to function improperly and not allow it to relieve the certified capacity.

In general two kinds of uncontrolled oscillations exist (definitions according to ASME PTC 25-2001, chapter 2.7):

chatter: “Abnormal rapid reciprocating motion of the movable parts of a pressure relief valve in which the disc contacts the seat.” Causes for chattering are, among other things, high pressure losses in the inlet piping, excessive built-up back pressure and operation of the valve in the partial load range.

flutter: “Abnormal rapid reciprocating motion of the movable parts of a pressure relief valve in which the disc does not contact the seat.” Causes for fluttering are vibrations with small or hardly measurable amplitude, where high frequency vibrations accumulate from external influences. The vibrations are usually induced by separate units (e.g. motors, pumps) and transmitted via a mechanical connection or the medium to the safety valve.

LESER developed the O-ring damper at LESER’s certified test labs based on long experience in the operation of safety valves. The O-ring damper is able to completely stabilize function or reduce oscillations to slow, uncritical movements. Also, the safety valve will still operate within the required ranges of the applicable codes and standards. Due to its design, the O-ring damper is able to be used for any type of oscillation.

LESER offers the O-ring damper incorporated in the gastight cap H2 or in a modified lifting device H4 with packed lever. For applications with lubricating fluids, e.g. oil, the balanced bellows design must be selected to protect the O-ring damper from the fluid.

Available designs

		Cap H2	Packed lever H4
Design			
Option code	Conventional design	J65	J66
	Balanced bellows design	J65, J78	J66, J78
Temperature range O-ring		-20 °C – +180 °C -4 °F – +356 °F	

O-ring damper – Subassembly item 40

Availability

Cap H2 and Packed lever H4	
Valve size	Pressure range
Series 441	
DN 25 – DN 50	0,5 – 40 bar
1" – 2"	7,25 – 580 psig
DN 65	0,26 – 40 bar
2 1/2"	3,77 – 580 psig
DN 80	0,60 – 22,5 bar
3"	8,70 – 326 psig
DN 100	1,17 – 19,2 bar
4"	17 – 278 psig
Series 458	
DN 25, d ₀ 20	30 – 90 bar
1", d ₀ 20	435 – 1305 psig
DN 50, d ₀ 40	32 – 67 bar
2", d ₀ 40	464 – 971 psig

LESER has ensured proper performance of the O-ring damper through extensive tests at its certified test labs. If an O-ring damper is required for a set pressure not listed in the table above further testing must be performed, which will require a longer lead time; please contact sales@leser.com.

Materials

Item	Component	Cap H2	Packed lever H4
1	Lever cover	–	1.4408
		–	CF8M
2	Cap H2	1.4404	1.4404
		316L	316L
13	Parallel pin	–	1.4401
		–	B8M
14	Securing ring	–	1.4571
		–	316Ti
15	Spindle	–	1.4404
		–	316L
22	Opposite ring	1.4404	1.4404
		316L	316L
27	Bush	1.4404	–
		316L	–
27	Nozzle	–	PFTE 15% glas
		–	–
82	Spring	1.4310	1.4310
		Stainless steel	Stainless steel
83	O-ring	Viton®	Viton®
		–	–

Lift indicator

The lift indicator is a useful device that can be used in process control to monitor the operating status of a safety valve.

To detect lifting, LESER provides a special lifting device H4 incorporating a proximity switch (see drawing right).

The lift indicator will detect a safety valve lift equal to or more than 1 mm / 0.04 in, which may be the result of overpressure or of operation of the lifting device.

LESER provides inductive DC proximity switches, type DIN EN 60947-5-6 (NAMUR) using two-wire technology. These intrinsically safe proximity switches can be used in explosion hazard area zone 0 (Ex II 1 D Ex iaD 20 T6). Other types of proximity switch may be used. If a technical specification is supplied along with the type of connection thread LESER can verify compatibility.

For technical details of proximity switch refer to manufacturers homepage: www.pepperl-fuchs.com

For assembly and adjustment refer to LESER works standard LWN 323.03-E.

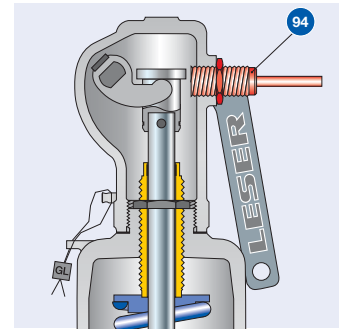

Packed lever H4 or bolted H6

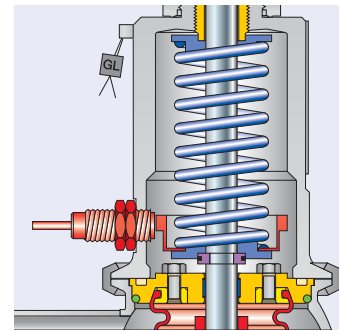

Type 444 DN 25 / 1":
Bonnet with adaptor for lift indicator

Availability

Item	Component	Option code
9	Bonnet with adaptor for lift indicator	J38
40	Lifting device H4 with adaptor for proximity switch M18 x 1 [mm]	J39
94	Lift indicator M18 x 1, used type = PEPPERL+FUCHS NJ5-18GK-N	J93

Operating chart

A, closed position

The lift indicator is positioned in front of the coupling or control sleeve when the safety valve is closed.

B, open position

When the safety valve opens or is lifted (in both cases at least 1 mm / 0,04 inch), the lift indicator changes its signal. The signal also changes if the lift indicator accidentally becomes loosened or unscrewed (fail safe).

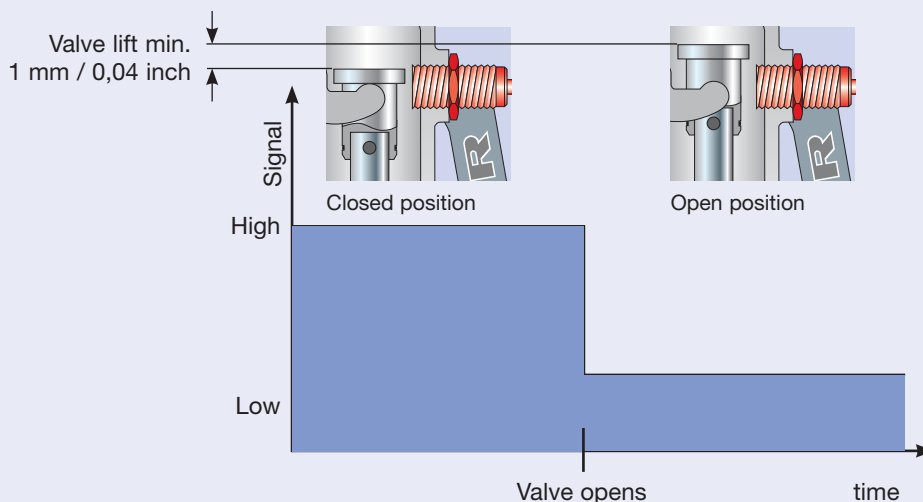

Lift restriction (lift restraining device)

A lift restriction may be needed to reduce the certified discharge capacity of a safety valve to the required discharge capacity. The lift restriction does not interfere with the operation of the valve.

If a lift restriction is used the following requirements of codes and standards must be considered.

Requirements			
Code / standard	EN ISO 4126-1, section 5.1.3	ASME Code case 1945-4	AD 2000-Merkblatt A2, section 10.3
Lift	≥ 30% full rated lift not less than 1,0 mm / 1/16 inch	≥ 30% full rated lift not less than 0,08 inch / 2,0 mm	not less than 1,0 mm / 1/16 inch
Coefficient of discharge	-	-	$\alpha_w [S/G] \geq 0,08$
	-	-	$\alpha_w [L] \geq 0,05$
Name plate marking	Marking of reduced coefficient of discharge	- Capacity replaced with "Restricted capacity" - Restricted lift = ____ inch / mm	Marking of reduced coefficient of discharge
Design according to ASME code case 1945-4	The restriction of valve capacity shall be permitted only by the use of a lift restraining device, which shall limit valve lift and shall not otherwise interfere with flow throughout of the valve. The lift restricting device shall be designed so that the adjustable feature can be mechanically locked and have access sealed.		

Determinating the restricted lift

Determining the restricted lift can be done by using:

- the "Diagram for evaluation of ratio of lift / flow diameter (h/d₀) in reference to the coefficient of discharge". An explanation on how to use this diagram may be found on page 00/08.
- LESER sizing program "VALVESTAR®"
- LESER sizing web page www.valvestar.com

Lift restrictions

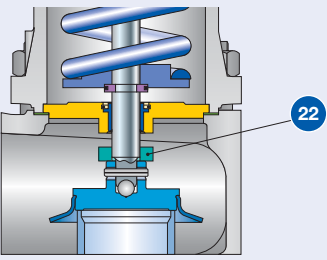
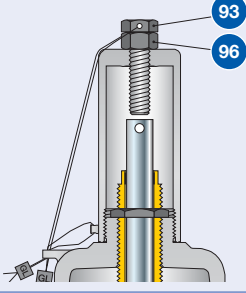
	Lift restriction by bush	Lift restriction by gag
Design		
Option code	J51	Cap H2 or H1: J52 Packed lever H4 or H6: J50
Availability		
Series 441	✓	✓
Series 444	✓	✓
Series XXL	✓	✓
Series 441 Full nozzle	✓	✓
Series 458	✓	✓
Materials		
Item	Component	
22	Bush	1.4404
		316L
93	Stud	-
		1.4401 B8M
96	Hex nut	-
		1.4401 8M

... a not so brief history of LESER

Headquartered in Germany, with a state of the art factory and more than 300 employees LESER are supplying high quality safety valves all over the world.



The company started in Germany in 1818, more than 185 years ago, as a brass foundry and developed a product portfolio of components of mechanical equipment and machines during the "industrial revolution".

In 1885 the company delivered its first safety valve and since the 1970's LESER has specialized only in safety valves.

Since the 1980's LESER has been the leading supplier for safety valves in Europe and strengthens this position each year. Currently LESER are expanding its activities worldwide.



Safe solutions from the specialist

Today, LESER's product range comprises a total of 7 product groups with 38 safety valve types. A variety of materials and sizes from DN 10 to DN 400 – 1/2" to 16", provide safe solutions for almost every industrial application.

High Performance:

Safety valves of this design are generally installed for protection of pressure vessels and industrial systems (gas, steam and liquid applications) by providing rapid discharge of the maximum possible mass flow.

API:

Safety valves according to the API Standard 526; predominantly applicable for the petrochemical and chemical industries.

Compact Performance:

Safety valves for protection of small and medium mass flows for traditional applications like pumps and compressor, but also adapted for cryo applications.

Clean Service:

Safety valves for protection of systems with sanitary and hygienic requirements in the food, beverage and pharmaceutical industries.

Critical Service:

Safety valves partially or fully lined typically with PTFE, suitable for aggressive and corrosive media.

Modulate Action:

Safety valves which are installed for protection of small mass flow predominantly for liquids to assure a minimization of the media losses. Suitable for thermal relief applications.

Best Availability: Other complimentary product series such as supplementary loading systems, change-over valves and bursting discs which complete the LESER product offering.

Please send your request to our Sales Center

To: **LESER GmbH & Co. KG**

Fax: +49 (40) 251 65-500

Date: _____

From: _____

Catalog order:

High Performance [Catalog 1](#)

Flanged Safety Relief Valves

Series 441
Series XXL
Series 444

 pdf Printed version

No. of copies: _____

High Performance [Catalog 2](#)

Flanged Safety Relief Valves

Series 441 Full nozzle
Series 458

 pdf Printed version

No. of copies: _____

Compact Performance

Threaded Safety Relief Valves

Series 437
Series 459

 pdf Printed version

No. of copies: _____

API

Flanged Safety Relief Valves

Series 526

 pdf Printed version

No. of copies: _____

Clean Service

Safety Relief Valves

Series 48X

 pdf Printed version

No. of copies: _____

Critical Service

Safety Relief Valves

Series 447
Series 546

 pdf Printed version

No. of copies: _____

Modulate Action

Flanged Safety Relief Valves

Series 429
Series 433

 pdf Printed version

No. of copies: _____

S & R

Safety Relief Valves
for special or regional
applications

Series L & W
Series TRDF
Series TRDG
Series SBD
Type 612

 pdf Printed version

No. of copies: _____

CD order:

VALVESTAR®

- Ultimate sizing program
- Consideration of all relevant codes and standards
- Comprehensive documentation (sectional drawings, parts lists)
- Different language versions
- Help function

No. of copies: _____

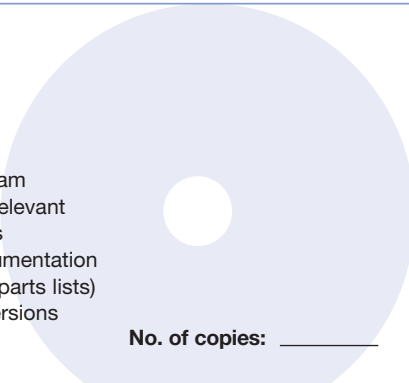

Addressee

Please send the requested copies to:

Name: _____

Company: _____

Address: _____

E-Mail: _____

High Performance Catalog 2
Edition August 2008

LWN 488.01-E / 08.2008 / 5000

LESER

The-Safety-Valve.com

LESER GmbH & Co. KG

20537 Hamburg, Wendenstr. 133-135
20506 Hamburg, P.O. Box 26 16 51

Fon +49 (40) 251 65-100
Fax +49 (40) 251 65-500

E-Mail: sales@leser.com
www.leser.com