

Betriebsanleitung
Ausgabe August 2003

Operating instructions
August 2003 edition

Instructions de service
Edition août 2003

Instrucciones de servicio
Edición agosto 2003

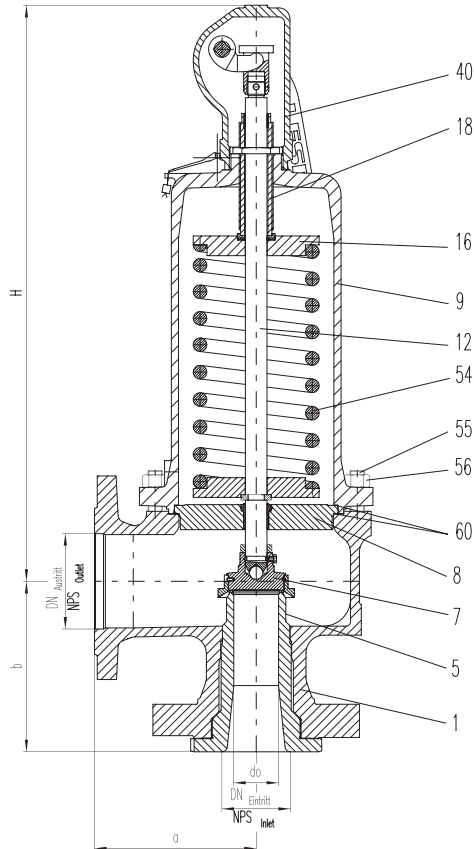

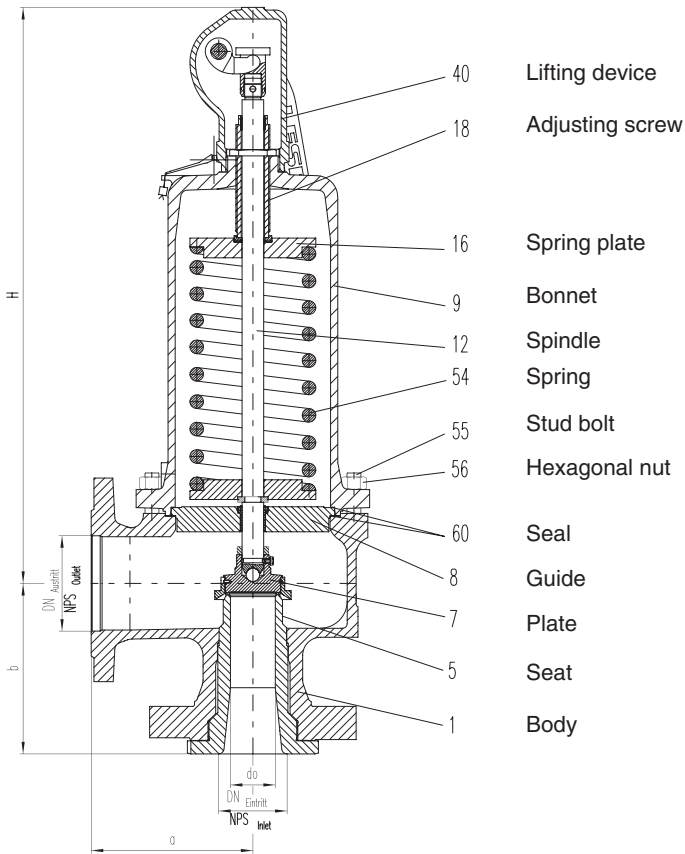

1 Contents

| | | |
|-------|--|----|
| 1 | Contents | 19 |
| 2 | General | 19 |
| 3 | Testing/markings | 19 |
| 4 | Pressure | 20 |
| 5 | Function of a safety valve | 20 |
| 6 | Functional tightness of a safety valve | 21 |
| 7 | Medium | 21 |
| 8 | Temperatures of the medium and ambient temperatures | 22 |
| 9 | Choice of spring | 22 |
| 10 | Safety valves with bellows | 23 |
| 11 | Safety valves with blow-down ring | 23 |
| 12 | Safety valves built into installations | 23 |
| 12.1 | Open bonnet | 23 |
| 12.2 | Regular lifting operation | 23 |
| 12.3 | Forces acting on the safety valve | 23 |
| 12.4 | Connections | 24 |
| 12.5 | Direction of safety valves | 24 |
| 12.6 | Flow-through | 24 |
| 12.7 | Condensation | 24 |
| 12.8 | Transfer of vibrations from the installation | 25 |
| 12.9 | Discharge pipe | 25 |
| 12.10 | Unfavourable environmental conditions | 25 |
| 12.11 | Leaks caused by foreign bodies | 25 |
| 12.12 | Protection during storage and transport | 25 |
| 12.13 | Corrosion protection | 26 |
| 12.14 | Maintenance | 26 |
| 12.15 | Identification of safety valves | 26 |
| 12.16 | Lever safety valves | 26 |
| 13 | Setting instructions for spring loaded safety valves | 26 |
| 13.1 | Lifting device H3 | 26 |
| 13.2 | Lifting device H4 | 26 |
| 13.3 | Spring replacement | 26 |
| 14 | Handling | 27 |
| 15 | Supplementary loading system | 28 |
| 16 | Combined Safety Valve and Bursting Disc | 28 |
| 17 | Unexpected conditions | 29 |
| 18 | Product overview | 29 |
| 19 | Assembly instructions | 29 |
| 20 | Disclaimer | 29 |

2 General

The following general notes refer to directly loaded and controlled safety valves (with supplementary loading system).

To fulfill its function all components of a safety valve are manufactured to great precision. Only this precision allows correct functioning. Safety valves must therefore be handled with care. Failure could endanger people, animals and installations. Even with a correctly functioning safety valve hazards may occur. This has to be taken into account.

The following risks could ensue:

- The safety valve does not work correctly or is dimensioned incorrectly: the pressure equipment bursts. Hazard caused by the bursting itself and by the hot, poisonous and aggressive medium.
- The safety valve operates correctly; medium escapes: there is a risk of hot, poisonous and aggressive medium.
- The safety valves leaks: there is a risk of hot, poisonous and aggressive medium.
- Other dangers caused by handling the safety valves e.g., risk of injury from sharp edges, heavy weight, ...

In order to minimise the risks of these hazards, the operating instructions must be adhered to at all times and given priority over the recommendations below. The operating instructions have been developed by practical experience and from the requirements stipulated in the regulations.

Sets of rules and standards:

- Pressure Vessel and Steam Boiler Ordinance
- TRD 421, 721
- TRB 403, 801 No. 45
- AD 2000-Merkblätter A2 and A4
- DIN EN ISO 4126
- Pressure Equipment Directive 97/23/EC
- ASME Code Section II and VIII
- API 526, 520, 527
- Others.

LESER is in possession of the appropriate product-related certificates to prove that the sets of rules and standards are fulfilled and that safety is therefore guaranteed.

LESER is certified according to DIN EN ISO 9001 (Quality Management System), DIN EN ISO 14001 (Environmental Management System) and Module D of the Pressure Equipment Directive (quality assurance in production). This ensures that all requirements for quality and environment are complied with.

3 Testing/markings

After setting and testing, each safety valve is sealed by LESER or by the expert of an official acceptance organisation at the customer's request (such as TÜV, Germanischer Lloyd, ...).

If the marking of the safety valve is applied on the valve body by means of a marking stamp, the safety valve must not be damaged by such stamping. Deformation of the valve may cause leakage or destruction of the safety valve. Thin-walled valve bodies should not be stamped.

Safety valves have a name plate showing the following data:

- Date of order
- Technical data
- Test pressure
- VdTÜV type test approval number
- CE-marking and identification number of the notified body.

For safety valves without type test approval, only order data and technical data are included.

Further marks required are either moulded into the casting, or, for safety valves with threaded connections, punched in. Safety valves with a heating jacket have a separate name plate for the heating jacket.

If technical changes are made, always check whether the identification has to be adjusted. Modifications on valves or identifications may only be carried out by trained personnel (refer to section 12.14).

4 Pressure

Definitions:

- a) Test pressure: the pressure that the safety valve is set to at LESER's. The outlet side of the safety valve is open to atmospheric pressure.
- b) Set pressure: the predetermined pressure at which a safety valve under operating conditions commences to open.
- c) Opening pressure: the pressure at which the safety valve discharges the certified flowing capacity (this may also be given as the difference from the set pressure in per cent → opening pressure difference).
- d) Reseating pressure: the value of the inlet static pressure at which the disc re-establishes contact with the seat or at which the lift becomes zero.
- e) Operating pressure: the pressure at which the plant operates.
- f) Built-up back pressure: the pressure existing at the outlet of a safety valve caused by flow through the valve and the discharge system.
- g) Superimposed back pressure: the pressure existing at the outlet of a safety valve at the time when the device is required to operate.
- h) Back pressure: the total of built up and superimposed back pressure.

Pressure shall be stated as overpressure [bar g or psig] above atmospheric pressure.

Unless stated otherwise, the pressure specified by the customer is set with atmospheric pressure acting on the outlet side (test pressure = set pressure).

If there is pressure on the outlet side (superimposed back pressure), a force is produced, which acts on the rear side of the disc. This increases the set pressure by exactly the value of this pressure. If the superimposed back pressure is constant, it is possible to adjust the differential pressure by reducing the value of the test pressure by the value of the back pressure (test pressure \neq set pressure).

If there is no superimposed back pressure, the set pressure will drop. The back pressure intended must not be exceeded because then it would also exceed the set pressure.

The maximum pressure that a safety valve may be operated at regardless of the test pressure depends on a number of factors. Among these are:

- Materials
- Medium temperature
- Design pressure
- Flange classes
- Others.

These should be taken into consideration when selecting a safety valve.

The value of the operating pressure must permanently be lower than the reseating pressure difference plus 5%. Otherwise LESER cannot guarantee that the valve will close securely after opening (exception: if the valve is fitted with a supplementary loading system, refer to section 15).

5 Function of a safety valve

A performance certificate is required to ensure that the required mass flow is discharged by the safety valve if necessary.

Pipes leading to the safety valve have to be fitted so that large hydrodynamic losses are prevented. The edges at the pipe inlet should be at least chamfered, but preferably rounded. The notes on dimensioning given in the regulations, standards and manufacturer's information sheets must be adhered to.

Safety valves may only be disabled by means of shut-off valves provided that the pressurised equipment is protected against excessive pressure by other safety devices or that the plant or equipment is shut down altogether.

Safety valves are guaranteed to work perfectly, if the built-up back pressure on the outlet side does not exceed 15% of the test pressure minus the superimposed back pressure (if available).

Built-up and superimposed back pressures may be compensated by an amount not exceeding

35% of the set pressure by using stainless steel bellows specially designed for this, which compensates the force acting on the rear side of the disc. Function and set pressure remain constant. If it is not clear whether the bellows compensate for pressure, LESER should be contacted. The application limits of the bellows for pressure and temperature must not be exceeded (refer to section 10).

If discharge lines are fitted with equipment, which prevents the ingress of rainwater or foreign bodies, such equipment must not obstruct or restrict the outlets of the safety valve.

The blow-off pipe should be dimensioned using the maximum back pressure and the appropriate temperature. It should be installed in a pipe run, which is free from restrictions and turbulences and should not be opposite other branches, to ensure that it does not impair the functioning of the valve or damage it. The capacity and functioning of safety valves must also be ensured in applications, where blow-off systems fulfill several functions.

During blowing-off, reaction forces act on the safety valve itself, the pipes connected to it and the fixed mounts. The size of the reaction force is particularly important for the dimensioning of the fixed mounts.

The following points have to be taken into consideration:

- Static, dynamic or thermal loads exerted by the pipe leading to or from the safety valve must not act on the valve.
- Safety valves must be fixed as specified in the drawing. Omitting or removing mounts can result in damage because this results in excessively large forces or tensions.
- Also refer to section 12.3.

6 Functional tightness of a safety valve

One has to expect a slight leakiness with all safety valves fitted with metal seals. People, environment and installations must not be endangered by the escaping medium.

Safety valves with soft seals seal are much more reliable than those with metal soft seals. LESER offers a range of elastomer materials for different applications. The elastomers must match the medium and its pressure and temperature.

All LESER products are inspected for damage and leaks. In order to prevent damage during transport all products have their flange faces,

sealing lips and pipe threads protected before

being packed for shipment. This protection should be removed before assembly (refer to section 12.12).

Before installing the valve in the plant or pipeline system it should be inspected for damage. Once installed, the valve should be checked for leakage while the plant or pipeline system is operating.

Sealing surfaces are machined with great precision. A tight seal is achieved, for instance, by hardening, tempering, precision-grinding and lapping. This makes safety valves vulnerable to impact damage; they may, for example, develop leaks as a result of vibrations.

The following notes are to be observed:

- During transport, installation and operation safety valves must be protected from vibrations.
- Safety valves must be transported with care, e.g., the lever must never be used as a carrying handle and the safety valve must not be dropped.

The force between the seat and the disc falls as a function of rising operating pressure. Therefore the probability of leaks also rises if the operating pressure is close to the set pressure (refer to section 4). Damaged or contaminated sealing surfaces in particular tend to develop leaks.

7 Medium

Any moving parts have to be protected from abrasive/corrosive media to avoid the risk of jamming, seizing or sticking. This can be done by servicing the valve each time it has opened or by using stainless steel/elastomer bellows. The limits of application for the bellows have to be observed.

The possibility of leaking sealing surfaces caused by abrasive media must be considered. Dangerous media must not be allowed to enter the environment. In case of doubt the safety valve should be replaced after opening.

Soft sealing discs can compensate for minor damage to the seat. In every case the limits of application and medium consistency for the elastomer material have to be observed.

The strength of components (e.g. body, spindle, spring) may be reduced by abrasion. This may lead to leaking or to the bursting of pressure equipment. If abrasive media are used, maintenance intervals should be shortened.

Sealing surfaces must not stick together. This can be prevented by:

- Regular lifting operation (refer to section 12.2)
- Heating or cooling to prevent the seat from sticking
- Other measures which prevent sticking.

Corrosion damage to body parts and inner parts cannot always be spotted easily. Therefore the user must make sure that the medium does not attack or corrode the materials the safety valve is made from. If this possibility cannot be excluded, monitoring and servicing have to be adapted to this situation accordingly. Special materials can be selected on request.

Lubricants based on mineral oils are used as an aid during installation. These fluids can contaminate the medium unless special precautions are taken.

The following points have to be observed:

- Lubricants/auxiliary fluids can reach the medium and contaminate it or cause a chemical reaction.
- Lubricants can be washed out and make the dismantling of the safety valve more difficult.
- Safety valves can be designed as oil and grease-free types. For these types of valves all residues containing mineral oil are removed from the valve surfaces and special lubricants are used.
- Bellows prevent contact between medium and lubricant.

8 Temperatures of the medium and ambient temperatures

Minimum and maximum temperatures are given for LESER safety valves. They always refer to the temperature of the medium, which may simultaneously be the ambient temperature. Therefore, the ambient temperature has to be taken into consideration under extreme climatic conditions such as are found in Scandinavia.

It is necessary to observe the effect of temperatures of the medium on the maximum permitted pressure. If expansion limits drop at higher temperatures or if the medium tends to be brittle at low temperatures, the maximum permitted temperatures must be lowered. Please observe the specifications/regulations in the appropriate sets of rules and the manufacturer's specifications.

If the safety valve is supposed to be thermally insulated, the bonnet and the cooling zones (if there are any) must not be covered to protect the springs from becoming overheated.

To set a safety valve for a particular pressure at a higher ambient temperature, a correction factor should be used to allow for the increased temperature. This eliminates the necessity of adjusting the setting while the medium is at the higher temperature (procedure: Cold differential test pressure according to LESER work standard LWN 001.78).

During the operation of safety valves, medium can freeze, which prevents opening and closing. This can happen if the temperature falls below the freezing point of the medium. In case of media, which congeal at low temperatures, the viscosity may drop significantly. If the medium contains freezing vapours, the risk of icing-up is increased by the expansion of gases as this causes the temperature to fall further. If there is danger of icing, measures must be taken to ensure that the safety valve works correctly.

Contact with hot or dangerously cold safety valve surfaces must be prevented by appropriate protective measures.

9 Choice of spring

The springs used by LESER are designed for defined pressure ranges. The test pressure is always the basis for selecting the spring (refer to section 4). The functioning of the springs is ensured if the spring is designed and used in conformity with the sets of rules.

When dismantling the valves, the springs must not be mixed up as the functioning will be impaired, if the wrong spring is installed. In extreme cases the spring will be fully compressed (the coils touch each other) and the safety valve does not work.

When changing the test pressure the user must check whether the spring/springs can be used at the new pressure. This can be done by using current LESER spring tables (LWN 060.xx). If they are not available please contact LESER. If the spring is not suitable for the new test pressure it must be replaced by a suitable spring. If the test pressure of a safety valve is altered, the whole safety valve and its dimensioning must be checked for suitability.

LESER springs bear clear identification marks. Springs which can no longer be identified or damaged springs must not be used.

Springs must not be reused if it cannot be estimated how many load changes they have been subjected to. This applies in particular to the springs of safety valves which have been exposed to vibrations, as in this case the actual

number of load changes is practically impossible to estimate.

The springs used in LESER safety valves have been matched to the materials used in these valves. In unfavourable cases, there may be factors leading to increased temperature or corrosion that make the following actions necessary:

Temperature effects:

As spring temperatures depend on many external conditions, no general temperature of the medium can be specified as the limit of application. It has to be evaluated in every single case, which of the following measures need to be taken:

- Using spring materials that are heat resistant or tough at subzero temperatures
- Providing the test pressure with a correction factor to compensate for a drop of set pressure at higher temperatures (refer to section 8 for cold adjustment)
- By using highly heat-resistant materials in conjunction with cooling zones, open bonnets and bellows, the effect of the temperature on the spring is reduced.

Corrosion effects:

- Medium may enter into the spring chamber if safety valves do not have bellows. Corrosive/abrasive media reduce the fatigue strength. This should be taken into consideration when selecting, sizing and servicing safety valves.
- Spring materials with increased corrosion resistance may be used (e.g., stainless steel, Hastelloy, ...)

10 Safety valves with bellows

The pressure and temperature application limits of bellows must be complied with.

Defective bellows are recognisable by the medium leaking out of the open bonnet or the vent hole. Hazards from leaking medium must be prevented.

Measures against leaking medium:

- Equipping the valve with an inspection manometer and a drip container.
- In the case of open bonnets, the leaking of the medium cannot be prevented if the bellows are defective. Hazards have to be prevented, (e.g., by a sufficient safety distance, protection equipment or by using only non-hazardous media).

Defective bellows must be replaced immediately in order to ensure the correct function of the safety valve.

Stainless steel bellows for which the number of permitted load changes has been exceeded, or is unknown, must be replaced. As a rule bellows should be replaced whenever the valve is dismantled.

Moisture or dirt must not be allowed to enter the bonnet via the vent hole. Appropriate protective measures (e.g., connections, pipes,...) must be taken.

11 Safety valves with blow-down ring

Safety valves with blow-down ring, like type 526, are always delivered with the blow-down ring in the lowest position. That is, that the blow-down ring is screwed into the nozzle, until the lower stop is reached. The blow-down ring is arrested with a lock screw, which is sealed. The position of the blow-down ring must not be changed.

12 Safety valves built into installations

12.1 Open bonnet

For open bonnets or lever valves, appropriate measures must be taken to avoid contact with movable parts (e.g., the spring) as otherwise there is a danger of jamming. Medium can leak out of the open bonnets or open spindle guides of lever safety valves. The user must ensure that leaking medium cannot cause hazards. A sufficient safety distance has to be observed.

12.2 Regular lifting operation

Safety valves must be vented regularly in order to check their function and to remove residues. They can be opened if at least an operating pressure of $\geq 75\%$ of the set pressure is reached. Exceptions can only be allowed if the functioning is checked regularly in a different way, e.g., by appropriate short maintenance intervals. The valid regulations for the application of safety valves have to be adhered to.

After lifting, the lever must move freely, i.e. the lifting fork in the lifting device must not act on the spindle cap.

12.3 Forces acting on the safety valve

Safety valves must not be subjected to excessive static, dynamic or thermal stresses. These can be caused by:

- Installation under tension (static)
- Reaction forces when blowing off (static)
- Vibrations (dynamic)
- Temperature expansion (thermal)

The following precautions should be taken:

- The system must be able to expand
- Pipe runs must not be fixed in a way that they are under tension.
- The safety valve brackets should be used for attaching the valve securely to the plant.
- Vibration of the safety valve and plant should be prevented.

12.4 Connections

The connections/seals between the safety valve and the plant shall be of sufficient size. They also have to be designed in accordance with the sets of rules to prevent the connection from failing (also refer to sections 4 and 8).

The user is responsible for the correct fitting of seals for pipes leading into the valve and pipes for blowing-off or other connections to the safety valves. Therefore LESER will not accept any liability for these.

For correct installation the user should ensure that the flange sealing surfaces are not damaged during installation.

12.5 Direction of safety valves

Confirmation by the TÜV Nord:

Directly-loaded safety valves are to be installed in accordance with AD 2000-Merkblatt A2 "upright with respect to the flow direction":

In addition AD 2000-Merkblatt A2 requires that "safety valves must correspond to the state-of-the-art and be suitable for the purpose for which they are deployed".

Under the following conditions it is possible to deviate from the upright installation direction, and in our view it is also permissible.

E.g., the safety valves have been granted type approval for non-upright installation and a note to this effect is found in the VdTÜV-Merkblatt.

If adequate experience of installing safety valves in a direction other than upright is available over an extended period, this type of installation is permissible if agreed between operator, manufacturer and the technical inspector, who authorises the installation. If applicable, additional measures may need to be taken with regard to this installation.

Therefore safety valves may, according to the information provided above, be installed in directions other than the one specified in AD 2000-Merkblatt A2.

If the conditions mentioned above have been fulfilled, the following points have to be

observed when installing the valve in a direction other than upright:

- Drainage has to be fitted to drain medium or condensation from components which are important for the function of the valve.
- Servicing procedures should be modified, e.g., the functioning of the drainage system must be ensured.
- LESER must be informed about the type of installation in order to be able to agree to a direction deviating from upright.

12.6 Flow-through

The flow direction must be observed during installation. It can be recognised by the following features:

- Flow direction arrow on the body
- Diagrams in the
 - Complete Catalogue
 - Operating instructions
 - Data sheets and
 - Assembly instructions.

12.7 Condensation

Medium or condensation must be drained from the outlet chamber of the safety valve or such components, which are important to the functioning of the valve (spring, bellows etc.).

The following points should be noted:

- Drainage should always be carried out via the blow-off pipe, which should be installed sloping downwards so that it can drain itself (figure 3).
- Directly downstream of the safety valve there must be no upward bend as in this case correct drainage would not be possible (figure 4).
- The blow-off pipe must be provided with a sufficiently large condensation drainage pipe, which must be attached to the lowest point of the pipe. For pipes larger than nominal diameter 40 mm the drainage pipe must have a nominal diameter of at least 20 mm. (In case of steam applications even larger diameters may be necessary. In such cases the regulations must be observed).
- LESER safety valves are not provided with a drain hole as the drainage must be executed via the blow-off pipe. Exceptions: Certain regulations require drainage holes (e.g., on ships with variable orientation in the water and a pipe slope). Safety valves which are intended for such purposes are equipped with a drainage hole. Such designs are only manufactured if they are specifically ordered.

- It is possible to drill a drain hole later at the place intended for this purpose.
Caution: swarf can cause damage which may lead to leaks or to the failure of safety valves.
- Drainage pipes must be installed sloping downwards; these pipes must have no restrictions such as locally reduced diameters. There must be an unobstructed view of the drain outlet; any risks resulting from leaking medium must be prevented. (e.g., by fitting condensation traps, drip container, filters, etc.)
- Unused drainage holes must be closed.

12.8 Transfer of vibrations from the installation

Any vibrations which might be transferred to the safety valve must be prevented. If this is not possible the safety valve must be decoupled from the installation, e.g., via bellows, pipe bends, ...

Pressure variations or surges in the medium also may lead to dangerous vibrations of the safety valve. This also has to be prevented.

If the transfer of vibrations cannot be prevented, damping systems can be built in, e.g., o-ring dampers.

12.9 Discharge pipe

When a safety valve blows off, in addition to the general hazards from the medium, the following hazards have to be expected (refer to section 2):

- High flow rates
- High temperatures
- Noise emissions

In this context the following points should be noted:

- For steam or gases the blow-off pipe should point upwards in order to allow blowing off without danger.
- For liquids the blow-off pipe should point downwards so that the medium can completely drain out of the blow-off chamber.
- The outlet flange of safety valves or blow-off pipes must be directed so that no danger is caused by the medium blowing off. The following options are available:
 - Blowing off into a container
 - Safety valve and blowing-off pipes without direct access
 - Design with silencer.

12.10 Unfavourable environmental conditions

All LESER safety valves which may corrode are coated with a protective coating during manufacture which protects the safety valve during storage and transport. In corrosive environments a further corrosion protection is required (refer to section 12.13). For extreme conditions, LESER recommends stainless steel safety valves. The supplementary loading system must not be given a protective coating!

External media (e.g., rain water or dirt/dust) must not enter the blowing-off pipe or come in contact with functional components (e.g., guides with open bonnets) have to be avoided. By analogy, the statements made in section 7 apply.

Simple preventive measures are possible:

- Protection of the blow-off chamber from extraneous media and dirt
- Protection of the parts important to operating from external media and dirt.

12.11 Leaks caused by foreign bodies

Foreign bodies must not remain in the installation (e.g., welding beads, sealing material such as hemp tape, PTFE tape, screws, etc.). One option for avoiding foreign bodies in the system is to flush it before commissioning.

If leaks are caused by contamination between the sealing surfaces, the safety valve can be vented to clean the surfaces. If this does not stop the leak, one of the sealing surfaces is probably damaged. In this case the safety valve has to be serviced.

12.12 Protection during storage and transport

All protective devices for transport and handling have to be removed before installing the safety valve.

After installation, the protection for the lever must be removed from the bonnet as otherwise the safety valve cannot be vented. The lever must move freely, i.e. it must be in its initial position and the coupling at the spindle must not be connected to the lever.

In the case of lever safety valves, the wooden wedge, which protects the sealing surfaces from damage during transport, has to be removed.

12.13 Corrosion protection

Moving parts and parts important to the operating of the valve must not be impaired in their motion, e.g. the blowing-off chamber. The spindle guide must not be varnished.

The supplementary loading system must not be coated with protective paint (refer also to section 15).

12.14 Maintenance

Safety valves may only be serviced by skilled staff.

Maintenance intervals cannot be specified by LESER as they depend on many factors:

- Corrosive, aggressive and abrasive media lead to rapid wear and require shorter maintenance intervals
- Frequent operating requires shorter maintenance intervals
- Maintenance intervals have to be agreed between the operator, the inspector and the manufacturer. Inspections must be carried out at the time of the regular external and internal checks of the pressure equipment.

12.15 Identification of safety valves

Before assembling safety valves the documentation must be checked in order to ensure that the correct valve has been selected for the assembly.

12.16 Lever safety valves

The set pressure of lever safety valves is defined by the mass and the position of the loading weights. It is not allowed to change them.

No additional loading weights must be added. The lever must not be used for suspending any parts, e.g. for hanging clothes on.

13 Setting instructions for spring loaded safety valves

The following operating instructions only apply to valves without additional equipment. If there is additional equipment (such as O-ring dampers, proximity switches, bellows, ...) please refer to the corresponding assembly instructions.

13.1 Lifting device H3

1. Remove shaft (40.4).
2. Pull lever (40.6) out to the side.
3. Loosen hexagonal head screw (40.3).
4. Unscrew and remove lever cover (40.1).
5. Loosen lock nut (19).

6. ¹⁾ Turn adjusting screw (18) to the required set pressure.
Pay attention to the admissible pressure range of the spring!
Clockwise turning of adjusting screw increase the spring tension, giving a higher set pressure. Anticlockwise turning of adjusting screw reduces the spring tension, giving a lower set pressure.
7. Reassemble in reverse order and lock at the set pressure.

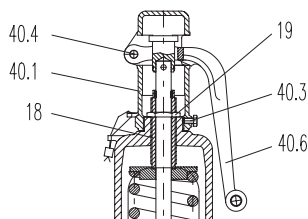

Fig. 1

13.2 Lifting device H4

1. Loosen the spring cover (40.1.1) and simultaneously press the lever (40.1.6) in the direction of the bonnet so that the lifting fork (40.1.5) comes free.
2. Remove the lever cover (40.1.1).
Loosen the lock nut (19).
3. ¹⁾ Turn adjusting screw (18) as described in lifting device H3. Pay attention to the admissible pressure range of the spring!
4. Reassemble in reverse order and lock at the set pressure.

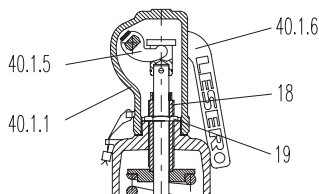

Fig. 2

13.3 Spring replacement

The following items refer to the figures shown on pages 3/40-3/42 of LESER's Complete Catalogue.

1. Loosen the existing lead seal.
2. Press the lever (40.6) towards the middle until it reaches the stop so that the lifting fork (40.5) no longer holds the spindle cap (40.12).

3. Loosen and remove the lever cover (40.1).
4. Loosen the spindle cap (40.12) from the spindle (12), remove the securing ring (40.14) and the pin (40.13).
5. Loosen the lock nut (19) of the adjusting screw (18).
6. ¹⁾ Turn the adjusting screw (18) anticlockwise to remove all spring tension.
7. Remove the hex. nuts (56) from the flange of the bonnet (9).
8. Lift off the bonnet (9).
9. Remove the upper spring plate (16).
10. Lift off the spring (54) and remove lower spring plate (16) and split rings (14).
11. Remove spindle (12) with guide (8) and disc (7).
12. Carefully clean seat (5) and disc (7), and if required body internals.
13. Refit spindle (12) with guide (8) and disc (7).
14. Fit the split rings (14) into spindle groove and retain with the securing ring (59); slip on lower spring plate (16) to locate on split rings (14).
15. Replace spring (54).
16. Slip on the upper spring plate (16) onto the spindle (12).
17. Align adjusting screw (18), and bonnet (9). over the spindle (12) and refit.
18. Fit and tighten the hex. nuts (56).
19. ¹⁾ Load the spring (54) to obtain the required set pressure. Clockwise rotation of adjusting screw (18) increases pressure. Anticlockwise rotation of adjusting screw (18) reduces pressure.
20. Tighten the lock nut (19) onto the adjusting screw (18).
21. Refit and secure spindle cap (40.12) by pin (40.13) and securing ring (40.14).
22. Screw-on the lever cover (40.1).
23. Pull the lever (40.6) towards the middle so that the lifting fork (40.5) is pushed under the spindle cap (40.12).
24. Test spindle will lift correctly by pulling lever.

These instructions are applicable for relief valves, safety valves and safety relief valves.

- 1) **Caution:** During all work the spindle has to be secured against twisting in order to prevent damage to the sealing surfaces.

The following points should be noted:

The pressure setting is wire-locked and sealed against unauthorized alteration. The rules of the TÜV, agreed by the manufacturer, require the fitting of a type test approval plate stating the correct valve data. The manufacturer cannot be held responsible for any changes to set pressure or other alterations after despatch from the factory. Necessary modifications should only be made by authorised distributors of LESER or under the supervision of the TÜV or any other competent inspection authority.

14 Handling

There is a risk of injury from sharp edges and burrs. For this reason all parts have to be handled with caution.

There is a risk from safety valves falling over. They always have to be secured adequately.

During dismantling the spring must not be tensioned. Otherwise there is danger of injury from flying parts. Observe the assembly instructions for the relevant safety valves!

Before dismantling you should always check whether there is, or could be, any medium in the bonnet; also check what the medium is.

There is a great risk of injury, chemical burns or poisoning if there is any remaining medium inside the safety valve.

One should use conventional high quality tools in order to minimise the risks arising from bad quality tools or inadequate tools. Any necessary special tools are indicated in the assembly instructions.

Safety valves may only be dismantled and assembled by skilled staff.

The training can be carried out:

- In the workshop by experienced staff
- At LESER training seminars
- By means of LESER documentation, e.g., videos, operating instructions, catalogues, assembly instructions

The maintenance staff must be informed about the risks during dismantling and installing the safety valves.

Contamination and damage to the safety valve must be avoided. Suitable cartons, protective covers for the flanges, wrapping foil, shipping palletes etc. have to be used. The packaging must be completely removed before installation as otherwise the function of the safety valve cannot be guaranteed.

Safety valves have to be handled with care as otherwise the vulnerable sealing surfaces can be damaged or the safety valve might even be rendered useless.

Safety valves must be stored in a dry place. The optimum storage temperature is 5 °C to 40 °C. For o-ring discs temperatures below freezing should be avoided, if possible. The temperature resistance, in particular of the o-ring materials, has to be taken into account. Upper limit for storage: 50 °C
Lower limit for storage: -10 °C

15 Supplementary loading system

Even if the external energy supply (compressed air) fails, the direct-loaded safety valve is still fully functional. In this case the function is equivalent to the LESER standard safety valve without supplementary loading system.

The compressed air filter must be serviced at regular intervals as specified in the maintenance instructions.

The installation should contain an air dryer. The compressed air should have a dew-point of minimum +2 °C.

The maximum pressure of the air supply is 10 bar, the minimum pressure is 3.5 bar. If the pressure rises above or falls below the specified interval, this may lead to temporary or permanent failure of the supplementary loading system. As a result the safety valve does not function or it will work as a standard valve without the supplementary loading system.

The supplementary loading system should be serviced and checked at least once a year by specially trained staff. For this essential work LESER offers a maintenance service which may be incorporated in a service agreement. Training and experience with handling the supplementary loading system in combination with the safety valves are essential.

The supplementary loading system has to be fitted in accordance with the rules and standards and the specifications distributed by LESER. If serviced correctly, failures due to contamination of the pressure and control lines can be excluded.

The control unit is to be protected from contamination. It has to be ensured that it is always closed. For special applications LESER offers an encapsulated box sealing the control unit.

The actuator on the safety valve itself as well as sliding parts inside an open bonnet must be protected from contamination. Otherwise there is the danger of jamming.

Temperatures:

The controls and actuators are designed for applications between 2 °C and 60 °C.

- At temperatures above 60 °C the compressed air connections must be as long as possible and equipped with a water seal.
- The control unit and actuators have to be positioned in a way that their temperature will not exceed 60 °C.
- At a temperature below 2 °C there may be danger of icing-up, therefore it may be

necessary to heat control unit, control lines and tapping lines.

The supplementary loading system is connected to the safety valve via a coupling. The coupling must not be blocked by objects. It is neither necessary nor permitted to apply a protective coating to the actuator.

The pressure tapping lines must not be shut off. If there are shut-off devices they have to be designed in such a way that they cannot be closed, e.g., by means of locking bars or seals.

LESER control units are equipped with a shut-off device for maintenance purposes. They are secured against shutting-off by means of a locking bar. This locking bar must not be removed.

The pressure switches are wire-locked and sealed. This seal indicates that the setting has not been changed. It is not permitted to manipulate the pressure switches (e.g., by opening the seal and modifying the adjustment or by opening the switching contacts, ...)!

If a test gag is used during pressure testing of the installation it must be removed after the test.

16 Combined Safety Valve and Bursting Disc

The type test approval of the combination of bursting discs of a certain manufacturer with LESER safety valve ensures that both the functional and performance requirements are met. If you require information on the tested combinations, please contact LESER.

Combinations of LESER safety valves and bursting discs of other manufacturers are permissible, if they meet the safety requirements. This shall be certified for each individual case.

The following points should be noted in particular:

- Operating instructions for the bursting disc.
- Safety valves must not lose their function by placing the upstream bursting disc.
- The space between the rear side of the bursting disc and safety valve inlet should be monitored.
- The bursting disc should be designed in a way that it cannot be installed incorrectly.
- The bursting disc has to open free of fragments. Bursting disc components must not enter the inlet connecting pieces of the safety valve thus impairing the function.

- Sets of rules with reference to bursting discs (AD 2000-Merkblatt A1, ASME, ...)

17 Unexpected conditions

Not all errors can be prevented entirely.

However, their consequences must be estimated and reduced by:

- A risk analysis for the complete installation
- An estimate of the risk and potential damage
- Instructions about the measures to be taken in the case of malfunctioning
- Staff training at the manufacturer's and at the operator's
- Protective measures for people and for the environment.

18 Product overview

For the product overview please refer to the "Declaration of conformity".

19 Assembly instructions

In addition to the Operating Instructions there is a number of type-specific assembly instructions, which are listed in the "Request form LESER Assembly Instructions".

In detail the type-specific assembly instructions have to be observed.

20 Disclaimer

The manufacturer reserves the right to make technical changes or improvements at any time.

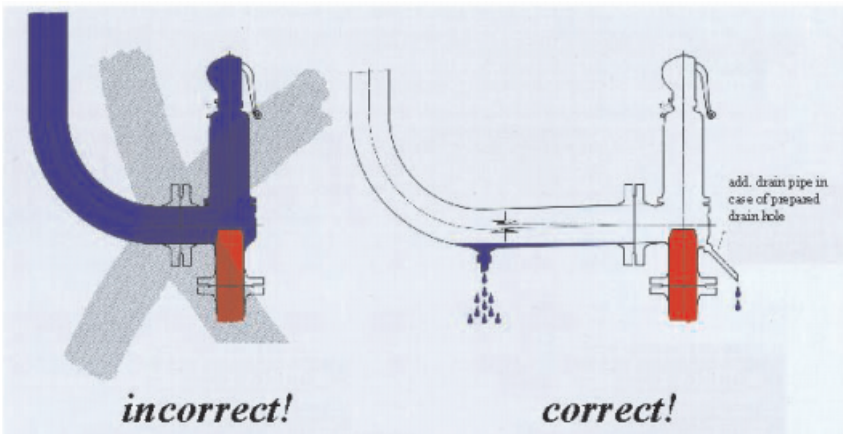

Fig. 4

Fig. 4

Declaration of Conformity/Konformitätserklärung according to Pressure Equipment Directive 97/23/EC nach Druckgeräterichtlinie 97/23/EG



LESER GmbH & Co. KG
Wendenstr. 133-135
20537 Hamburg/Germany

Name and address of the manufacturer/Name und Anschrift des Herstellers

| Type* | Nominal pipe size/ Nennweite | | EC-type examination No./ EG-Bauteilprüfnummer | Type* | Nominal pipe size/ Nennweite | | EC-type examination No./ EG-Bauteilprüfnummer |
|----------|---------------------------------|----------|--|--------------------|---------------------------------|----------|--|
| | NPS | DN | | | NPS | DN | |
| 411 | ¾" - 6" | 20 - 150 | 07 202 0111Z0008/0/02 | 532, 534 | ½" - 6" | 20 - 150 | 07 202 0111Z0008/0/15 |
| 421 | 1" - 4" | 25 - 100 | 07 202 0111Z0008/0/03 | 538 | ½" | 10 | 07 202 0111Z0008/0/16 |
| 424 | — | 25 - 200 | 07 202 0111Z0008/0/04 | 539 | ½" - ¾" | 10 - 15 | 07 202 0111Z0008/0/17 |
| 427, 429 | ½" - 6" | 15 - 150 | 07 202 0111Z0008/0/05 | 543, 544 | 2" - 4" | 50 - 100 | 07 202 0111Z0008/0/18 |
| 431, 433 | ½" - 6" | 15 - 150 | 07 202 0111Z0008/0/06 | 546 | 1" - 4" | 25 - 100 | 07 202 0111Z0008/0/19 |
| 440 | — | 20 - 150 | 07 202 0111Z0008/0/07 | 483, 484, 485 | 1", 2" | 25, 40 | 07 202 0111Z0008/0/20 |
| 441, 442 | ¾" - 16" | 20 - 400 | 07 202 0111Z0008/0/08 | 437, 438, 439, 481 | ½", ¾", 1" | — | 07 202 0111Z0008/0/21-1 |
| 447 | 1" - 4" | 25 - 100 | 07 202 0111Z0008/0/09 | 700 | — | — | 07 202 0111Z0008/0/22 |
| 448 | 1" - 4" | 25 - 100 | 07 202 0111Z0008/0/10 | 522 | 2" - 4" | 50 - 100 | 07 202 0111Z0008/0/23 |
| 455, 456 | 1" - 4" | 25 - 100 | 07 202 0111Z0008/0/11 | 450/460 | ¾" - 1" | 15 - 20 | 07 202 0111Z0008/0/24 |
| 457, 458 | 1" - 6" | 25 - 150 | 07 202 0111Z0008/0/12 | 488 | 1" - 4" | 25 - 100 | 07 202 0111Z0008/0/25 |
| 459 | ½" - 1" | 10 - 20 | 07 202 0111Z0008/0/13 | 526 | 1" - 8" | 25 - 200 | 07 202 0111Z0012/2/26 |
| 462 | ¾" - 1" | 15 - 20 | 07 202 0111Z0008/0/14 | 486, 586 | 1" - 3" | 25 - 80 | |

Description of the pressure equipment/Beschreibung des Druckgerätes

** See name plate/siehe Bauteilprüfschild*

Kategorie IV/Category IV

Applied category according to article 3 and annex II/Angewandte Kategorie nach Artikel 3 und Anhang II

| Module/Modul | Conformity assessment procedures/ Konformitätsbewertungsverfahren | Certificate number/ Bescheinigungsnummer |
|--------------|--|---|
| B | EC type-examination/EG-Baumusterprüfung | See table/siehe Tabelle |
| D/D1 | Production quality assurance/Qualitätssicherung Produktion | 07 202 0111Z0008/0/01-2 |

Conformity assessment procedures according to article 10/Angewandte Konformitätsbewertungsverfahren nach Artikel 10

TÜV CERT - Zertifizierungsstelle für Druckgeräte der TÜV NORD GRUPPE
Identification number 0045, Große Bahnstr. 31, 22525 Hamburg/Germany

Name and address of the notified body (monitoring a.m. conformity assessment procedures)

Name und Anschrift der benannten Stelle (Zertifizierung/Überwachung nach o.g. Modulen)

The signing manufacturer confirms by this declaration that the design, manufacturing and inspection of this pressure equipment meet the requirements of the Pressure Equipment Directive.
Der unterzeichnende Hersteller bescheinigt hiermit, dass Konstruktion, Herstellung und Prüfung dieses Druckgerätes den Anforderungen der Druckgeräterichtlinie entsprechen.

At the moment no harmonized standards available/zurzeit keine harmonisierten Normen verfügbar

Applied harmonized standards/Angewandte harmonisierte Normen

DIN EN ISO 4126-1, AD 2000-Merkblatt A2, AD 2000-Merkblatt A4, TRB 403, TRD 421, TRD 721, DIN 3320, DIN 3840, VdTÜV SV 100
Other applied standards or technical rules/Andere angewandte Normen oder technische Spezifikationen

LESER GmbH & Co. KG
Wendenstr. 133-135, 20537 Hamburg

01.08.2003

Date

Manufacturer stamp

Authorized subscriber

LWN 248.13 -08/03

LESER GmbH & Co. KG
Hamburg HRA 82 424
GF - BoD Joachim Klaus (E-Mail: seidel.m@leser.com)
Martin Leser (E-Mail: werner.c@leser.com)

Hausanschrift - Home address
20537 Hamburg, Wendenstr. 133-135
Postanschrift - Postal address
20506 Hamburg, P.O. Box 26 16 51

Fon +49 (40) 251 65-100
Fax +49 (40) 251 65-500
E-Mail sales@leser.com
www.leser.com

USD-# - VAT-Reg
DE 118840936
Steuern. - Tax No.
22/320/00123

Bank Vereins- und Westbank AG, Hamburg
BLZ 200 300 00, Konto - Account 3203171
SWIFT: VUWB DE HH
IBAN: DE64 2003 0000 0003 2031 71

Declaration of Conformity/Konformitätserklärung according to Pressure Equipment Directive 97/23/EC nach Druckgeräterichtlinie 97/23/EG

LESER GmbH & Co. KG
Wendenstr. 133-135
20537 Hamburg/Germany

Name and address of the manufacturer/Name und Anschrift des Herstellers



| Type* | Material/ Werkstoff | Nominal pipe size/ Nenn- weite | Description of pressure equipment/ Benennung des Druckgerätes | Applied category in acc. to article 3 and annex II/ Angewandte Kategorie nach Artikel 3 und Anhang II | Conformity assessment procedures according to article 10/ Angewandte Konformitäts- bewertungsverfahren nach Artikel 10 | CE- marking/ CE-Kenn- zeichnung |
|-------|--------------------------------|--|---|--|--|--|
| 310 | 1.0619 GS-C 25 GP 240 GH | DN 25 | Change-over Valve Wechselventil | Art. 3 Par. 3 Art. 3 Abs. 3 | Not necessary Nicht erforderlich | No Nein |
| | 1.4408 X5 CrNiMo19-11-2 | DN 40, DN 50 | | Cat. II Kat. II | D1 | Yes Ja |

Description of the pressure equipment/Beschreibung des Druckgerätes

** See name plate/siehe Bauteilprüfschild*

| Module/Modul | Conformity assessment procedures/ Konformitätsbewertungsverfahren | Certificate number/ Bescheinigungsnummer |
|--------------|--|---|
| D1 | Production quality assurance/Qualitätssicherung Produktion | 07 202 0111Z00080/01-2 |

Certificate number of module D1/Zertifikatsnummer Modul D1

TÜV CERT - Zertifizierungsstelle für Druckgeräte der TÜV NORD GRUPPE
Identification number: 0045, Große Bahnstr. 31, 22525 Hamburg/Germany

*Name and address of the notified body (monitoring a.m. conformity assessment procedures)
Name und Anschrift der benannten Stelle (Zertifizierung/Überwachung nach o.g. Modulen)*

The signing manufacturer confirms by this declaration that the design, manufacturing and inspection of this pressure equipment meet the requirements of the Pressure Equipment Directive.
Der unterzeichnende Hersteller bescheinigt hiermit, dass Konstruktion, Herstellung und Prüfung dieses Druckgerätes den Anforderungen der Druckgeräterichtlinie entsprechen.

DIN EN 1503-1, DIN EN 10213-1, DIN EN 10213-2, DIN EN 10213-4

Applied harmonized standards/Angewandte harmonisierte Normen

DIN 3840

Other applied standards or technical rules/Andere angewandte Normen oder technische Spezifikationen

01.08.2003

Date

LESER GmbH & Co. KG
Wendenstr. 133-135, 20537 Hamburg

Manufacturer stamp

Authorized subscriber

LESER GmbH & Co. KG
Hamburg HRA 82 424
GF · BoD Joachim Klaus (E-Mail: seidel.m@leser.com)
Martin Leser (E-Mail: werner.c@leser.com)

Hausanschrift · Home address
20537 Hamburg, Wendenstr. 133-135
Postanschrift · Postal address
20506 Hamburg, P.O. Box 26 16 51

Fon +49 (40) 251 65-100
Fax +49 (40) 251 65-500
E-Mail sales@leser.com
www.leser.com

UST-ID VAT-Reg
DE 118840936
Steuernr. · Tax No.
22/320/00123

Bank Vereins- und Westbank AG, Hamburg
BLZ 200 300 00, Konto - Account 3203171
SWIFT: VUWB DE HH
IBAN: DE64 2003 0000 0003 2031 71

Declaration of Conformity/Konformitätserklärung according to Pressure Equipment Directive 97/23/EC nach Druckgeräterichtlinie 97/23/EG



LESER GmbH & Co. KG
Wendenstr. 133-135
20537 Hamburg/Germany

Name and address of the manufacturer/Name und Anschrift des Herstellers

| Type* | Material/ Werkstoff | Nominal pipe size/ Nenn- weite DN | Description of pressure equipment/ Benennung des Druckgerätes | Applied category in acc. to article 3 and annex II/ Angewandte Kategorie nach Artikel 3 und Anhang II | Conformity assessment procedures according to article 10/ Angewandte Konformitäts- bewertungsverfahren nach Artikel 10 | CE- marking/ CE-Kenn- zeichnung |
|-------|---------------------------------|---|---|--|---|--|
| 612 | 0.6025 GG-25/ GJL-250 | 15-50 | Pressure Reducer Druckminderer | Art. 3 Par. 3 Art. 3 Abs. 3 | Not necessary Nicht erforderlich | No Nein |
| | | 65-100 | | Kat. I Cat. I | A | Yes Ja |
| | 1.0619 GS-C 25/ GP 240 GH | 15-32 | | Art. 3 Par. 3 Art. 3 Abs. 3 | Not necessary Nicht erforderlich | No Nein |
| | | 40-100 | | Kat. I Cat. I | A | Yes Ja |

Description of the pressure equipment/Beschreibung des Druckgerätes

** See name plate/siehe Bauteilprüfschild*

| Module/Modul | Conformity assessment procedures/ Konformitätsbewertungsverfahren | Certificate number/ Bescheinigungsnummer |
|--------------|--|---|
| D1 | Production quality assurance/Qualitätssicherung Produktion | 07 202 0111Z0008/0/01-2 |

Certificate number of module D1/Zertifikatsnummer Modul D1

TÜV CERT - Zertifizierungsstelle für Druckgeräte der TÜV NORD GRUPPE
Identification number: 0045, Große Bahnstr. 31, 22525 Hamburg/Germany

*Name and address of the notified body (monitoring a.m. conformity assessment procedures)
Name und Anschrift der benannten Stelle (Zertifizierung/Überwachung nach o.g. Modulen)*

The signing manufacturer confirms by this declaration that the design, manufacturing and inspection of this pressure equipment meet the requirements of the Pressure Equipment Directive.
Der unterzeichnende Hersteller bescheinigt hiermit, dass Konstruktion, Herstellung und Prüfung dieses Druckgerätes den Anforderungen der Druckgeräterichtlinie entsprechen.

DIN EN 1503-1, DIN EN 1503-3, DIN EN 10213-1, DIN EN 10213-2

Applied harmonized standards/Angewandte harmonisierte Normen

DIN 3840, DIN 1691, DIN EN 1561

Other applied standards or technical rules/Andere angewandte Normen oder technische Spezifikationen

LESER GmbH & Co. KG
Wendenstr. 133-135, 20537 Hamburg

01.08.2003

Date

Manufacturer stamp

Authorized subscriber

LWN 248.14 -08/03

LESER GmbH & Co. KG
Hamburg HRA 82 424

GF · BoD Joachim Klaus (E-Mail: seidel.m@leser.com)
Martin Leser (E-Mail: werner.c@leser.com)

Hausanschrift · Home address
20537 Hamburg, Wendenstr. 133-135
Postanschrift · Postal address
20506 Hamburg, P.O. Box 26 16 51

Fon +49 (40) 251 65-100
Fax +49 (40) 251 65-500
E-Mail sales@leser.com
www.leser.com

USt-ID · VAT-Reg
DE 118840936
Steuernr. · Tax No.
22/320/00123

Bank Vereins- und Westbank AG, Hamburg
BLZ 200 300 00, Konto · Account 3203171
SWIFT: VUWB DE HH
IBAN: DE64 2003 0000 0003 2031 71

Anforderungsformular LESER-Betriebsanleitung pdf-Dateien
Request form LESER Operating Instructions pdf files

- | | | | |
|---|---|---|---|
| <input type="checkbox"/> Italienisch <i>Italian</i> | <input type="checkbox"/> Russisch <i>Russian</i> | <input type="checkbox"/> Schwedisch <i>Swedish</i> | <input type="checkbox"/> Niederländisch <i>Dutch</i> |
| <input type="checkbox"/> Portugiesisch <i>Portuguese</i> | <input type="checkbox"/> Polnisch <i>Polish</i> | <input type="checkbox"/> Slowakisch <i>Slovakian</i> | |

Anforderungsformular LESER-Montageanweisungen pdf-Dateien
Request form LESER Assembly Instructions pdf files

| Deutsch <i>German</i> | Englisch <i>English</i> | Italienisch <i>Italian</i> | Montageanweisung <i>Assembly Instructions</i> | LWN-Nr. <i>LWN-No.</i> |
|--------------------------|----------------------------|-------------------------------|--|---------------------------|
| <input type="checkbox"/> | <input type="checkbox"/> | <input type="checkbox"/> | Type 437 <i>Type 437</i> | 324.12 |
| <input type="checkbox"/> | <input type="checkbox"/> | | Type 438 und 481 <i>Type 438 and 481</i> | 324.11 |
| <input type="checkbox"/> | <input type="checkbox"/> | | Type 483, 484, 485, 488 <i>Type 483, 484, 485, 488</i> | 324.06 |
| <input type="checkbox"/> | <input type="checkbox"/> | | Hubbegrenzung durch Stellschraube <i>Lift stopper</i> | 324.01 |
| <input type="checkbox"/> | <input type="checkbox"/> | | O-Ring-Dämpfer <i>O-Ring damper</i> | 324.02 |
| <input type="checkbox"/> | <input type="checkbox"/> | | Mechanische Anlüftung H4 Gr. 0-1 <i>Mechanical lifting device H4 size 0-1</i> | 324.05 |
| <input type="checkbox"/> | <input type="checkbox"/> | | Pneumatische Anlüftung H8 Gr. 0-3 <i>Pneumatic lifting device H8 size 0-3</i> | 324.07 |
| <input type="checkbox"/> | <input type="checkbox"/> | | O-Ring-Dämpfer für Type 485 <i>O-Ring damper for type 485</i> | 324.08 |
| <input type="checkbox"/> | <input type="checkbox"/> | | Blockierschraube <i>Test gag</i> | 324.04 |
| <input type="checkbox"/> | <input type="checkbox"/> | | Berstscheiben <i>Bursting discs</i> | 324.16 |
| <input type="checkbox"/> | <input type="checkbox"/> | | Anzugsdrehmoment <i>Tightening torque</i> | 322.04 |
| <input type="checkbox"/> | <input type="checkbox"/> | | Anzugsdrehmoment <i>Tightening torque</i> | 322.04 |
| <input type="checkbox"/> | <input type="checkbox"/> | | Näherungsinitiator <i>Proximity switch</i> | 323.02 |
| <input type="checkbox"/> | <input type="checkbox"/> | | O-Ring-Teller <i>O-ring discs</i> | 323.03 |
| <input type="checkbox"/> | <input type="checkbox"/> | | Lösbare Hubglocke <i>Removable lifting aid</i> | 326.06 |

Please send your request to Ms. Gönülacar: goenuelacar.s@leser.com.



LWN 480.1 – 480.28 08/2003 – 10.000

LESER GmbH & Co. KG, Hamburg

20537 Hamburg, Wendenstr. 133-135
20506 Hamburg, Postfach/P.O.Box 26 16 51
www.leser.com

Fon +49 (40) 251 65-100
Fax +49 (40) 251 65-500
E-Mail: sales@leser.com