

LESER at a glance

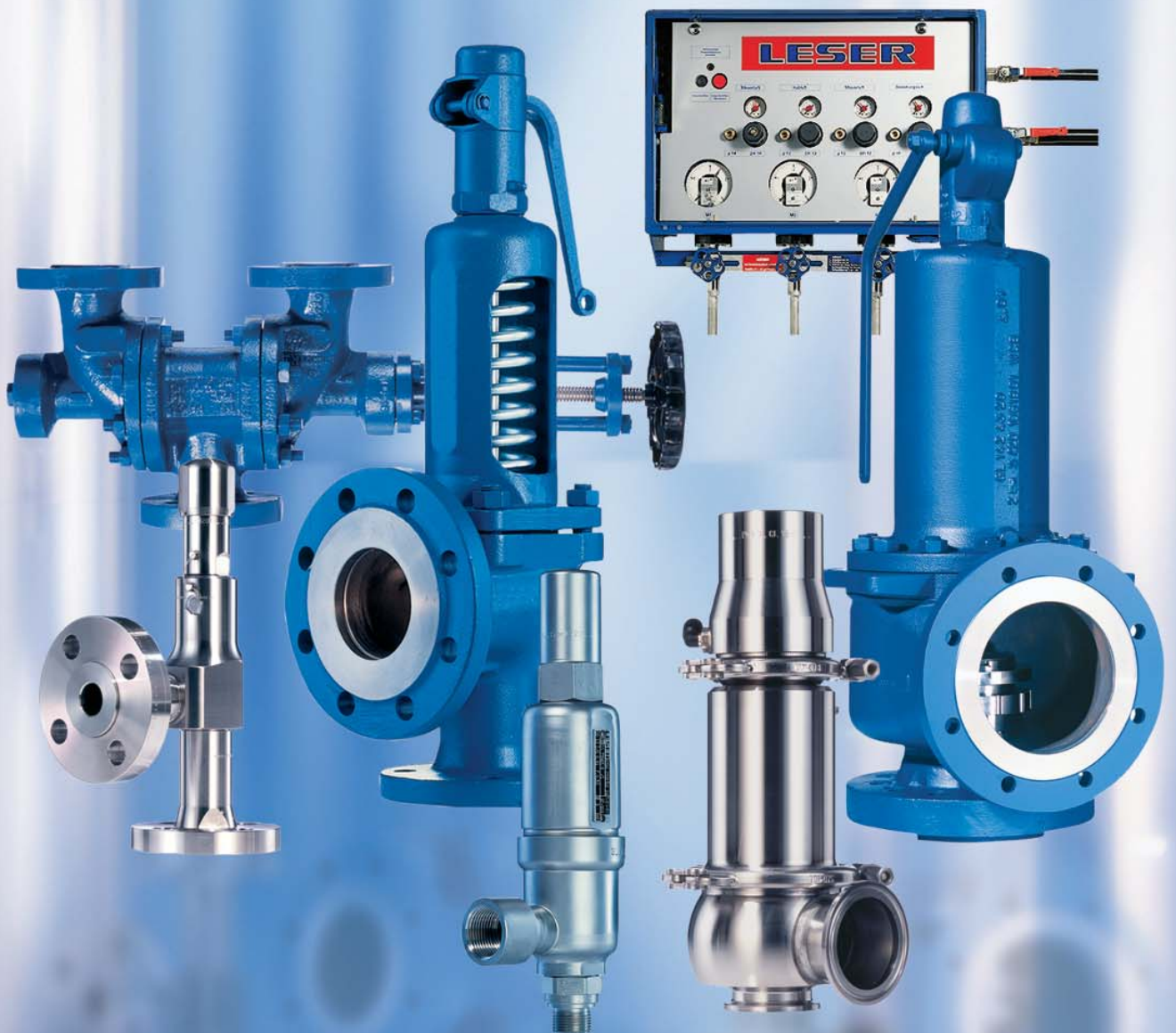

LESER

The-Safety-Valve.com



API

Series 526

Applications

- Refineries
- Chemical industry
- Petrochemical industry
- Oil and gas – Onshore and Offshore

Product features

- Valve sizes 1" through 8", Orifice D through T
- Materials: WCB, CF8M, WC6, LCB, specials
- Design according to API 526
- Great variety of options and flanged connections available
- Standard metal sealing
- Single trim for steam, gas and liquid

Compact Performance

Series 437, 459

Applications

- Thermal relief
- Air/gas compressors and pumps
- Technical gases and CO₂ plants
- LPG/LNG terminals, carriers etc
- Chemical equipment and piping
- Cryogenic systems and oxygen applications

Product features

- Great variety of threaded or flanged connections
- Valve sizes from 3/8" through 1 1/2"
- Broad set pressure range up to 800 bar / 11600 psig
- Wide range of materials and options to fit any application
- Stellite metal sealing for longer product life
- Soft seat for superior tightness
- Single trim for steam, gas and liquid



High Performance

Series 441, XXL, 444, 441 Full nozzle, 458

Applications

- Heat exchanger
- Chemical equipment & piping
- General steam installations
- All industrial applications independent from the medium
- Air/gas compressors & pumps

Product features

- Great variety of types, materials and options to fit any application
- Valve sizes from DN 20 through DN 400, 1" through 16"
- Flange connections according to DIN EN, ASME and other
- High capacity compared to the API requirements
- Standard metal sealing
- Single trim for steam, gas and liquid

Clean Service



Series 48x

Applications

- Pharmaceutical industry
- Breweries
- Food and beverage industry
- Cosmetic industry

Product features

- Valve sizes DN 25 through DN 100, 1" through 4"
- Great variety of aseptic connections (e.g. clamps, flanges) and option to fit any application
- Materials: Stainless steel 316L, 1.4404, 1.4435 and specials
- Minimum dead leg design and flush-mounting capability
- Soft seat (FDA compliant elastomers) for superior tightness
- Gap and crevice free design of internals
- Elastomer bellows for protection of the hard to clean parts
- Surface grades according to ASME BPE-2002
- Single trim for steam, gas and liquid

Critical Service

Series 447,

TEFLON®-lined

546, 449

Applications

- Corrosive or aggressive chemicals
- Chemical equipment and piping
- Chlorine manufacture and processing
- Reducing acids (e.g. hydrochloric acid, acetic acid)
- Alkalis or caustic service
- MDI systems

Product features

- Valve sizes DN 25 through DN 100, 1" through 4"
- Flange connections according to DIN EN, ASME and other
- Body is resistant against most chemicals by special coating
- PTFE lining or special metals
- A PTFE or metal bellows protects the bonnet area against product influences
- Smooth inside surface avoid adherence of corrosive matters
- Single trim for gas and liquid

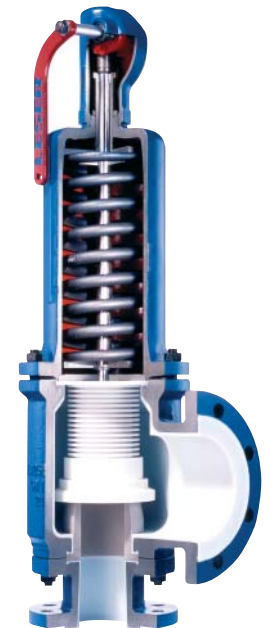

Modulate Action



Series 429, 433

Applications

- Thermal expansion
- Reciprocating compressors and plants with pulsating operating pressure
- Heat transfer oil systems
- Protection of liquids
- Overflow operation
- Mechanical engineering (OEM)

Product features

- Great variety materials and options to fit any application
- Valve sizes DN 15 through DN 150, 1/2" through 6"
- Flange connections according to DIN EN, ASME and other.
- Low overall height and low weight
- One connection size for inlet and outlets
- Single trim for gas and liquid

Best Availability

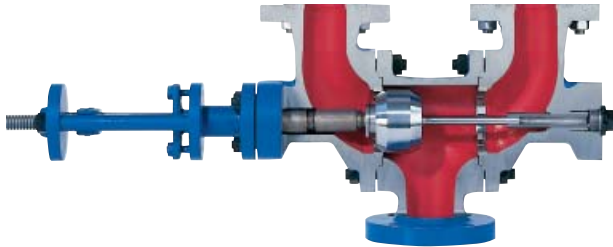

Series 3100 Change-over valves

Change-over valves will be used if a plant shutdown is impossible or undesirable for process engineering or commercial reasons. With change-over valves it is possible to switch over between parallel safety valves without interrupting operation, so as, for example, to perform maintenance work.

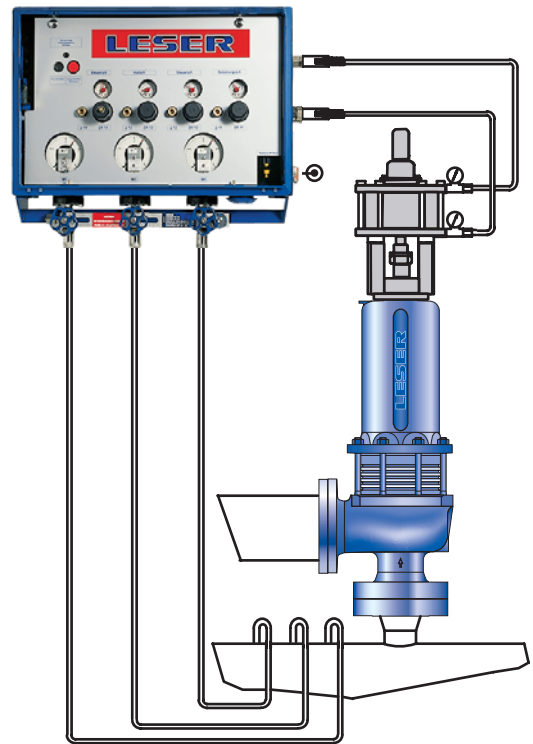

Series 7000 Supplementary loading system

The supplementary loading system allows the system operating pressure to be increased to just below the set pressure of the safety valve. The functional leak tightness of the additionally loaded safety valve is ensured up to the set pressure (anti-simmer device).

Series 3500 Safety valve and bursting disc in combination

The safety valve/bursting disc combination is used, where environmentally harmful, toxic or expensive media or media with a propensity to adhere are protected, and at the same time the highest demands are placed on freedom from leakage.

S&R

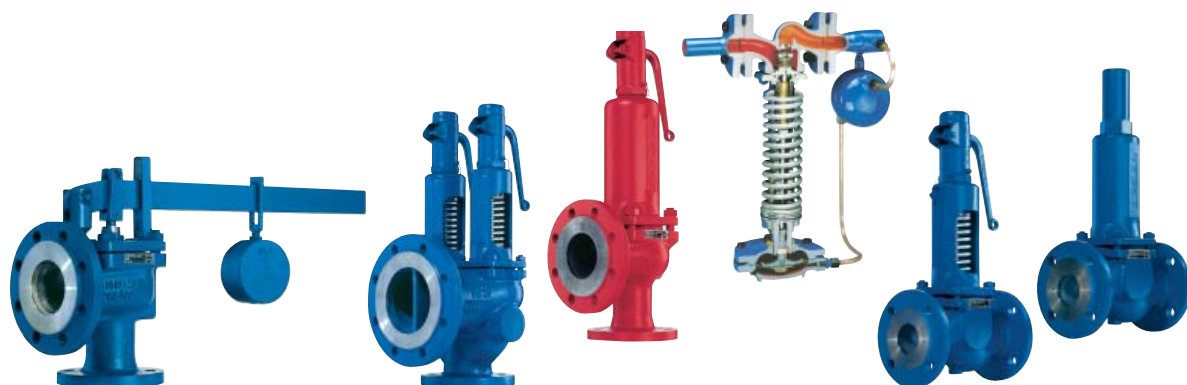

How to find the right Product Group

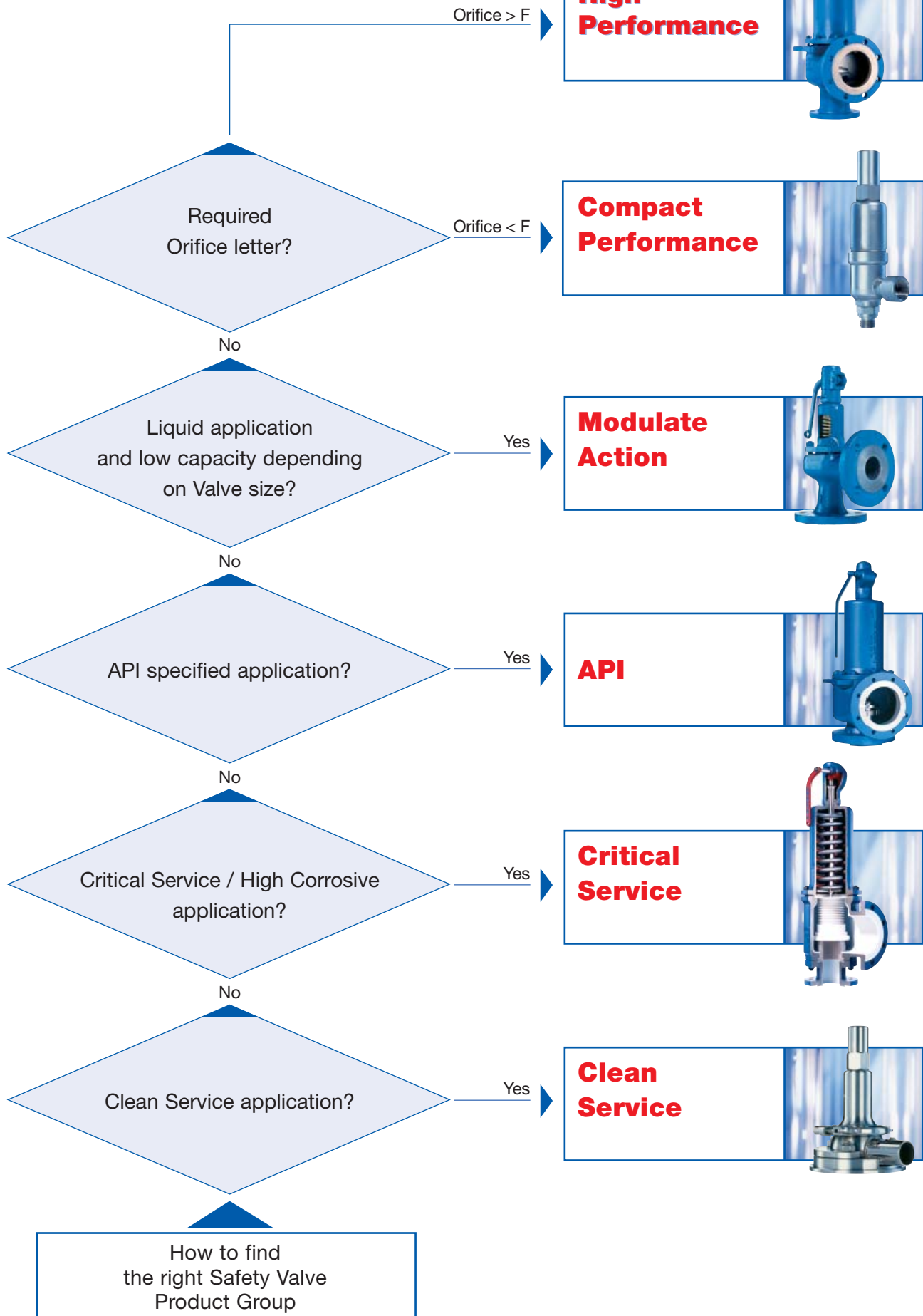

- 1 Simplified design with few parts for built-in safety.
- 2 One piece spindle reduces friction and allows better alignment.
- 3 Long spring allows large pressure range for each spring and leads to a very low number of different springs.
- 4 Self-draining body avoids residues and reduces corrosion.

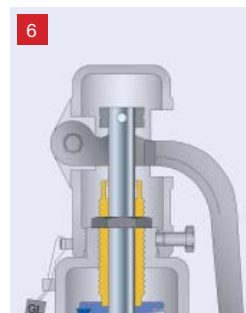
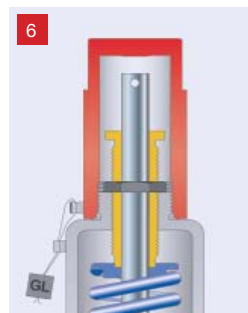
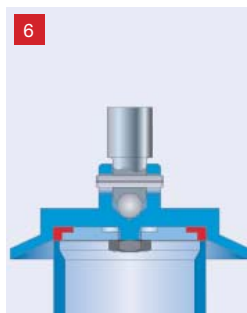
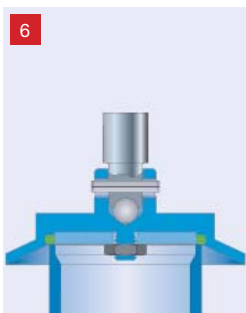
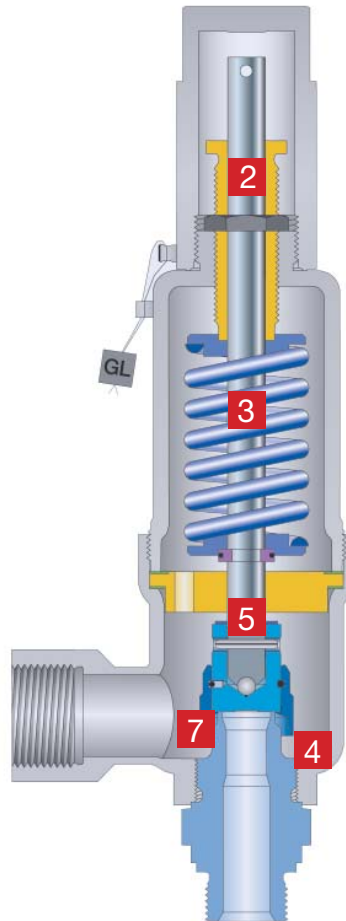
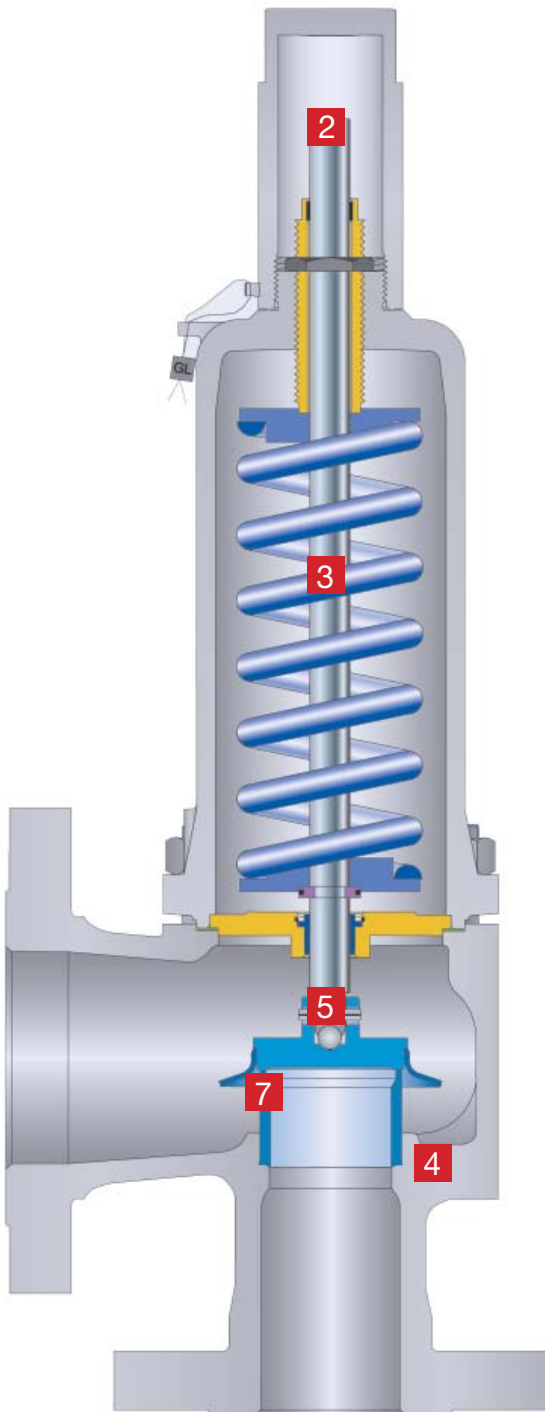

- 5 Single trim for steam, gas and liquids for fewer spare valves in your stock.
- 6 Many options available to adapt the safety valve to specific plant conditions.
- 7 Stellite or hardened metal sealing for longer product life.
- 8 Set pressure is defined as “initial audible discharge” (not “pop”) that allows a lower gap between set pressure and operating pressure and avoids damages during valve popping when valve is set.
- 9 Integral cast support brackets for excellent handling of the valves (API and heavy safety valves)

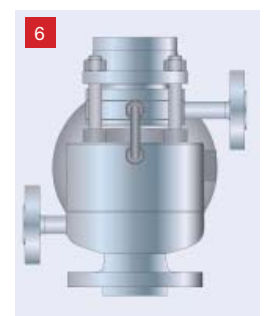
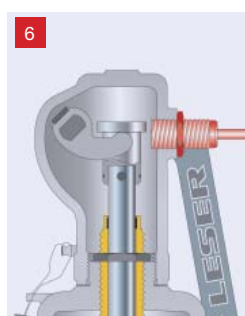
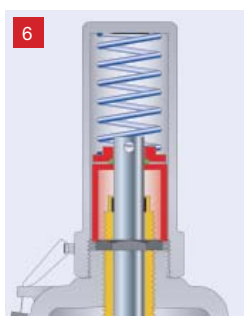
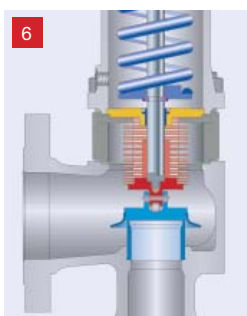
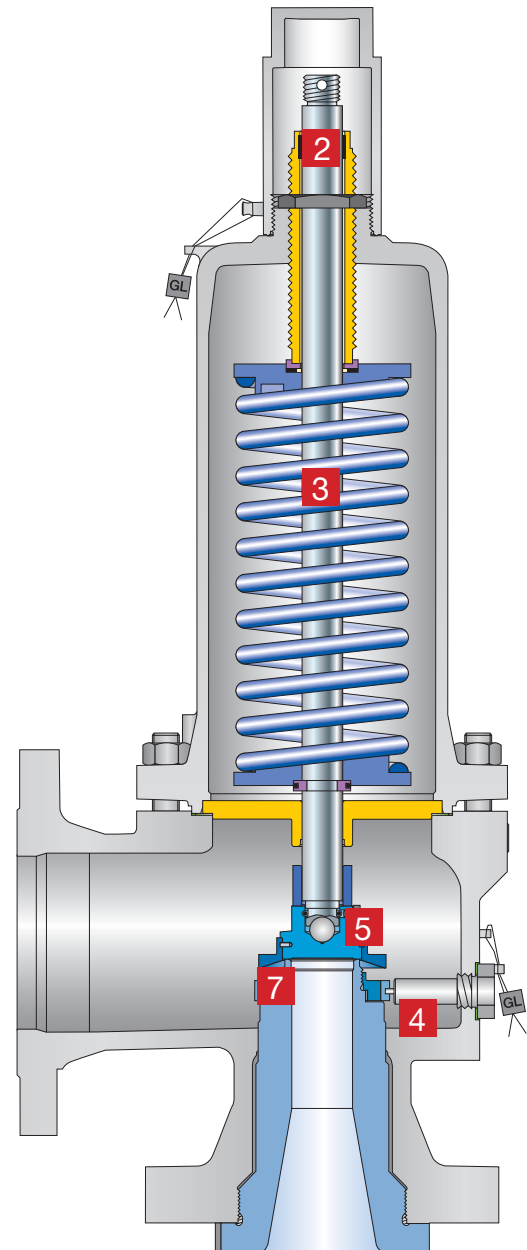
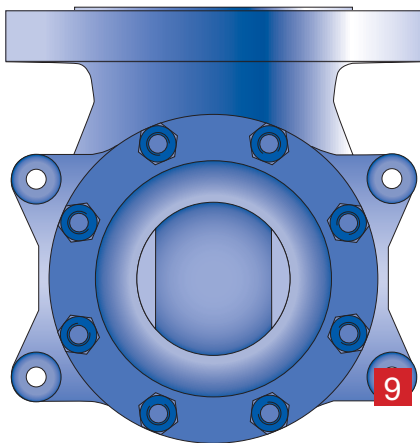

... a not so brief history of LESER

Headquartered in Germany, with a state of the art factory and more than 300 employees LESER are supplying high quality safety valves all over the world.



The company started in Germany in 1818, more than 185 years ago, as a brass foundry and developed a product portfolio of components of mechanical equipment and machines during the "industrial revolution".

In 1885 the company delivered its first safety valve and since the 1970's LESER has specialized only in safety valves.

Since the 1980's LESER have been the number one supplier for safety valves in Europe and strengthens this position each year. Currently LESER are expanding its activities worldwide.



Safe solutions from the specialist

Today, LESER's product range comprises a total of 7 product groups with 38 safety valve types. A variety of materials and sizes from DN 10 to DN 400 – 1/2" to 16", provide safe solutions for almost every industrial application.

High Performance:

Safety valves of this design are generally installed for protection of pressure vessels and industrial systems (gas, steam and liquids applications) to provide rapid discharge of the maximum possible mass flow.

API:

Safety valves according to the API Standard 526; predominantly applicable for the petrochemical and chemical industries.

Compact Performance:

Safety valves for protection of small and medium mass flows for classics like pumps and compressor, but also adapted for cryo applications.

Clean Service:

Safety valves for protection of systems with sanitary and hygienic requirements in the food, beverage and pharmaceutical industries.

Critical Service:

Safety valves semi or fully lined typically with PTFE, suitable for aggressive and corrosive media.

Modulate Action:

Safety valves which are installed for protection of small mass flow predominantly for liquids to assure a minimization of the media losses. Suitable for thermal relief applications.

Best Availability: Other complimentary product series such as supplementary loading systems, change-over valves and bursting discs which complete the LESER safety valve offering.

Why LESER?

Short delivery: Extensive stocks of LESER products are maintained in more than 20 countries to guarantee short delivery lead times worldwide. Most spares can be shipped on over night lead-time.

German manufacturing and assembly world-wide: LESER safety valves are manufactured exclusively in Germany by LESER! Certified and well-trained assembler network close to LESER's customer provides assembly and setting services with shortest response time. This guarantees a superior quality level worldwide.

New safety valve development: LESER continually improve existing valve lines and develop new valve models to fulfill customers' demands. The LESER R&D Team consists of over 30 people.

Proven technology: LESER operate three flow testing laboratories with ASME and TÜV certification, these are among the biggest facilities in the world. The simulation of customer plant configuration for safe solutions in special cases is daily business at LESER.

Special Solutions: LESER's extensive engineering capabilities combined with most modern in-house manufacturing equipment provides for quickest delivery of special solutions. We design, build and test according to your specification.

Installed base: By number LESER have the largest installed base of safety valves throughout the world. Currently LESER produce 75.000 safety valves per year. This installed base guarantees reliability for customers.

Focus on Safety Valves: LESER is a privately owned company that is totally focussed on design and manufacturing of one product: safety valves. That ensures LESER's commitment to your safety valve requirements.

All LESER Safety Valves carry CE and ASME

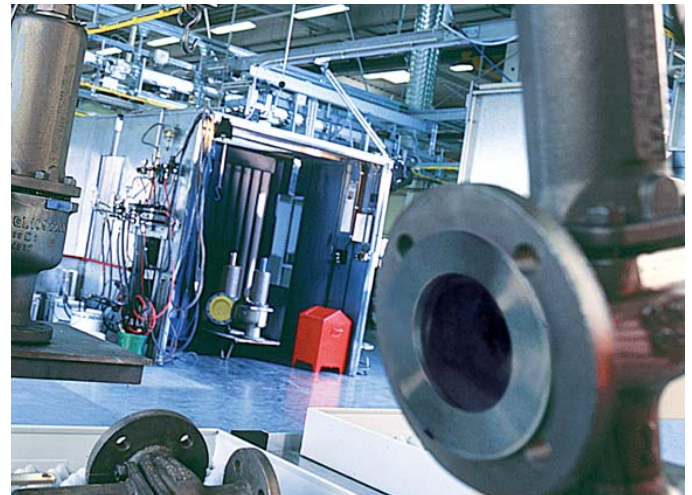

LESER information tools provide you with all product-related information you need:

- Applications
- Features and benefits
- How to orders
- Codes and standards
- Materials
- Dimensions and weights

- Pressure ranges
- Temperature ranges
- Options
- Spare parts
- Approvals
- Capacity tables

Simply state the number of required copies or get a pdf file.

Your request will be processed immediately.

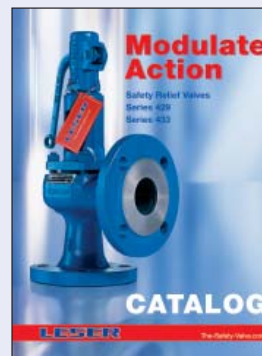
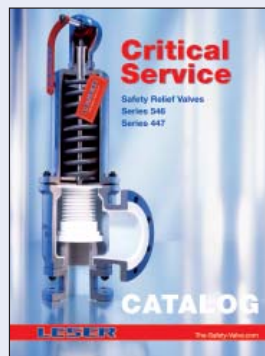
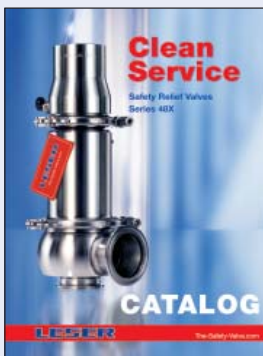
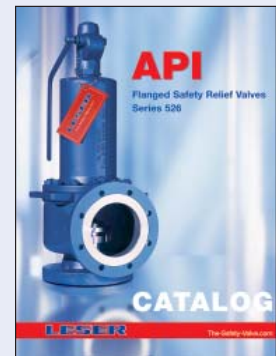
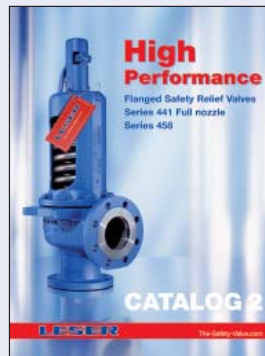

Order information:

Please send your request to your local representative or contact LESER GmbH & Co. KG:

Fax: +49 (40) 251 65-500

(Please use our **Fax Order** document)

E-Mail: sales@leser.com

Please send your request to our Sales Center

To: **LESER GmbH & Co. KG**

Fax: +49 (40) 251 65-500

Date: _____

From: _____

Catalog order:

High Performance [Catalog 1](#)

Flanged Safety Relief Valves

Series 441
Series XXL
Series 444

pdf

Printed version

No. of copies: _____

High Performance [Catalog 2](#)

Flanged Safety Relief Valves

Series 441 Full nozzle
Series 458

pdf

Printed version

No. of copies: _____

Compact Performance

Threaded Safety Relief Valves

Series 437
Series 459

pdf

Printed version

No. of copies: _____

API

Flanged Safety Relief Valves

Series 526

pdf

Printed version

No. of copies: _____

Clean Service

Safety Relief Valves

Series 48X

pdf

Printed version

No. of copies: _____

Critical Service

Safety Relief Valves

Series 447
Series 546

pdf

Printed version

No. of copies: _____

Modulate Action

Flanged Safety Relief Valves

Series 429
Series 433

pdf

Printed version

No. of copies: _____

S & R

Safety Relief Valves
for special or regional
applications

Series L & W
Series TRDF
Series TRDG
Series SBD
Type 612

pdf

Printed version

No. of copies: _____

CD order:

VALVESTAR®

- Ultimate sizing program
- Consideration of all relevant codes and standards
- Comprehensive documentation (sectional drawings, parts lists)
- Different language versions
- Help function

No. of copies: _____

Addressee

Please send the requested copies to:

Name: _____

Company: _____

Address: _____

E-Mail: _____

LESER

The-Safety-Valve.com

LESER GmbH & Co. KG

20537 Hamburg, Wendenstr. 133-135
20506 Hamburg, P.O. Box 26 16 51

Fon +49 (40) 251 65-100
Fax +49 (40) 251 65-500

E-Mail: sales@leser.com
www.leser.com